



هيئة تنظيم الاتصالات  
Telecommunications Regulatory Authority

**Development, implementation and use of bottom-up fixed and mobile  
network cost models in the Kingdom of Bahrain**

**Position Paper**

19 October 2011

Ref: MCD/10/11/144

Purpose: To identify and discuss the key features and principles to support the development, implementation and use of bottom-up cost models of fixed and mobile networks in Bahrain to determine the cost of supplying retail and wholesale telecommunications services.

## Position Paper

Development, implementation and use of fixed and mobile bottom-up network cost models

### Table of contents

Table of contents .....	2
List of acronyms used .....	4
1 Introduction.....	7
2 Rationale and purpose .....	9
2.1 Legal context .....	9
2.2 Economic background .....	10
2.3 Purpose of developing bottom-up cost models .....	11
3 Introduction to the different costing approaches .....	13
3.1 Which approach to cost modelling should be used? .....	13
3.2 How should assets be valued? .....	17
3.3 Which cost methodology should be used? .....	18
3.4 Which cost allocation approach should be used? .....	23
4 Methodological issues involved in bottom-up cost modelling .....	27
4.1 Technical issues .....	27
4.2 Financial issues .....	44
4.3 Charging basis.....	55
4.4 Use of gradients for the setting of regulated prices.....	55
4.5 Period of time covered by the model.....	58
5 Model overview .....	59
6 Operational issues.....	66
6.1 Identification of main steps .....	66
6.2 Data collection .....	67
6.3 Outline of the strategy to develop and validate the models .....	69
7 Use of models .....	71
7.1 Use of bottom-up models in Bahrain .....	71
7.2 Relevant factors to consider when using the models .....	71
7.3 Use of the models to set prices .....	75
8 Annex A – Cost allocation .....	79
8.1 Preliminary definitions .....	79
8.2 Proportional rules family of cost allocation method .....	81
8.3 Games-theory rules family of cost allocation method .....	85
8.4 Conclusion.....	87

## Position Paper

Development, implementation and use of fixed and mobile bottom-up network cost models

9	Annex B – Asset depreciation .....	90
10	Annex C –International regulatory approaches on methodological issues .....	115
10.1	Fixed core model .....	115
10.2	Mobile model .....	118
11	Annex D – European and Australian benchmark on costing approaches .....	121
11.1	Benchmark for local loop unbundling .....	121
11.2	Benchmark for mobile networks (termination rates).....	122
11.3	Benchmark for fixed core network (termination rates) .....	122
	References.....	124
	Annex A: List of questions included in the consultation document.....	126

## Position Paper

Development, implementation and use of fixed and mobile bottom-up network cost models

### List of acronyms used

ACCC	Australian Competition and Consumer Commission
AGCOM	Autorita per le Garanzie nelle Comunicazioni (Italian telecommunications regulator).
ARCEP	Autorité de Régulation des Communications Electroniques et de la Poste (French telecommunications regulator)
Batelco	Bahrain Telecommunications Company B.S.C
BD	Bahraini Dinar
BEREC	Body of European Regulators of Electronic Communications
BIPT	Institut Belge des Services Postaux et de Télécommunications (Belgian telecommunications regulator)
BU	Bottom-Up
CAPEX	Capital Expenditure
CAN	Customer Access Network
CAT	Customer Access Tail
CCA	Current Cost Accounting
ComReg	Commission for Communications Regulation (Irish telecommunications regulator)
D-LRIC	Distributed-LRIC
D-LRIC+	Generally referred to as LRIC+
DAC	Depreciated Actual Cost
DORC	Depreciated Optimised Replacement Cost
DSL	Digital Subscriber Line
DSLAM	Digital Subscriber Line Access Multiplexer
EC	European Commission
ECJ	European Court of Justice
EPMU	Equi-proportionate mark-up
ERG	European Regulators Group
ETNO	European Telecommunications Network Operator association
EU	European Union
FAC / FDC	Fully Allocated Cost / Fully Distributed Cost
FCM	Financial Capital Maintenance
FDD	Frequency-Division Duplexing
FTTB	Fibre to the building
FTTC/FTTSC	Fibre to the Curb / Fibre to the Street Cabinet
FTTH	Fibre to the Home
FTTx	Fibre to the x (Generic name for fibre access network architecture)
FL	Forward-looking
GCC countries	Gulf Cooperation Council countries
GPON	Gigabit Passive Optical Network
GSM	Global System for Mobile (2G)
GSMA	GSM Association
HCA	Historical Cost Accounting

## Position Paper

Development, implementation and use of fixed and mobile bottom-up network cost models

HLR	Home Location Register
ICT	Information and Communication Technology
IPLC	International Private Leased Circuit
ISDN	Integrated Services Digital Network
ITU	International Telecommunication Union
Kbps	Kilobits per second
LL	Leased Line
LLCO	Local Leased Circuit for OLO
LLU	Local Loop Unbundling
LRAIC / LRIC	Long Run Average Incremental Cost / Long Run Incremental Cost
LRIC+	LRIC plus mark-up for non-network common cost
LTE	Long Term Evolution
MB	Megabytes
Mbps	Megabits per second
MDF	Main Distribution Frame
MHz	MegaHertz
MPLS	Multiprotocol Label Switching
MSAN	Multi-Service Access Node
MSC	Mobile Switching Centre
MTR	Mobile Termination Rate
MVNO	Mobile Virtual Network Operator
NBN	National Broadband Network
NGA	Next Generation Access
NGN	Next Generation Network
NITA	National Information Technology Agency (Danish telecommunications regulator)
NPV	Net Present Value
NRA	National Regulatory Authority
OCM	Operating Capital Maintenance
Ofcom	Office of Communications (UK telecommunications regulator)
OLO	Other Licensed Operator
OPEX	Operating Expenditure
P2P	Point-to-point
PSTN	Public Switched Telephone Network
PTS	Post and Telestyrelsen (Swedish telecommunications regulator)
RO	Reference Offer
RNC	Radio Network Controller
SDH	Synchronous Digital Hierarchy
SLU	Sub Loop Unbundling
SMP	Significant Market Power
TD	Top-Down
TDD	Time-Division Duplexing
TRA	Telecommunications Regulatory Authority of the Kingdom of Bahrain
UMTS	Universal Mobile Telecommunications System (3G)

## Position Paper

Development, implementation and use of fixed and mobile bottom-up network cost models

Viva	STC-Bahrain
VoD	Video-on-Demand
WACC	Weighted Average Cost of Capital
Zain	MTC-Vodafone Bahrain B.S.C.

## Position Paper

Development, implementation and use of fixed and mobile bottom-up network cost models

### 1 Introduction

1. The purpose of this Position Paper issued by the Authority is to identify and discuss the key features and principles to support the development, implementation and use of bottom-up cost models of fixed and mobile networks in Bahrain. In contrast to top-down models which are based on accounting systems, bottom-up cost models are engineering models which use detailed data and engineering rules to (re)build a hypothetical efficient network. The Authority intends to develop and use bottom-up cost models to complement existing regulatory instruments in determining the cost of retail and wholesale telecommunications services in Bahrain as well as to gain a better understanding of the cost structure and drivers of telecommunications networks.
2. The Position Paper sets out the Authority's views on a number of issues relating to the development, implementation, and use of bottom-up cost models. The Authority intends to develop three bottom-up models in accordance with this Position Paper, having due regard to the submissions received from interested parties. The resulting cost models, one for mobile networks, one for fixed access networks and one for fixed core networks, will be used by the Authority, in conjunction with existing regulatory instruments, when exercising its regulatory functions under Legislative Decree No.48 of 2002 promulgating the Telecommunications Law ("Telecommunications Law").
3. As discussed later, the Authority considers that the development of robust bottom-up cost models is an important and valuable exercise, both for the regulator and the industry. From the regulator's perspective, the use of bottom-up models allows for greater transparency of the factors that drive the costs of providing telecommunications services, allowing a better understanding of costs as well as the ability to test the sensitivity of costs to key variables. For example, by allowing the network to be re-dimensioned, bottom-up cost models can more accurately estimate costs under different demand scenarios. In this regard, such models can also be a useful tool for operators in the context of, *inter alia*, considering new investments (such as new fibre deployments) or achieving cost efficiencies. Bottom-up cost models are an essential complement to existing regulatory instruments.
4. The Authority does not intend to supplant the use of existing 'top-down' cost information with the bottom-up cost models, but instead use both modelling approaches as complementary regulatory tools. By examining costs from both a top-down and a bottom-up perspective, the Authority will be better placed to determine tariffs for telecommunications services that are more closely aligned with the criteria established in the legislation.
5. A draft version of the present document was initially published for consultation on 19 May 2011. At the end of the 2-month consultation period, the Authority had received submissions from four operators, namely Batelco Telecommunications Company B.S.C. ('Batelco'), Lightspeed Communications W.L.L. ('Lightspeed'), MTC-Vodafone Bahrain B.S.C. ('Zain') and STC-Bahrain ('Viva'). This document is the final version and takes into account the comments and issues raised by the four respondents.
6. In the following section, the Position Paper sets out the context for undertaking a bottom-up cost modelling exercise. This includes a summary of the legal framework within which the Authority operates, and a discussion of the economic rationale for ensuring that the

## **Position Paper**

Development, implementation and use of fixed and mobile bottom-up network cost models

tariffs for key telecommunications services reflect an appropriate measure of the cost of supplying those services. Having provided this background, the Authority then explains why bottom-up cost models are being developed, in particular given the use of existing top-down models to determine telecommunications tariffs in Bahrain.

7. In Section 3, the Position Paper introduces the different costing approaches that can be taken, including the relative merits of the top-down and bottom-up modelling approaches, the valuation of assets, and an overview of the relevant cost methodologies that could potentially be considered.
8. Section 4 of the Position Paper discusses important methodological issues for bottom-up cost modelling. These include technical and financial issues. A number of these relate to the structure of the cost model, such as the degree of optimisation undertaken by the model ('scorched node' or 'scorched earth') and the type of optimisation approach considered for network dimensioning ('yearly optimisation' or 'historic' optimisation), while for other issues, the modelling is likely to be flexible enough to accommodate a number of options.
9. In Section 5, the Authority provides an overview of the structure and format of the bottom-up cost models that it intends to develop, including the main technical, economic, and financial steps that are needed to build each of the cost models.
10. Section 6 covers operational issues relating to the development of bottom-up cost models, including the key steps in model development, and the involvement of industry operators in particular in relation to the provision of information and the validation of the cost models.
11. Finally, Section 7 relates to the use of the bottom-up cost models in the context of the regulatory framework that exists in Bahrain. This includes examples of the way in which the bottom-up model is likely to be used, and how the results of the cost model may be operationalised when setting tariffs.
12. Annexes A and B provide further information respectively on cost allocation methods and asset depreciation methods while Annexes C and D contain international benchmarks showing which approaches national regulatory authorities ("NRAs") have followed in developing cost models.

### **Legal status of the Position Paper**

13. This Position Paper is issued by the Authority pursuant to its powers and duties granted to it under Article 3 of the Telecommunications Law.
14. The Authority has decided in this instance to issue a non-binding Position Paper on the principles to be used in the development, implementation, and use of bottom-up network cost models. Should the Authority significantly depart from the Position Paper then the Authority will provide an explanation for doing so.

## Position Paper

Development, implementation and use of fixed and mobile bottom-up network cost models

## 2 Rationale and purpose

### 2.1 Legal context

15. As provided for in Article 3 of the Telecommunications Law, the Authority has the duty to promote effective and fair competition between new and existing operators and to protect the interests of users with respect to pricing, availability, and quality of services offered.
16. The legal framework for the setting of interconnection and access tariffs is set out in Article 57 of the Telecommunications Law. According to Article 57(b), the Authority may set terms and conditions and tariffs for interconnection and access services<sup>1</sup> supplied by a dominant operator, and

*“such terms and conditions and tariffs shall be fair, reasonable and non-discriminatory and **the tariffs shall be based on forward-looking incremental costs** or by benchmarking such tariffs against tariffs in comparable Telecommunications markets.”*

*[emphasis added]*
17. Article 58 of the Telecommunications Law provides for tariffs charged by licensed operators to be *“fair and equitable, non-discriminatory and based on forward-looking costs”*.
18. To assess whether tariffs meet those tests, the Authority has issued a number of instruments such as:
  - a. The Accounting Separation Regulation (issued on 2 August 2004) that requires licensed operators to prepare both FAC and LRAIC accounts on an annual basis;
  - b. Reference Offer Orders (e.g. orders dated 25 January 2011, 24 May 2009, 17 July 2007, 23 May 2007, 6 August 2006, 12 July 2006);
  - c. 2010 Statement on the regulation of mobile termination services (issued on 1 February 2010); and
  - d. The Retail Tariff Notification Regulation (issued on 21 February 2010).
19. As discussed throughout this Position Paper, the Authority considers that bottom-up cost models represent an important additional tool that will complement the above regulatory instruments and will enable the Authority to undertake its duties under the Telecommunications Law in a more effective and transparent manner. Bottom-up models are tools that assist regulators in setting prices based on forward-looking incremental costs. Starting from Q3 2011, the Authority will develop and implement bottom-up cost models for fixed core, fixed access and mobile networks in the Kingdom of Bahrain. The bottom-up cost models will be used among other tools to set the terms for regulated services. They may also be used in other contexts where costing information is necessary, such as investigations for anti-competitive behaviour.

---

<sup>1</sup> While Article 57(b) refers to interconnection services, Article 57(e) states that the Authority may determine tariffs and terms and conditions for access services according to the provisions of Article 57(b).

## Position Paper

### Development, implementation and use of fixed and mobile bottom-up network cost models

20. The development of bottom-up cost models is fully consistent with the Authority's duties to promote competition and protect the interest of end-users. The models will assist the Authority in ensuring that regulated charges are based on forward-looking incremental cost. Regulated charges should reflect the efficient cost of providing the services so that wholesale and retail consumers face charges consistent with cost. Inefficiencies which are passed on to users lead to lower welfare. This is because if inefficiencies were recovered from purchasers of the services, operators would have muted incentive to be more efficient and reduce costs. Consumers would not be protected (as they would face higher than justified prices) and the development of competition would be hindered. In that context, the development of bottom-up models is critical since it will enable the setting of regulated charges based on efficient costs and hence consistent with Articles 57 and 58 of the Telecommunications Law.

## 2.2 Economic background

21. Historically, the provision of certain telecommunications services has been considered to possess natural monopoly characteristics (and was in many instances a legal monopoly). In economic theory, monopolies are usually associated with economic inefficiencies.<sup>2</sup> Such inefficiencies result from a profit-maximising monopolist restricting output below the competitive level in order to increase prices above the competitive level.<sup>3</sup> As consumers are forced to pay a price that exceeds the cost of producing an additional unit of the service, monopoly pricing leads to a reduction in the level of 'allocative efficiency'. In addition, monopolists are said to face poor incentives to increase 'productive efficiency' as there is little or no competitive pressure to minimise costs and be efficient. Similarly, the lack of competitive pressure can mean that a monopolist has reduced incentives to develop innovative products or services, leading to lower levels of dynamic efficiency compared to more competitive markets.
22. This is why, from an economic point of view, natural (or legal) monopolies require regulation to contain their market power in order to reduce inefficiencies and maximise social welfare. To achieve this goal, NRAs typically seek to introduce cost-based pricing as a regulatory remedy in circumstances where market power concerns have been identified. This is the approach that has been taken in Bahrain, where as noted above, the Authority is required under Article 57 of the Telecommunications Law to set tariffs for interconnection and access services supplied by operators with market power, with such tariffs being based on forward-looking incremental costs.
23. Under such pricing, the dominant or SMP operator is able to recover the efficient costs of providing the service (including an appropriate return *on* capital and return *of* capital<sup>4</sup>), preserving that operator's incentives to maintain and invest in its network. Such pricing

---

<sup>2</sup> There are three general forms of economic efficiency. **Allocative efficiency** refers to the optimal allocation of resources to meet consumer demand, and is achieved where price is set equal to marginal cost. **Productive efficiency** refers to producing goods and services at minimum cost. **Dynamic efficiency** refers to changes in efficiency over time, and is generally regarded as being promoted where producers have incentives to invest and innovate to meet future consumer demand.

<sup>3</sup> Specifically, the monopolist will maximise profits by producing the level of output at which its marginal cost is equal to its marginal revenue.

<sup>4</sup> The return *on* capital is provided through the cost of capital (i.e. the WACC), and the return *of* capital is provided through an allowance for depreciation.

## Position Paper

### Development, implementation and use of fixed and mobile bottom-up network cost models

also encourages greater competition and efficiencies in the relevant downstream markets. In contrast to the outcomes in a market characterised by SMP or dominance, cost-based pricing provides efficient pricing signals to the market and leads to an efficient allocation of resources as buyers only pay for the costs that are associated with meeting their demand. Excessive profits and monopoly rents are not passed on to consumers and hence do not distort consumption decisions. Cost-based prices are consistent with what can be expected in a competitive market.

24. The correct measure of costs will depend on the type of services under consideration. Where services are supplied in a perfectly competitive market, prices will be set at a level that reflects the marginal cost of producing the service. However, in markets such as telecommunications, where there are economies of scale and scope, the appropriate pricing principle must allow for the recovery of relevant fixed and common costs. In most jurisdictions, the regulatory framework applying to telecommunications defines access pricing principles that are based on some measure of incremental cost, where, depending on the definition of the increment of service, fixed costs are taken into account. As noted above, the legislative framework that applies in Bahrain specifically refers to forward-looking incremental costs.
25. The Position Paper further discusses the concept of cost in the following sections. However, the Authority re-iterates that the determination of cost-based interconnection and access tariffs is critically important in the context of telecommunications markets, which are characterised by natural monopoly 'bottlenecks' within a vertically-integrated market structure. A wide range of telecommunications services are supplied across a number of functional dimensions, with the upstream bottleneck input (such as the local loop) being used to supply a downstream service in a competitive or potentially competitive market (such as fixed broadband services). However, if the vertically-integrated operator is able to sell the upstream input at a price that is inflated above the relevant measure of the input cost, a barrier to efficient entry and expansion in the downstream market is created, as the entrant will face a higher cost (in the form of the inflated wholesale tariff) than does the incumbent and/or the incumbent will enjoy unreasonable profits for this input. This may give rise to distortions of competition at the downstream level (e.g. margin squeeze) and at the upstream level (e.g. inefficient investment signals). By ensuring that the access price is set at cost, the Authority is promoting effective competition in the downstream market, ensuring that the vertically-integrated operator is not enjoying unreasonable profits, and providing adequate investment signals.

### 2.3 Purpose of developing bottom-up cost models

26. The current framework for setting terms and conditions and tariffs for wholesale interconnection and access services in Bahrain is based around the submission of Reference Offers (ROs) to the Authority, who then assesses whether the tariffs and other terms and conditions proposed in the Reference Offers are fair, reasonable and non-discriminatory. In accordance with Article 57 of the Telecommunications Law, when the Authority considers that the proposed tariffs, and other terms and conditions are not fair, not reasonable and discriminatory, then the Authority may issue an Order in which it determines the tariffs as it considers appropriate in accordance with Article 57.
27. To date, the ROs that have been submitted to the Authority, and the Authority's evaluation of those offers, have typically been based on a top-down accounting framework in which

## Position Paper

### Development, implementation and use of fixed and mobile bottom-up network cost models

the cost accounting data of the operator under consideration is used. Top-down models reflect existing networks, which may or may not represent efficient network operations. In addition, top-down models are typically inflexible and lack transparency, and can rely on data that may be out-of-date. For instance, in the last two years there has been a period of about 14 months between the time when costs are incurred by Batelco and the time when regulatory accounts are ready. The subsequent time it takes for Batelco to prepare its RO submission and for the Authority to review it, means that approved or ordered charges are based on costs which have been incurred a considerable time before (e.g. about 2 years for the RO price issued on 25 January 2011 which is based on 2008 costs).

28. In contrast, the development and use of bottom-up cost models more closely reflects the economic costs (as opposed to accounting costs) of efficient telecommunications networks and assists regulatory authorities in setting prices based on forward looking incremental costs in line with the requirements of the Telecommunications Law. Such models provide greater transparency and thus reduce the information asymmetry between operators and the regulator. Enhanced visibility of the structure and operation of the bottom-up models also allows for sensitivity and scenario analyses to be undertaken, for example to examine how costs differ as penetration levels differ or as the cost of capital changes. Reliance on the output of top-down models can be problematic as they reflect accounting costs which may vary significantly year on year due to accounting reasons. This contrasts with economic costs which are not subject to this kind of undesirable variability.
29. The Authority believes that the existing top-down accounting framework that has been developed and used to set wholesale tariffs, review retail tariffs and assist in competition investigations to date in Bahrain remains a very useful regulatory tool and source of information for regulatory purposes. The Authority is not proposing to supplant the use of existing top-down cost information with the bottom-up cost models, but instead use both modelling approaches as complementary regulatory tools. By examining costs from both a top-down and a bottom-up perspective, the Authority will be better placed to determine tariffs for telecommunications services that are more closely aligned with the criteria established in the legislation.
30. Achieving cost-oriented pricing requires regulators to have detailed information concerning the operator's costs and, more generally, a sound understanding of the business of operators. Cost models are not only a tool to assess and set tariffs such as wholesale access and interconnection tariffs but can be used in a variety of regulatory and commercial contexts such as evaluating the impact of proposed regulatory measures or policies on costs and penetration rates, estimating network deployment CAPEX and OPEX for business planning purposes, and assessing the expected profitability of network deployment by geographical areas and by segments, etc. In a nutshell, a regulatory cost model can provide tangible benefits both for operators and regulators as it brings forward an objective, transparent, and holistic regulatory tool – built in a cooperative way and through a consultative process.

### 3 Introduction to the different costing approaches

31. NRAs as well as operators have a broad choice regarding the tools they may use for calculating cost. As the Authority wishes to broaden the range of tools at its disposal to ensure that regulated prices are fair and reasonable and non-discriminatory, it has decided to develop a bottom-up cost model for fixed core, fixed access and mobile networks in Bahrain.
32. Whatever the methodology selected, developing a cost model invariably aims at calculating the unit cost of a service<sup>5</sup> under a given set of assumptions. The supply of a defined increment of service will typically involve specific assets and expenditures. Therefore it is possible to summarise the process of calculating the unit cost of a service with the following general formula:

$$\text{Service unit cost} = \frac{\text{Depreciation charge} + \text{Return on capital employed} + \text{Opex}}{\text{Number of units of service produced}}$$

33. Before presenting and discussing the main cost modelling issues, this section outlines four high-level questions that are relevant to the development of cost models for telecommunications networks:
- (§ 3.1) Which approach to cost modelling should be used?
  - (§ 3.2) How should assets be valued?
  - (§ 3.3) Which cost methodology should be used?
  - (§ 3.4) Which cost allocation approach should be used?

#### 3.1 Which approach to cost modelling should be used?

34. There are two main approaches to cost modelling:
- Top-down; and
  - Bottom-up.
35. To date, the Authority has relied on top-down accounting models to determine appropriate tariffs for regulated services in Bahrain. In this section, the Authority sets out the relative merits of top-down and bottom-up cost models. These factors have been important in the Authority's decision to develop a set of bottom-up cost models to complement the existing top-down modelling approach and to strengthen the regulatory framework in Bahrain.
36. Under a top-down approach, cost inputs are taken from the operator's accounting records and are allocated to services by using service demand and allocation rules. This method does not involve detailed network modelling. Instead, the relationships between the production of services (outputs) and costs are derived from historical observations. Costs can however be projected forward on the basis of output and cost forecasts.

---

<sup>5</sup> A service can be defined as a bundle of sub-services.

## Position Paper

### Development, implementation and use of fixed and mobile bottom-up network cost models

37. Under a bottom-up approach, the model uses detailed data and engineering rules to (re)build a hypothetical efficient network, reflecting as appropriate the network of the modelled operator. The network is modelled so as to deliver telecommunications services and to satisfy the demand for these services. The costs of this network (including capital costs, operations and maintenance costs) are then allocated to all the services provided over that network. This approach has more of an 'engineering-based' nature than the top-down approach (which is more 'accounting-based') as it starts by dimensioning and building a network and identifies all components of cost at a much more granular level.
38. At a high-level principle, bottom-up modelling is performed in three steps:<sup>6</sup>
- a. In the first step, the services to be modelled are identified (interconnection services, local access services, etc.) and data relating to the demand for these services is gathered (the number and location of customers, annual traffic and traffic during peak hours if relevant, etc.);
  - b. In the second step, the model designs an efficient network<sup>7</sup> by establishing which assets (equipment, facilities, links, etc.) are required in order to provide in the most cost-effective manner the services demanded. At this stage, the model is effectively determining the efficient *type* and *quantity* of assets required to satisfy demand;
  - c. Thirdly, once the network has been designed and dimensioned, each asset is valued and depreciated (with a "historical" or "current" approach<sup>8</sup>) and a unit cost of usage can be derived through allocation keys and routing tables.
39. The key step of the bottom-up approach compared to the top-down approach is the second step where engineering rules and cost allocation drivers are used to build an efficient network to meet demand, and from which costs can then be derived for each service being modelled.
40. The relative advantages and disadvantages of both approaches are summarised in the following table.

---

<sup>6</sup> In section 0, a more precise description of steps involved in the building of a bottom-up cost model is provided.

<sup>7</sup> Efficiency can be introduced through specifying optimization rules which define the extent to which a new network (or part of a network) is built without regard to (or unconstrained by) historic decisions.

<sup>8</sup> See section 3.2.

## Position Paper

### Development, implementation and use of fixed and mobile bottom-up network cost models

**Table 1: Pros and cons of Top-Down and Bottom-Up approaches**

	Pros	Cons
<b>Bottom-up</b>	Model costs that an efficient entrant would face – send appropriate “build or buy” signals	May over-optimise or omit costs. If this happens, the operator will be under-compensated and incentives to invest in the network will thus be reduced
	Flexible — can change assumptions readily	Modelling of operating expenditure can be difficult
	Transparent — much of the information used is publicly available	Data needed for the model may not exist
	Adequate for prospective analysis (forward looking view of cost evolution)	The modelling process can be time-consuming and expensive
<b>Top-down</b>	Incorporate actual costs	Include the firm's actual costs, and so are likely to incorporate inefficiencies
	Useful for testing results from bottom-up model	Less transparent, including confidentiality issues which mean that other stakeholders may not have access to the information used
	May be faster and less costly to implement, but this depends on how well categories in the financial accounts match the data required	The parties may dispute the cost allocation rules used (the rules used to allocate shared and common costs among specific services)
		Data may not exist in the required form

Source: Based on ICT Regulation toolkit, chapter “3.3.2 Long-Run Incremental Cost Modelling”

41. Each of the top-down and bottom-up approaches has distinct benefits and drawbacks:
- a. The top-down approach tends to reflect, by construction, the actual costs incurred by the operator and provides a snapshot of the reality. It reflects the existing configuration of networks, which may or may not reflect efficient network operations. Because it reflects only the current situation (which in turn will be a legacy of historical decisions), the top-down approach has difficulties in establishing robust forecasts. It also lacks transparency. Furthermore, any existing inefficiencies are embedded in the cost estimates. As the ITU states in its ICT Regulation Toolkit, it is more complex to deal with inefficiencies in a top-down model than in a bottom-up model:<sup>9</sup>

*“It is possible to make adjustments to top-down approaches to remove inefficiencies in the firm’s current network configuration and costs, but it is difficult to do so transparently. The incumbent firm will have more information about its historic performance and its accounts than the regulator or new entrants.”*
  - b. A bottom-up approach provides a better understanding of underlying cost structures and cost drivers. Bottom-up cost models are more transparent and better able to analyse and determine accurately changes in cost over time under significant uncertainty or where cost structures are expected to change. It is more

<sup>9</sup> ITU, ICT Regulation Toolkit (<http://www.ictregulationtoolkit.org/en/section.2092.html>).

## Position Paper

### Development, implementation and use of fixed and mobile bottom-up network cost models

flexible with respect to a wide range of parameters, such as legacy issues (the distinction between a “scorched-earth” and a “scorched-node” approach is detailed in section 4.1), engineering rules and operating costs. Compared to top-down models, bottom-up models are more amenable to sensitivity analysis. A bottom-up model is also able to model expected costs of a network that is currently being built (such as for example an FTTH network), whereas a top-down model is not capable of doing so. Dealing with efficiencies is also easier than with a top-down approach, as costs are derived from service demand through established engineering rules.<sup>10</sup> This approach has greater transparency than a top-down approach, as the inputs, engineering rules and assumptions used in a bottom-up engineering model are all visible and can be more objectively tested. Transparency and visibility are important to help address the information disadvantage that the regulator has compared to the incumbent and regulated firms. Transparency also helps operators and regulators have a stronger basis and a better understanding of regulatory decisions. A key advantage of bottom-up models is that, by being able to calculate the costs of a “new” network, they can provide appropriate ‘build or buy’ signals. This is important to promote efficient investment and achieve the right balance of infrastructure-based and service-based competition. The main drawback of the bottom-up approach is that estimated costs are not necessarily in line with existing operators’ costs and may not reflect achievable levels of efficiency.<sup>11</sup>

42. It is possible to combine the strengths of both of these approaches. A bottom-up model is first developed and calibrated considering top-down information among other sources of information. A sensitivity analysis can then be performed by adjusting the unit cost levels and cost causality relationships of each cost component, so that the drivers of the differences between the output of each approach can be identified and taken into account in decision making as appropriate.
43. A top-down model can usefully complement the bottom-up model to have a better understanding of the cost structure of the modelled operator and as a point of comparison. However, any comparison should not result in the inclusion of inefficiencies in the cost estimates. This has been recently highlighted by the European Commission in the specific case of termination rate calculation.<sup>12</sup>

---

<sup>10</sup> The European Commission has recently recognised the benefits of Bottom-up cost models in its Commission staff working document accompanying the Commission Recommendation on the regulatory treatment of fixed and mobile termination rates in the EU, Explanatory Note, C(2009) 3359 final, SEC(2009) 599, May 2009. “*BU models use demand data as a starting point and determine an efficient network capable of serving that demand by using economic, engineering and accounting principles. BU models give more flexibility regarding network efficiency considerations and reduce the dependence on the regulated operator for data. A BU model is synonymous with the theoretical concept of developing the network of an efficient operator because it reflects the equipment quantity needed rather than actually provided and the model ignores legacy costs. (...) Although BU models are generally developed by NRAs, operators can contribute to the model inputs and assumptions. This will increase the transparency and objectivity of BU models, although it carries the risk that ‘negotiated’ figures, as opposed to more accurate figures, will be used in the model.*” (page 13).

<sup>11</sup> As discussed elsewhere in this paper, it is for this reason (i.e. the potential omission of costs or overstatement of efficiencies) that the Authority considers it critical for operators to be involved in the development and validation of the bottom-up cost models.

<sup>12</sup> European Commission, Commission staff working document accompanying the Commission Recommendation on the regulatory treatment of fixed and mobile termination rates in the EU, Explanatory Note, C(2009) 3359 final, SEC(2009) 599, May 2009, pages 13-14.

## Position Paper

### Development, implementation and use of fixed and mobile bottom-up network cost models

*“Given the fact that a bottom-up model is based largely on derived data, e.g. network costs are computed using information from equipment vendors, regulators may wish to reconcile the results of a BU model with the results of a TD model in order to produce as robust results as possible and to avoid large discrepancies in operating cost, capital cost and cost allocation between a hypothetical and a real operator. The purpose of the reconciliation is to show and to quantify the sources of differences between both models and to make appropriate adjustments accordingly, thus assisting in the verification of the BU model. This may be appropriate, for example, where there is an information asymmetry or a risk of certain cost categories being erroneously omitted. However, any modification of the BU model must take into account the necessity of showing the costs of an efficient operator; it should not be done merely to bring the results of both models closer.”*

44. Bottom-up and top-down approaches are thus complementary. Whereas top-down models are typically built by regulated firms, regulators generally developed bottom-up models in participation with the industry. While a top-down approach is useful in order to provide a snapshot of the aggregated cost incurred by an operator (and also of its profits), it is not fully flexible and transparent. A bottom-up approach on the other hand offers a clearer understanding of cost drivers, is flexible in the case of structural changes, has a more objective treatment of efficiency, and offers greater transparency. In addition, bottom-up models are more suitable for forward-looking analysis, and avoid regulatory lags associated with top-down data that can often be out-of-date. Overall, bottom-up models are an essential tool to support robust and evidenced-based regulation.

### 3.2 How should assets be valued?

45. There are two broad approaches to asset valuation:
- a. Historical costs; and
  - b. Current costs.
46. A historical cost approach consists of taking the costs of the modelled network as equal to the operator’s accounting costs. A historical cost approach is relatively easy to implement, especially if the operator has a thorough and well maintained analytical accounting system. However, a historical cost approach may not be suitable for regulatory purposes as the aim of regulatory decision is, among other objectives, to define what should be the economic conditions of an effectively competitive market. In particular, historical costs are not able to reflect, by definition, changes in asset prices over time, unless the network has been recently deployed. As a result, the valuation of assets on the basis of their historical cost will not provide good “build or buy” signals for service- or infrastructure-based entry decisions when asset prices change over time.
47. This is why a ‘current cost’ approach is generally preferred for network modelling purposes. A current-cost approach implies that whatever the source taken for the costs, the model ensures that it should reflect the current and expected value of the assets. To recognise the effect of changing asset prices, the current cost approach requires revaluing assets to reflect the current price of assets.

## Position Paper

Development, implementation and use of fixed and mobile bottom-up network cost models

48. The difference between historical and current asset valuations is that the latter reflect asset price changes through the evolution of the depreciation charges calculated.<sup>13</sup> This enables the cost modelled to better reflect the cost base of a competitive market.
49. However, for those parts of a telecommunications network where “build or buy” decisions are less relevant, such as the fixed access network which is typically regarded as a natural monopoly, the use of historic costs may be appropriate. This has been explicitly recognised in a number of regulatory decisions in other jurisdictions in recent years. For example, in Australia the Australian Competition and Consumer Commission (ACCC) has recently reviewed the access pricing principles for fixed-line access services,<sup>14</sup> and has in particular proposed a move away from valuing the access network on the basis of its current replacement cost. In doing so, the ACCC noted the limitations of using a replacement cost approach when pricing fixed network legacy services:<sup>15</sup>

“While the underlying rationale for the use of replacement cost approaches – that is, to promote efficient ‘build/buy’ decisions – remains valid, its continued application may be questioned in the current telecommunications environment.

In particular, it has become apparent that Telstra’s copper CAN displays enduring bottleneck characteristics, rather than being a network likely to be bypassed through technological or market development. It is also unlikely that competitors will build alternate CAN infrastructure. The ACCC therefore considers that a replacement cost pricing approach, with its rationale of providing efficient ‘build/buy’ signals, is less applicable in the present environment.”

50. This proposed approach was supported by the regulatory appeals body in Australia, the Australian Competition Tribunal.<sup>16</sup>
51. The Authority will implement the ‘current cost’ approach in the bottom-up models. However, the Authority intends to compare current price valuation with historic valuation during a bottom-up top-down ‘comparison’ phase. When deemed necessary, the Authority will proceed to adjustments.

**Key message 1:** The Authority will implement the ‘current cost’ approach in the bottom-up models.

### 3.3 Which cost methodology should be used?

52. There are two main cost methodologies used by NRAs:
- the Fully-Allocated Cost (FAC) methodology; and
  - the Long-Run Incremental Cost (LRIC) methodology.

---

<sup>13</sup> see Annex B – Asset depreciation.

<sup>14</sup> ACCC, “Review of the 1997 telecommunications access pricing principles for fixed line services: Draft report”, September 2010.

<sup>15</sup> *ibid*, pages 25-26.

<sup>16</sup> *ibid*, page 16.

## Position Paper

Development, implementation and use of fixed and mobile bottom-up network cost models

53. Though some methodological aspects encountered in FAC are similar in LRIC, the main difference between the two methodologies is that the FAC approach is based on accounting practices whereas LRIC is based on economic reasoning.
54. As an accounting approach, the FAC methodology is based on the expenses incurred by the operator and allocates them to each service in accordance with the cost causation principle. Under that methodology, a cost breakdown procedure is used that groups together costs by nature and function to calculate the cost of each service. This approach implies that reliable accounting information is available, which is usually generated by activity-based accounting systems.
55. The LRIC methodology is more grounded in economics. As discussed earlier, in a perfectly competitive market, prices are set equal to marginal costs. Under certain strong assumptions, marginal cost pricing maximises social welfare and results in an efficient resource allocation and efficient market entry. However, in the presence of economies of scale and economies of scope (arising from fixed and common costs respectively), marginal cost pricing will lead to under-recovery of costs. A way to deal with this problem is to measure marginal cost in the long run, taking account of service-specific fixed costs. Another way to deal with it is to define larger increments in order to account for the cost effects of joint production and economies of scope and scale. This led to the development of the LRIC methodology, which considers that the cost of a service is equal to the change in total cost resulting from a discrete variation in output in the long run (that is when all inputs are variable).<sup>17</sup>
56. The LRIC methodology allows for more flexibility than FAC as the notion of “increment” can take several forms. A single service or group of services could be defined as the increment, but also the entire portfolio (where a long run average incremental cost is calculated) or at the other end a single unit of production (where a marginal cost is calculated). The LRIC methodology can thus produce different cost estimates for a given service, depending on the definition of the increment.
57. The prevalence of joint or shared assets in a telecommunications network<sup>18</sup> requires that when assessing the costs of a given service, an approach must be defined that will allocate the common costs incurred by the operator to the various services using the common assets. In telecommunications, the following cost categories can be identified:
  - a. **Directly attributable costs (also called increment specific costs):** these are costs that are incurred when producing a given service and that would cease to exist in case production of this service was stopped. In mobile networks, for example, the SMS server cost is a cost specific to the SMS service. Directly attributable costs can be fixed or variable (i.e. vary together with the level of output).
  - b. **Joint costs:** these are costs that are incurred by a set of services. In mobile networks, for example, the Home Location Register (HLR) is used both for on-net

---

<sup>17</sup> Economists distinguish between a “long run” and a “short run” period on the basis of a firm’s ability to unwind its fixed costs. In the short run, certain costs will be fixed in the sense that these costs could not be avoided even if the firm was to cease production. In contrast, the long run is the period of time where all costs (including costs that are fixed in the short run) can be treated as variable costs.

<sup>18</sup> In a telecommunications network, assets are usually not used to deliver a single service but are shared between a group of services or even among the entire portfolio of services produced by the operator. For example, a mobile base station can deliver SMS, voice, and data services.

## Position Paper

### Development, implementation and use of fixed and mobile bottom-up network cost models

calls and for mobile termination and is therefore a joint cost to both the on-net voice service and the mobile voice termination service.

- c. **Network common costs:** these are network costs used by all services. This is the case for backhaul in mobile networks or for trenches in fixed networks.
  - d. **Un-attributable costs (also called corporate overheads or non-network common costs):** these are costs that cannot be attributed in a non-arbitrary way (non-attributable costs), such as the costs associated with the Chief Executive, or the costs of operating a car fleet.
  - e. **Disallowed costs.** Costs which are excluded from the calculation of regulated services charges (e.g. fines for breaches of the Telecommunications Law).
58. There are a number of different measures of LRIC which could be used, with the key difference being the definition of the increment. The LRIC approach can be defined as the long-run cost of serving a defined 'increment' of demand. It is calculated as the difference between the total long-run cost of a network providing all services and the long-run cost of a network providing all services with the exception of the 'increment'. The resulting cost estimate will therefore depend on the size of the service increment. For example, at one extreme, where an increment is a single unit (i.e. a minute of voice traffic), the LRIC of supplying that unit will be equal to the marginal cost, which in the context of capital-intensive industries such as telecommunications, will generally result in a very low to null cost where there is spare capacity.<sup>19</sup> If however the increment is defined as the entire volume of voice traffic carried on a network, a wider set of costs will be captured, including fixed network costs.
59. Two main LRIC approaches are generally considered, with the two approaches differing according to their treatment of joint and common costs.
60. The traditional '**LRIC**' (**Total Service LRIC** ('**TSLRIC**')) approach operates with a broad increment.<sup>20</sup> The 'increment' is composed of all services which contribute to the traffic economies of scale in the network (e.g. mobile traffic on a mobile network). With such a large increment, incremental network common costs of all traffic will be taken into account.<sup>21</sup> The cost of each individual service is then derived according to the cost allocation rule used.<sup>22</sup> This approach shares equally the economies of scale benefits among all services.
61. In contrast, the '**pure LRIC**' approach considers as the increment the traffic created by a single service (e.g. voice call termination) (service A in the figure below). As a consequence, the associated incremental cost is the cost avoided when service A is not produced. This cost is the difference between the total cost for producing all services and the total cost of producing all services with the exception of service A. Under this approach, service A benefits to a great extent from economies of scale as neither network joint/common costs nor corporate overheads are taken into account in so far as they are

---

<sup>19</sup> And a very high marginal cost where that capacity becomes exhausted.

<sup>20</sup> A variant is the so-called **Total Element LRIC (TELRIC)** which defines each increment as an independent network unit (e.g. mobile network, fixed access network, core network etc...). This approach is currently followed by Batelco in its top-down model. Zain defines two increments in its mobile network top-down model (traffic sensitive and subscriber sensitive increments).

<sup>21</sup> Network costs can include connection fees (one-off charges).

<sup>22</sup> see section 3.4.

## Position Paper

### Development, implementation and use of fixed and mobile bottom-up network cost models

not incremental to the service increment considered. In other words, if all services were priced based on a pure LRIC approach, network common costs and corporate overheads would not be recovered. As a consequence, these common costs have to be allocated to other services than those being priced with a pure LRIC approach.

62. From a practical point of view, a bottom-up cost model can produce cost estimates in accordance with both the 'LRIC' and 'pure LRIC' standards. The 'pure LRIC' estimate for service A is calculated running the model two times: once with the whole set of services and once 'switching off' the service A. The difference between these two values gives the 'pure LRIC' of service A. 'LRIC' is calculated running the model once (with all the services).
63. At this stage, the treatment of corporate overheads needs to be considered. They can eventually be marked up (the approach is then sometimes referred to as 'LRIC+' in order to take into account all the costs of the operator modelled).<sup>23</sup>
64. Figure 1 summarises the differences between the pure LRIC approach and other forms of LRIC where the size of the increment varies according to the number of services included. For example, the pure LRIC of service A only captures the specific costs that are incurred when service A is produced. No joint or common costs are included. Distributed LRIC ('D-LRIC') is a variation of LRIC for which a share of joint and network common costs is allocated to the total incremental cost.
65. If the increment is defined more broadly to include services A, B, and C, the LRIC will include not only the service-specific costs of the three services, but also the costs that are jointly incurred across those services. Where the increment includes all services delivered over the network, the resulting LRIC will include service-specific costs and joint and common costs, while the LRIC+ (also referred to as D-LRIC+) will also include a mark-up to cover a portion of un-attributable costs (e.g. corporate overheads).
66. Once the LRIC of the increment (a service or group of services) is calculated, a cost per unit of service can be derived by dividing the LRIC by the increment output expressed in equivalent units (i.e. normalised among services by applying conversion factors). This cost per unit is called the Long Run Average Incremental Cost ('LRAIC') of the service.

---

<sup>23</sup> see section 3.4.

## Position Paper

### Development, implementation and use of fixed and mobile bottom-up network cost models

Figure 1: Example of variants of the LRIC methodology family

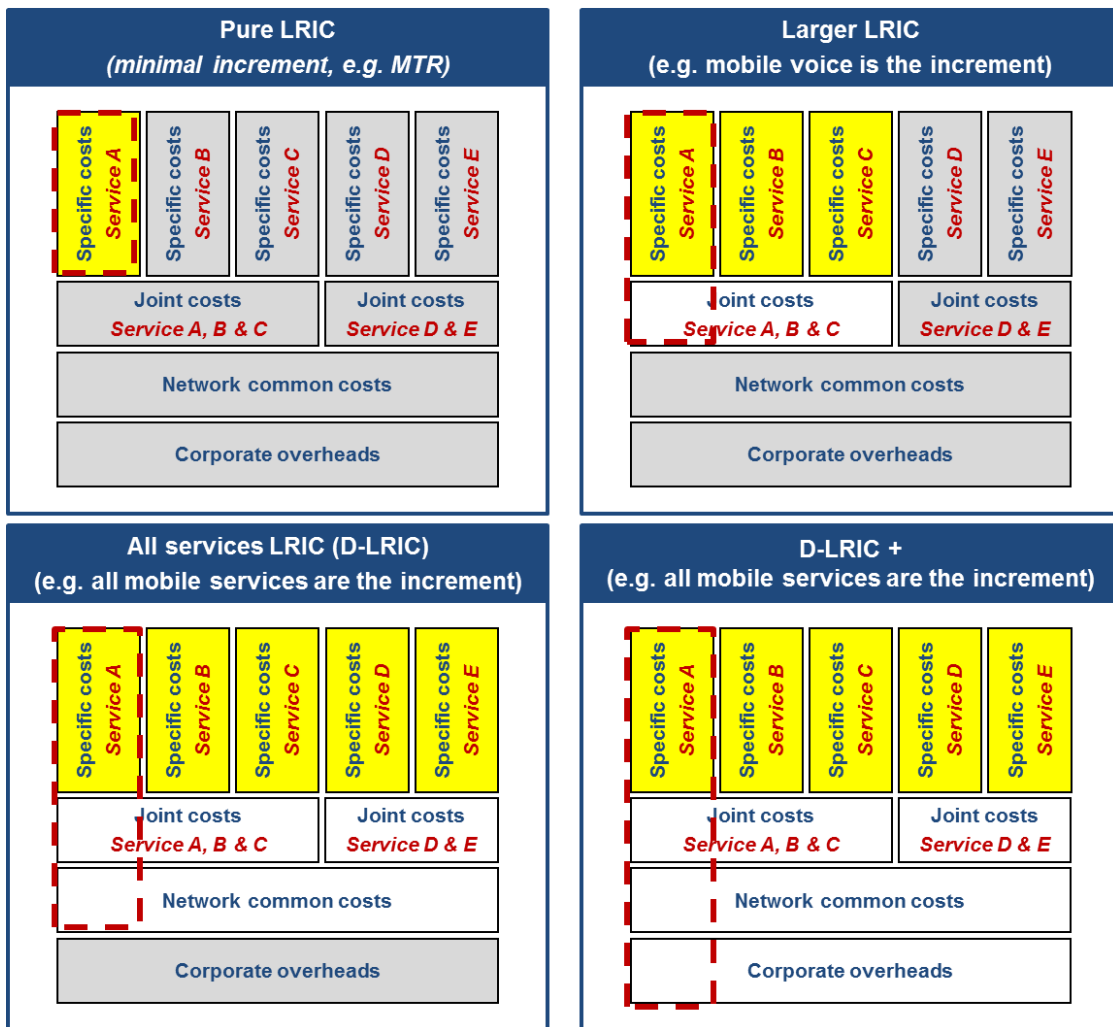

Source: the Authority

67. Historically, NRAs have used the LRIC+ approach (where un-attributable costs are included and where the increment is 'all services') while the pure LRIC approach is now increasingly used for termination rates.
68. In its 2009 recommendation on the regulation of termination rates, the European Commission recommends to use a pure LRIC approach in the specific case of termination charges in order to promote efficient production and consumption and to minimise potential competitive distortions. Indeed, the European Commission explains that if common network costs are included in the calculation of termination charges, this can lead to cross-subsidies between fixed and mobile operators.
69. However, if each service were to be priced according to the pure LRIC approach, joint and common network costs and corporate overhead costs would not be recovered or would have to be recovered from other services. In addition, under the pure LRIC approach, the resulting costs are likely to differ for services whose delivery involves the same network elements (such as call origination, which may be required to bear a significant proportion of joint and common network costs, and call termination, which will bear none of these costs).

## Position Paper

### Development, implementation and use of fixed and mobile bottom-up network cost models

70. In the Authority's view, it is therefore necessary to implement the LRIC+ approach at a minimum in the cost model to ensure overall cost recovery. The Authority is also of the view that the pure LRIC approach may be appropriate in some circumstances, such as in the fixed and mobile core networks for several services such as termination (as it is in Europe).
71. Therefore, the fixed core and mobile networks bottom-up models will be able to calculate for each increment its LRIC+<sup>24</sup> and for selected increments both the LRIC+ and the pure LRIC. The Authority will not calculate pure LRIC for services which account for a considerable proportion of traffic (e.g. leased lines, broadband access), This approach would be inappropriate as pure LRIC for such services could lead to cost recovery difficulties. The Authority will ensure that with the pure LRIC approach, network costs will be fully recovered by the operator by allocating non-specific costs of the service(s) for which the pure LRIC approach is applied to other service(s).
72. In the fixed access network, the increment is defined as the whole access network (TELRIC approach) and the Authority is therefore of the view that there is a unique way to assess the LRIC for the access network.<sup>25</sup> This is consistent with the legal framework since, as explained in section 2.1, tariffs shall be based on incremental costs.

**Key message 2:** The Authority will implement both the pure LRIC and LRIC+ approaches for services handled by the fixed core and the mobile networks. For fixed access network services, the increment is defined as the whole access network.

### 3.4 Which cost allocation approach should be used?

73. As noted earlier, joint and common costs are prevalent in telecommunications networks. For both mobile and fixed networks, several network elements are not specific to a given service but are required to provide a set of services. The allocation of network costs between different services is a key issue for network costing as:
- a. Mobile networks share many services: SMS, voice, data, etc.;
  - b. The fixed core NGN network can support many services: voice, data products, TV, Video-on-Demand ('VoD'), Internet, etc.;
  - c. In the access network, trench costs can be shared between copper and fibre.
74. In the case of Bahrain, the allocation of costs between services presents further specificities, some of which are presented below.

---

<sup>24</sup> LRIC + gives similar results regardless of the size of the increment as it includes a contribution for joint and common network costs as well as for corporate overheads.

<sup>25</sup> In so far as all the costs of the access network are specific to the access network (i.e. there is no or marginal sharing of cost between the core and access), the choice between pure LRIC and LRIC+ is a false choice as the pure LRIC and the LRIC+ approach would give similar outcomes.

## Position Paper

Development, implementation and use of fixed and mobile bottom-up network cost models

75. For example, Zain has a core network which is shared between mobile services and Wimax broadband services. As a consequence, the modelling of Zain's network costs will need to take into account the allocation of network costs between mobile services and Wimax services.
76. A similar issue arises in the case of Batelco whose fixed core network also supports mobile traffic. However, this mobile traffic can be seen as leased line traffic handled by the fixed core network which ensures a non-discriminatory treatment of this traffic compared to other leased lines.
77. Further, with NGN core networks, the proportion of common cost is typically greater than with legacy network.<sup>26</sup> This makes the question of how to allocate common and joint costs more acute.
78. As the LRIC+ approach implies that joint and common costs are allocated across multiple services, as does the LRIC+ approach, the Authority will give careful consideration to the way in which such joint and common costs are allocated. The allocation of joint and common costs is a complex task.

### Joint and common network costs

79. Different allocation keys can lead to very different unit costs for a given service. This is especially the case for NGNs given the increasing demand for services such as data, Internet or VoD. As a result, unit costs that include cost allocations based on bandwidth result in low unit cost for voice services. Similar changes can be observed with mobile networks which are increasingly used to provide data services.
80. Several allocation rules are generally described in economic theory, such as:
  - a. in the 'proportional rules family' (technical allocation): equi-distribution, required capacity, Moriarty, residual benefit, and Equi-Proportionate Mark-Up (EPMU); and
  - b. in the 'game-theory rules family' (economic allocation): Shapley-Shubik or nucleolus.
81. In the next paragraphs, a high level discussion of cost allocation rules is provided (a detailed presentation is included in Annex A – Cost allocation).
82. Each allocation rule has its advantages and drawbacks, although the required capacity allocation rule and the Shapley-Shubik rule are the most common methodologies considered and/or used by NRAs for allocating joint and common network costs.
83. The required capacity allocation approach allocates common and joint costs based on the capacity used by each service at the busy hour (i.e. a 60-minute period during which the maximum total traffic load occurs). This has been the traditional approach followed in telecommunications because many costs are traffic sensitive and networks are dimensioned to support the peak of traffic. Under a strict cost causation principle, the dimension of the network is traffic-dependent and thus network costs are allocated accordingly.

---

<sup>26</sup> See Commerce Commission, Discussion Paper on Next Generation Networks, 24 December 2008 "While the next generation multi-service IP core network should result in lower costs in the longer term, as a common platform is used to deliver multiple services, there will be a higher proportion of common costs compared to legacy networks." (page 18)

## Position Paper

### Development, implementation and use of fixed and mobile bottom-up network cost models

84. The Shapley-Shubik rule has also been considered by some NRAs such as ARCEP in France<sup>27</sup> or ComReg<sup>28</sup> in Ireland. The Shapley-Shubik allocation approach consists of setting the cost of a service equal to the average of the incremental costs of the service after reviewing every possible order of arrival of the increment (see Annex A – Cost allocation for more details). The Authority is of the view that such an approach may be worth considering because the required capacity allocation rule may have some drawbacks in some specific cases. For example, with the required capacity allocation rule, the voice service may be allocated a very small share of common network costs because it uses much less capacity compared to other services. Therefore, the voice service may bear very low costs, which could contrast with the value of the voice service as perceived by market players and consumers. In such a case, the Shapley-Shubik allocation rule may provide a more appropriate outcome.
85. The Authority will implement the required capacity (also called ‘capacity based’) allocation method in the bottom-up models for common network costs, as this approach allocates such network costs in accordance with the capacity required by each service and thus conforms to the principle of cost-causation. In addition to this allocation method, the Authority will also implement the Shapley-Shubik allocation method. This method has been considered by some NRAs and can provide useful insights.

**Key message 3:** The Authority will implement both the required capacity and the Shapley-Shubik allocation methods for joint and common network costs in the bottom-up models.

### Un-attributable costs (corporate overhead)

86. In addition to network costs, an operator faces non-network common costs such as the costs of maintaining a corporate office which are incurred to support all functions and activities. Examples of these costs include costs associated with head office buildings, senior management and internal audit.
87. Identifying the impact of an increment on corporate overheads is a very complex task. This is illustrated by the following quote from the Danish regulatory authority NITA/ITST:

*“It is often argued that many overhead costs are common costs, for example the costs of the legal department and the chairman’s salary. This is only correct to the extent that it is not possible to identify how a specific increment affects the overhead cost at hand. Using the ABC approach outlined in Chapter 8, however, it should be possible to establish a causal relationship between these costs and final activities in most cases. Having said that, some overhead costs might not warrant the effort involved in the analysis and might better be recovered via a mark-up.”<sup>29</sup>*

---

<sup>27</sup> See ARCEP, decision n° 2008-0896.

<sup>28</sup> See ComReg, decision n° D03/08.

<sup>29</sup> NITA/ITST – Model Reference Paper – 2008

## Position Paper

### Development, implementation and use of fixed and mobile bottom-up network cost models

88. These costs are potentially material and should be recovered if appropriate.<sup>30</sup> According to the European Regulators Group (ERG),<sup>31</sup> the methodology traditionally used by NRAs to allocate these costs is the EPMU approach:<sup>32</sup>

*“In a regulatory environment it is accepted that all services should bear, in addition to their incremental cost, a reasonable proportion of the common costs. The preferred method of allocating common costs is Equal Proportionate Mark-Up (EPMU).”*

89. Under the EPMU approach, each service is allocated a share of the common costs in proportion to that service’s share of total attributable costs. While the EPMU approach is relatively simple to implement, the main drawback of this approach is that it does not take into account efficiency considerations.
90. An alternative method is known as ‘Ramsey-Boiteux pricing’. According to economic theory, efficiency is maximised when prices are set equal to marginal costs. However, because of the existence of fixed and common costs, Ramsey-Boiteux prices include a mark-up on the marginal cost of each service in order to contribute to the joint and common costs. The size of the mark-up on each service is inversely proportional to the price elasticity of demand for that service, as this minimises the consumption-distorting effect of raising prices above marginal cost.<sup>33</sup> As a result, welfare is maximised.
91. The economic literature often presents Ramsey-Boiteux pricing as the theoretically optimal approach to allocate common costs from an economic welfare stand-point. However, most regulators recognise the significant difficulties in estimating Ramsey-Boiteux prices, in particular the need for accurate estimates of own- and cross-price elasticities, and hence Ramsey-Boiteux mark-ups are generally not used by regulators for allocating joint and common costs.<sup>34</sup> The difficulties inherent to such approach have been recognised by many regulatory authorities or economists:

*Ofcom stated in March 2011: “Consistent with the view reached in other proceedings, full application of Ramsey pricing is computationally very difficult and highly prone to regulatory error” and added “mobile markets (including MCT) are not easily amenable to Ramsey pricing analysis”.<sup>35</sup>*

*“Academic economists and policymakers both often argue that regulators do not have the information to set Ramsey prices”.<sup>36</sup>*

*“While regulators could try and approximately implement such global Ramsey pricing formulas, there have been no known attempts to do so”.<sup>37</sup>*

---

<sup>30</sup> Article 6.2.3 of the Accounting Separation Regulation dated 2 August 2004 limits un-attributable cost to less than 10% of overall costs.

<sup>31</sup> ERG was the predecessor to the Body of European Regulators for Electronic Communications (BEREC).

<sup>32</sup> ERG - Recommendation on how to implement the commission recommendation C(2005) 3480 - 2005

<sup>33</sup> See Laffont and Tirole, 2001, Competition in Telecommunications, Cambridge: MIT Press, for more detailed on Ramsey-Boiteux pricing.

<sup>34</sup> Assessment whether a Ramsey-pricing methodology can be implemented for setting the Local Loop Unbundling (“LLU”) Line Share (“LS”) price in Ireland, ComReg, 18 August 2009.  
Assessment of Vodafone’s mobile terminating access service (MTAS) Undertaking, ACCC Final Decision March 2006.

<sup>35</sup> Ofcom, Wholesale mobile voice call termination Statement, March 2011

<sup>36</sup> Laffont J-J., Tirole J. (2000).

<sup>37</sup> Vogelsang I. (2006).

## Position Paper

Development, implementation and use of fixed and mobile bottom-up network cost models

*“This requires a substantial amount of information, particularly as the impact of one service’s price on the demand for other services has to be taken into account. It is also very important that market rather than company elasticities of demand are used to set prices, because otherwise all the shared and common fixed costs end up being recovered from services where there is little or no competition.”<sup>38</sup>*

92. Given the empirical difficulties associated with Ramsey pricing, and that the EPMU approach is widely used for allocating unattributable costs (this is for example the case in Batelco’s top-down models)<sup>39</sup>, the Authority will implement the EPMU approach for the allocation of common non-network costs.

**Key message 4:** The Authority will allocate un-attributable costs (non-network common costs) on the basis of the EPMU approach.

## 4 Methodological issues involved in bottom-up cost modelling

93. When developing and implementing a bottom-up cost model, several options are available. The development of a bottom-up cost model therefore firstly requires a discussion on several methodological issues that have significant implications on the development and implementation of the model.
94. The aim of this section is to introduce the main methodological issues, to analyse the possible approaches and their potential impact on the development of bottom-up cost models and to finally define which approach will be followed by the Authority.
95. For the purposes of this document, the methodological issues related to bottom-up cost models have been grouped into the following categories:
- a. Technical issues (see §4.1);
  - b. Financial issues (see §4.2);
  - c. The charging basis (see §4.3);
  - d. The use of gradients to set regulated prices (see §4.4)
  - e. The period of time to be covered by the model (see §4.5)

### 4.1 Technical issues

96. Technical issues relate to the type of network and the type of operator that is being modelled. This section discusses and sets out the Authority’s views on the following technical issues:
- a. Scorched node versus scorched earth;

---

<sup>38</sup> Comreg, Decision D8/01.

<sup>39</sup> See also *Annex C – International regulatory approaches*.

## Position Paper

### Development, implementation and use of fixed and mobile bottom-up network cost models

- b. Type of operator modelled;
- c. Technologies to be modelled;
- d. Limit between access and core;
- e. Network dimensioning optimisation approach to be modelled;
- f. Services to be modelled (wholesale level);
- g. Treatment of OPEX.

### Scorched node versus scorched earth

97. In bottom-up models, one key network design assumption is related to the question of whether (and if so, to what extent) the existing network topology should be taken into account. Two approaches regarding the location of core network nodes are usually proposed: 'scorched node' and 'scorched earth'. The scorched node approach uses the location of the existing network nodes and then builds an optimised network within the constraint of those existing nodes, whereas the scorched earth approach (also called a 'greenfield' approach) tends to build an ideal topology that is unconstrained by the existing network.
98. For a mobile network, the 'scorched node' approach consists of keeping the existing location of base stations as an input for the model. The rationale for this approach is that base station location is subject to many constraints. These include technical constraints (such as the need for high points of presence to ensure optimal coverage) but also administrative constraints that cannot be easily modelled. For example, mobile operators are facing increasing difficulties to find base station sites due to local authorities sometimes imposing limitations on the density and/or location of base stations.
99. For a fixed network, choosing a 'scorched node' approach means keeping the existing exchange location as an input for the model. As for mobile networks, the rationale is that existing sites were chosen in the past following demographic, geographic and technical studies. These studies take into account constraints that might be difficult to consider when modelling an ideal topology.
100. The scorched node approach is often preferred by NRAs.<sup>40</sup> For example, the ERG strongly supported the scorched node approach on pragmatic grounds:<sup>41</sup>
- "Designing an optimal network topology is not a straightforward task. For feasibility reasons, it is appropriate to take the existing network topology as the starting point for the cost allocation process. Such a scorched node approach would imply that the existing points of presence are maintained but that technologies are optimised consistent with there being an actual or potential new entrant or efficient competitor."*
101. Retaining the location of the existing nodes does not necessarily mean that potential inefficiencies should not be addressed. The ERG recommended that inefficiencies should be eliminated even if the scorched node approach is chosen.<sup>42</sup>

---

<sup>40</sup> See Annex C – International regulatory approaches on methodological issues.

<sup>41</sup> ERG - Recommendation on how to implement the commission's recommendation C(2005) 3480 - 2005

<sup>42</sup> *ibid.*

## Position Paper

### Development, implementation and use of fixed and mobile bottom-up network cost models

*“It can be appropriate to modify the scorched node approach in order to replicate a more efficient network topology than is currently in place. Such a modified scorched node approach could imply taking the existing topology as the starting point, followed by the elimination of inefficiencies. This may involve changing the number or types of network elements that are located at the nodes to simplify and decrease the cost of the switching hierarchy. Other important issues in this respect are how to deal with spare capacity in the network and the existence of stranded costs. When the modified scorched node approach is not applicable because the elimination of inefficiencies is not practical, it could be more appropriate to use a scorched earth approach.”*

102. For the reasons exposed above, the Authority will use the scorched node approach for both fixed and mobile models because it is based on a more achievable and realistic level of efficiency. In the event that obvious inefficiencies are observed, adjustments could be made in accordance with best practices.

**Key message 5:** The Authority will use the scorched node approach for both the fixed and mobile models. In the event that obvious inefficiencies are observed, adjustments could be made in accordance with best practices.

### Type of operators modelled

103. When implementing the cost models, the Authority will rely on information provided by operators related to the price of assets paid, OPEX and local engineering rules, as long as it is reasonable to use this data. However, several ‘operator profiles’ can be proposed. Some models aim at replicating existing market operators<sup>43</sup> whereas other models design a ‘generic operator’ that is different from any existing operator.
104. Modelling existing operators’ profiles enables cost differences that may exist between operators and the drivers of those differences to be identified.
105. There are a number of parameters to be chosen to model a ‘generic operator’. The most significant ones include:
- a. Operator’s market share;
  - b. Network technology (e.g. for mobile: 2G, 3G...); and
  - c. Choice for the backhaul (e.g. leased lines, radio links, own infrastructure, etc...).
106. The ‘generic operator approach’ has several benefits such as enabling a model to be published without providing confidential data coming from the operators. It is also easier to implement as a single model is used for all operators.
107. There are several ways to model a ‘generic operator’. A common approach is to construct an ‘average’ operator, whose structure would be based on the actual operators. Another approach is to model a new entrant coming into the market. A ‘generic operator’ would use efficient forward-looking technologies.

---

<sup>43</sup> Existing operators are modelled with actual market share, network traffic and coverage.

## Position Paper

Development, implementation and use of fixed and mobile bottom-up network cost models

108. An important parameter when designing a 'generic operator' is to set an appropriate level of economies of scale. In 2009, the European Commission completed a detailed review of available options for the definition of generic operators in the context of fixed termination rates and mobile termination rates (MTRs).
109. For fixed network modelling, the European Commission underlined the difficulties of setting the appropriate level of economies of scale. A smaller operator could be able to compete covering smaller areas. In addition, the availability of wholesale (regulated) products could enable small operators to benefit from the economies of scale of larger operators.<sup>44</sup>

*"When deciding on the appropriate single efficient scale of the modelled operator, NRAs should take into account the need to promote efficient entry, while also recognising that under certain conditions smaller operators can produce at low unit costs by operating in smaller geographic areas. Furthermore, smaller operators which cannot match the largest operators' scale advantages over broader geographic areas can be assumed to purchase wholesale inputs rather than self-provide termination services."*

110. For the fixed core and fixed access cost models, the Authority will model Batelco's networks. Batelco is indeed the fixed incumbent operator and is the only fixed regulated operator with a national coverage for both the fixed access network and the fixed core network.
111. For mobile network modelling, two approaches can be used to define the relevant market share of the generic operator. Either the market share of the generic operator can be defined as '1/Number of operators', i.e. 33% in the case of Bahrain; or the approach followed by the European Commission in its 2009 recommendation could be used, i.e. the market share of the generic operator could be set at 20%.<sup>45</sup>

*"To determine the minimum efficient scale for the purposes of the cost model, and taking account of market share developments in a number of EU Member States, the recommended approach is to set that scale at 20% market share."*

112. Given the current market shares of the three mobile network operators in Bahrain, the Authority considers that the European Commission's assumption of minimum efficient scale at 20% is not relevant for the purposes of modelling a generic mobile operator in Bahrain. The Authority's view is that the generic operator should be modelled with a 33% market share.
113. Where there are significant cost differences between the operators, the 'generic operator approach' could lead to unit costs being unachievable for some operators. In this case, modelling based on each of the existing market operators might be preferred. This case has been explained by the GSMA in its best practice paper on the setting of MTRs:<sup>46</sup>

*"In deciding on a particular approach, a NRA should be mindful of whether there is an expectation that there are fundamental cost differences between the different operators, and whether or not these differences could be quantified in a hypothetical model. If there are differences which cannot be*

---

<sup>44</sup> European Commission – Explanatory note on the recommendations of TR - 2009

<sup>45</sup> European Commission – Explanatory note on the recommendations of TR - 2009

<sup>46</sup> GSMA – The setting of mobile termination rates, best practice in cost modelling - 2008

## Position Paper

### Development, implementation and use of fixed and mobile bottom-up network cost models

*easily quantified in a hypothetical model, it is our opinion that individual operator models should be built to ensure that the NRA reduces the risk of setting a termination rate that is unachievable for one or more of the operators in the market.”*

114. As Batelco, Zain and Viva may potentially incur different costs, the Authority will model the network of each operator. This is without prejudice to the Authority’s position that MTRs should be symmetrical.<sup>47</sup>

115. In addition, the Authority will develop and implement a ‘generic operator model’:

- a. The generic operator will be designed with a reasonable level of economies of scale. A 33% market share will be used (average market share in a 3-player context) because 20% market share is too low for current operators.
- b. The network demand of the generic operator will be determined in such a way that its subscribers’ average usage (both in quantity and mix of services) will follow market average.
- c. The Bahraini generic mobile network will be built based on technologies used by operators (combination of 2G and 3G).
- d. If an operator was to deploy a new mobile network in Bahrain, it would benefit from the latest technology available at the moment and accordingly, it would deploy its network in the most efficient manner. Such deployment is likely to share more similarities with Bahrain’s latest mobile entrant. The network topology of the generic mobile operator will therefore follow Viva’s mobile network as determined by the scorched node approach. The generic topology will be subject to possible adjustments to reflect the generic operator’s spectrum assignment (refer to Table 3), potential differences in the number of base stations, and potential differences in mobile traffic load.
- e. Among mobile operators, distinct backhaul infrastructures are used:
  - i. Batelco uses both its fixed core network and microwave-based systems for mobile backhaul. Thus for the purposes of modelling cost, the Authority will use both leased lines and microwave links for Batelco’s mobile backhaul;
  - ii. Zain and Viva use microwave-based systems to provide backhaul for the great majority of their base stations.

While a generic operator with no fixed network may use microwave transmissions in the same way Zain and Viva currently do, the Authority will identify through the development of the models the most efficient type of backhaul of the generic operator among several other possibilities including own fixed infrastructure or Batelco’s leased lines. This decision will be taken considering the forward looking traffic faced by operators.

---

<sup>47</sup> The Authority, 1 February 2010, The Regulation of Mobile Termination Services, Position Paper.

## Position Paper

Development, implementation and use of fixed and mobile bottom-up network cost models

**Key message 6:** For the fixed access and fixed core models, the Authority will model Batelco's network. For mobile networks, both the operators' specific models and the generic operator model will be implemented.

### Technologies to be modelled

116. In order to model the network of an operator (either mobile or fixed), a key choice relates to the technology to be modelled. This question encompasses a set of technological issues that aim to define modern/efficient standards (amongst them topology and spectrum standards) for delivering services. Proven, available and lowest cost technologies should be used in the model as it enables the calculation of efficient current costs.

### Mobile models

117. For modelling the costs of a mobile operator, a number of technological options are available. Successive generations of technologies have been rolled out over time, with the most significant steps being the transition to digital GSM (2G) and the introduction of UMTS network elements (3G). Technological change is still ongoing, with Long Term Evolution ('LTE') deployments already planned in several countries, including Bahrain.

118. The three mobile operators in Bahrain (Batelco, Zain, and Viva) have deployed both 2G and 3G technologies. Therefore it makes sense to model both 2G and 3G technologies. This is consistent with the European Commission's recommendation to model a combination of 2G and 3G technologies.<sup>48</sup> As a consequence, the Authority is of the view that a combination of both 2G and 3G technologies should be modelled. However, in case the LTE technology is commercially launched and deployed to a significant extent between 2011 and 2015, the Authority will consider updating the model to include this technology in the modelled radio access network.

119. Another relevant issue related to the modelling of mobile network costs is the quantity and type of spectrum of each operator that should be taken as an input to the model. Indeed, all else being equal the larger the spectrum bands assigned to an operator, the lower the number of base stations required and thus the lower its costs.<sup>49</sup> In addition, the lower the assigned frequencies are in the spectrum, the lower the deployment costs tend to be (this

---

<sup>48</sup> European Commission – Explanatory note on the recommendations of TR - 2009 “Just as in fixed networks, a forward-looking perspective would imply that all services will be delivered over an IP core network. A BU model built today could assume that the core network is NGN-based, to the extent that the costs of such a network can be reliably identified. Similar issues arise in relation to the mobile access network as compared to the fixed access network. In the same way as fibre to the node or to the home is replacing copper, so too are 3G- or UMTS-based technologies gradually replacing 2G. Some very important differences remain. In mobile networks economic conditions driven by demand concentration and geographic characteristics influence the selection of a range of spectrum-based technologies to match those conditions. It can be expected that 2G and 3G networks are likely to co-exist for a number of years. Hence, the model should be based on both 2G and 3G employed in the access part of the network to reflect the actually anticipated situation facing operators, while the core part could be assumed to be NGN-based.”

<sup>49</sup> This is true up to a certain extent. Indeed, up to a certain amount of spectrum, it may be that additional quantity of spectrum does not enable cost savings.

## Position Paper

Development, implementation and use of fixed and mobile bottom-up network cost models

is particularly the case for the IMT 900 MHz frequency band which possesses better signal propagation characteristics and allows better coverage than higher frequency bands such as the 1800 or 2100 MHz bands). As a consequence, the question of the frequency band, the bandwidth and the multiplexing scheme of assigned spectrum blocks is important in the development of mobile cost models.

120. In Bahrain, mobile operators are currently using a combination of GSM 900, GSM 1800, 3G FDD and 3G TDD spectrum blocks, as summarised in Table 2.

**Table 2: Mobile operator spectrum assignment in Bahrain**

Assignments Total bandwidth (MHz)	Batelco	Zain	Viva
<b>GSM 900</b>	23,6	24,0	11,2
<b>GSM 1800</b>	40,0	50,0	30,0
<b>3G FDD</b>	20,0	30,0	30,0
<b>3G TDD</b>			5,0

Source: the Authority

121. Batelco, Zain and Viva therefore have different spectrum assignments. In the context of Bahrain, if these differences in spectrum assignment were to generate material cost differences (due to a different number of base stations required), these differences would be captured in modelling the individual mobile operators.

122. In the case of the 'generic operator approach', the Authority proposes to use an average spectrum assignment as shown in Table 3.

**Table 3: Proposed spectrum assignment for the generic operator**

Assignments Total bandwidth (MHz)	Generic operator
<b>GSM 900</b>	20,0
<b>GSM 1800</b>	40,0
<b>3G FDD</b>	25,0
<b>3G TDD</b>	-

Source: the Authority

123. The Authority will take into account 'licence fees' in its modelling exercise since it represents a cost to operators. 'Licence fees' include the following 4 categories:

- a. Licence fee: one-off payment to acquire the right to operate and commercialise telecommunications services in the Kingdom of Bahrain;
- b. Annual licence fee: annual payment expressed as a percentage of the gross revenues (currently set at 0.8%);
- c. Frequency licence fee: one-off payment to acquire the right to use certain frequency bands; and

## Position Paper

Development, implementation and use of fixed and mobile bottom-up network cost models

- d. Annual frequency licence fee: annual payment proportional to the quantity of spectrum used.

124. 'Licence fees' should be categorized as network costs rather than retail costs because licences relate to the operation of a network (a MVNO does not pay any licence)<sup>50</sup>. In that regard, the Authority concurs with the GSMA statement on licence fees: *"In our opinion, general licence fees are typically a common cost for the whole business and should be recovered in the same way as general business overheads. Licence fees that specifically relate to spectrum can be recovered in the same way as other radio network assets"*<sup>51</sup>. The Authority intends to include two options for licence costs in the 'generic operator' model:

- a. use of average licence costs. This approach is consistent with the use of average spectrum assignments as described in the preceding paragraph; or
- b. use of latest entrants' licence costs. Indeed, the latest entrants' licence costs are supposed to better reflect the real value of such a licence in a competitive environment with 3 operators.

In any case, the bottom-up models will be flexible enough to test several levels of licence costs and to complete sensitivity analysis for licence costs.

**Key message 7:** The Authority will model both 2G and 3G technologies. However, in case the LTE technology is commercially launched and deployed to a significant extent between 2011 and 2015, the Authority will consider updating the model to reflect this technology.

**Key message 8:** The Authority will consider the spectrum allocated to each operator for specific models and the average allocated spectrum when modelling the network of a generic operator. The network's topology of the generic operator will follow Viva's network topology to which adjustments may be made to reflect the average allocated spectrum.

**Key message 9:** The Authority will treat non spectrum-related license fees as a common cost whereas spectrum-related license fees will be treated as a network cost. For the generic operator, the Authority will use both the average licence costs and the latest entrants' licence costs. In any case, the bottom-up models will be flexible enough to test several levels of licence fees' costs and to conduct sensitivity analysis for this input.

---

<sup>50</sup> If MVNO were to pay licence fees, then a sensitivity analysis could be carried out to assess the impact of allocating the amount of licence fees paid by MVNOs to retail costs also.

<sup>51</sup> GSMA, The setting of mobile termination rates: Best practice in cost modelling, 2008

## Position Paper

Development, implementation and use of fixed and mobile bottom-up network cost models

### Fixed core model

125. Over the last few years, Batelco has deployed an NGN core network. If a greenfield operator were to roll out a new fixed core network today, it would likely choose a packet-switched network with services delivered over an IP core network, i.e. NGN core. As a consequence, a cost model built with a forward-looking view should consider a NGN-based core network.
126. The Authority is therefore of the view that a NGN core network should be modelled using the same architecture and technologies as those used by Batelco, i.e. based on a scorched node approach and taking into account the mix of Ethernet and IP-MPLS over SDH technologies as described in Figure 2. The Authority considers that it would not make sense to model the costs of legacy networks such as the PSTN network. The Authority notes also that there is a separate SDH network for the provision of CAT and LLCOs services.

Figure 2: Batelco's NGN network

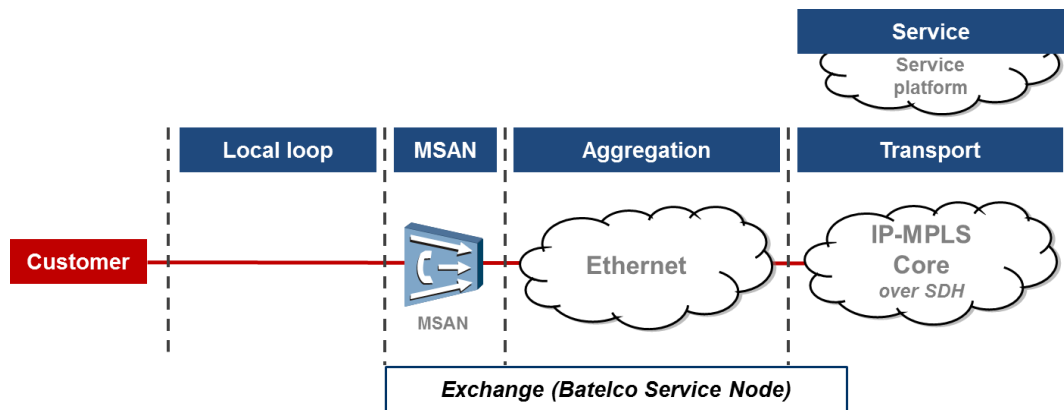

Source: the Authority

127. As the vast majority of services share the same equipment and assets (e.g. ducts) in Batelco's network, the question of which cost allocation methodology should be used is of utmost importance for the fixed core network (see section 3.4).
128. The Authority intends to model the core network with and without a media gateway to reflect the two types of NGN: (a) NGN with Media Gateway (to communicate with the PSTN world); and (b) pure NGN without Media Gateway. The NGN without Media Gateway is the most forward-looking network as it implicitly assumes that there are no longer PSTN networks.

Finally, in the Authority's view, it is important that any modelling take into account any plans that Batelco may have regarding the evolution of its core network in the medium term (over the next 3 to 5 years) (such as the introduction of new technologies, removal of the SDH transmission network) to give a picture of forward-looking costs.

## Position Paper

Development, implementation and use of fixed and mobile bottom-up network cost models

**Key message 10:** For the fixed core network, the Authority will model Batelco's existing NGN core network. Two types of NGN will be modelled: with and without a Media Gateway. The Authority will also model a separate SDH network which is currently used for the provision of certain leased lines services.

### ***Fixed access model***

129. The main access technology currently used in Bahrain for voice, low-speed leased lines and broadband services is copper. The Authority will therefore model the bottom-up costs of the copper access network.
130. However, in many countries, some operators are currently deploying fibre in the access networks. Those networks are generally referred to as Next Generation Access (NGA) networks and take the form of fibre to the home (FTTH) or more generally FTTx, where x refers to the point at which the fibre terminates (such as the street cabinet). This is also the case in Bahrain where:
- a. The government announced in 2010 that a National Broadband Network (NBN) would be established in Bahrain.<sup>52</sup> The decision was taken to make available on an open access basis the capacity on the fibre network of the Electricity and Water Authority (EWA).
  - b. An FTTH network has already been deployed and is commercially available in Amwaj islands.
  - c. Some operators have plans to roll-out a FTTH network in Bahrain.<sup>53</sup>
131. As a consequence, the Authority intends also to develop a bottom-up model calculating the costs of a fibre access network built both as an overlay of the current copper network or as a standalone network. This will enable the modelling of both a network based on existing ducts and trenches and a network deployed by an operator starting from scratch. When building this model, the Authority anticipates that it will take into consideration, if relevant, sharing of trenches between copper and fibre.
132. Different architectures can be considered for the deployment of fibre access networks. As fibre has not yet been deployed on a national scale, choice(s) of architecture(s) would have to be made for the access cost model:
- a. On the one hand, a choice between fibre to the street cabinet / fibre to the curb / fibre to the basement / fibre to the home;
  - b. On the other hand, a choice between point-to-point architecture (as used in Ethernet P2P technology), and point to multipoint architecture (as used in GPON technology).

---

<sup>52</sup> "Statement of Government Policy with respect to the establishment of a National Broadband Network for the Kingdom of Bahrain", dated 4 July 2010.

<sup>53</sup> "2Connect launches FTTH services in Bahrain", 25 November 2010, <http://www.telecompaper.com/news/2connect-launches-ftth-services-in-bahrain>.

## Position Paper

Development, implementation and use of fixed and mobile bottom-up network cost models

Figure 3: Possible scenarios for the fixed NGA network

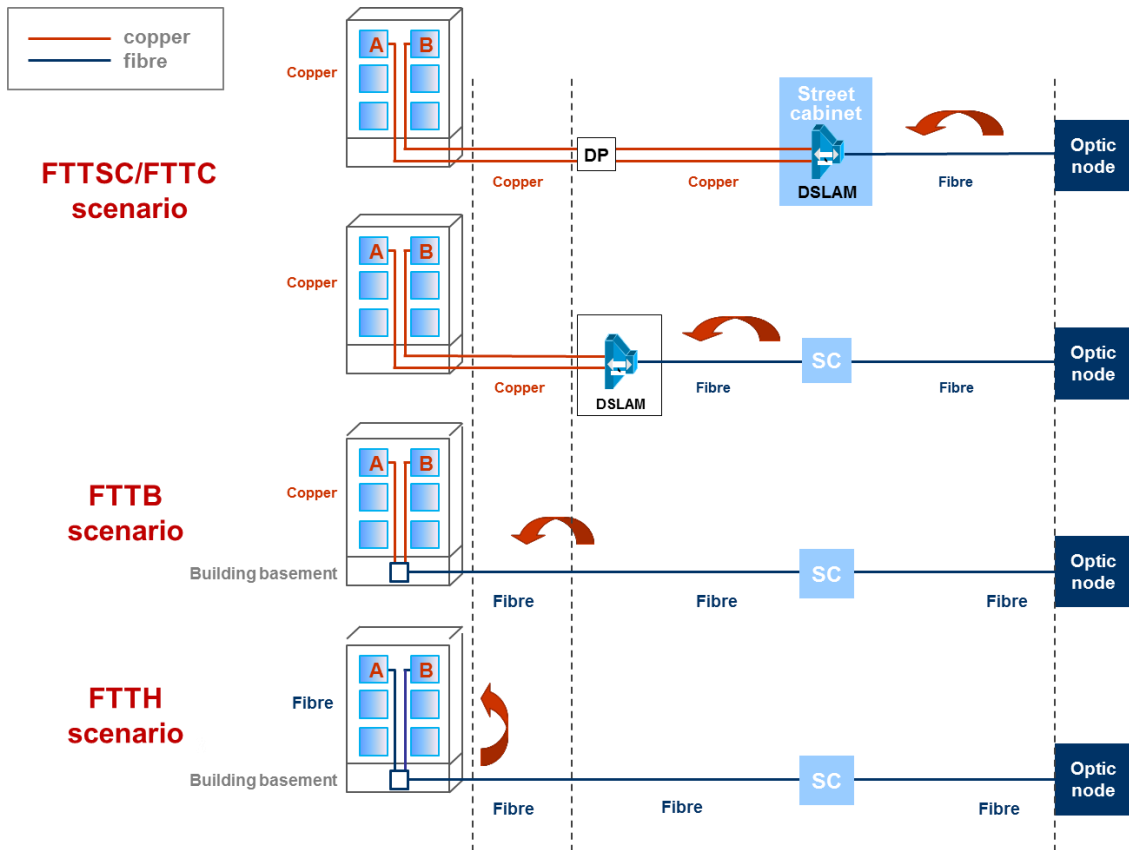

Source: the Authority

133. The fibre topology modelled should be *prima facie* the topology that is likely to be deployed in the medium term. The Authority's view is that a fibre deployment based on a point-to-point ('P2P') architecture is preferable,<sup>54</sup> as such a deployment provides a dedicated fibre pair to each end-user without the need to employ splitters and share capacity in the access network. As a result, a P2P deployment is more 'future-proofed' and better able to accommodate future growth in bandwidth demand. P2P is also better from a consumer choice standpoint as it provides more flexibility in terms of competitive access, including access at the layer 1 level with fibre loop 'unbundling'.<sup>55</sup> The Authority therefore considers that the cost model for the fixed access network should cover a P2P FTTH architecture.

134. For the access network model, the Authority will model the cost of a copper network along with the cost of a P2P FTTH architecture. The model will calculate the cost of provisioning fibre accesses to end-users for two scenarios: a first scenario whereby the FTTH network is deployed as a stand-alone network (no sharing with existing infrastructure) and a second scenario where it is built as an overlay of the current copper network (existing

<sup>54</sup> As explained in "Draft Position Paper on the Deployment of Telecommunications Networks in New Property" issued by the Authority on 27 May 2009.

<sup>55</sup> Ofcom has previously referred to the difficulties of fibre unbundling under a GPON architecture. According to Ofcom, "Given that there is likely to be a high number of passive splitter locations and that the process for disconnecting/reconnecting end user fibres will require significant manual intervention, this type of fibre unbundling is likely to be costly and impractical". Ofcom, *Review of the wholesale local access market*, 23 March 2010, paragraph 7.44.

## Position Paper

Development, implementation and use of fixed and mobile bottom-up network cost models

ducts and trenches will be shared for both copper and fibre cables wherever possible). For informational purposes, the Authority will also implement an 'ad hoc' assessment of the cost of a GPON deployment (as a discount on the P2P cost based on international benchmarks).

**Key message 11:** For the access network, the Authority will model the cost of a copper network along with the cost of a P2P FTTH architecture. Two scenarios for the P2P fibre deployment will be modelled: a) a greenfield deployment and b) an overlay deployment on top of the current copper network. For informational purposes, the Authority will also perform an 'ad hoc' assessment of the cost of a GPON fibre deployment (as a proportion of the P2P cost, based on international benchmark).

### Limit between access and core (line card)

135. The limit between the core and the access network has to be clearly set in the cost model. It may drive the scope of the costs included in the model for several services such as interconnection.
136. From an operator point of view, the core-access limit is usually set at the line card level as illustrated in Figure 4.

**Figure 4: Demarcation between fixed access and core network**

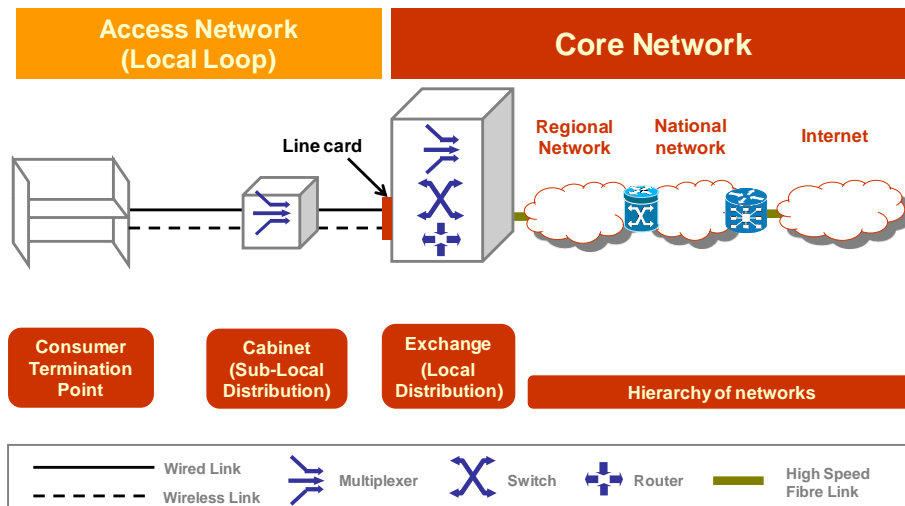

Source: the Authority

137. When modelling network costs, the common practice is to consider passive assets as part of the access network model and active assets as part of the core network model. The passive equipment (ducts and trenches) used by the core network are first calculated in the access network model and then used as inputs in the core network model.
138. From an economic point of view, the key difference between the access and the core network is that access network costs are non-traffic sensitive (line-related costs) whereas

## Position Paper

### Development, implementation and use of fixed and mobile bottom-up network cost models

most core network costs are traffic sensitive. The number of line cards is a non-traffic sensitive cost. From a pricing perspective, line cards should rather be considered as part of the access network because these costs are dedicated per user and hence generally recovered from rental charges.

139. Although the cost of the line cards will be calculated in the core network model for convenience purposes, its cost will be part of the access network costs.

### Network dimensioning optimisation approach

140. In bottom-up models, there are two different approaches to dimensioning a network and optimising its costs for a given service and/or traffic demand: the 'yearly' and the 'historical' optimisation approaches. The two methods have different mechanisms when it comes to calculating annual investment, as explained below.

- a. **The yearly approach** estimates the number of assets for a given year without taking into account what was previously built. While this approach 'rebuilds' the network every year independently from historic investments, it can include a forward looking view by taking into account traffic growth forecasts (e.g. optimise year 2011 with 2014 traffic forecast if this reflects current engineering rules). The yearly approach produces a better 'build or buy' signal to operators. Under this approach, the results of the model can also be interpreted as efficiency targets achievable in the mid-term. Therefore this approach usually leaves room for appreciation by the regulator (e.g. the use of top-down models as complement). In the long term, when assets need to be renewed, the efficient cost incurred by operators is close to the cost obtained with the yearly approach.
- b. **The historical approach** relies on what was built in the previous years to estimate what should be built for the coming years, e.g. optimise year 2011 taking into account the accumulated demand from the previous years. Like the yearly approach, the historical approach can also include a forward looking view. This method closely reflects the history of the deployments, corrected for potential inefficiencies and is therefore usually used to set the tariff at the calculated cost without room for appreciation. Contrary to the yearly approach, it is a lot more complex to implement and depends heavily on the availability and accuracy of extensive detailed historical data.

141. Nevertheless, in cases where service and/or traffic demand is increasing each year at a constant growth rate, these two approaches give the same results when economic depreciation (such as tilted annuities) is used as opposed to accounting depreciation (such as straight line depreciation). However when the quantity of equipment required is equal or lower than that of the previous year, tilted annuities differ between the two dimensioning approaches.

142. Both yearly and historical approaches have been chosen by other NRAs (refer to Annex C –International regulatory approaches on methodological issues). The Authority intends to use the yearly optimisation approach in the development of its bottom-up cost models. This approach will ensure that models are more flexible and better adapted to sensitivity analysis. It also better reflects the costs incurred by a new market entrant in Bahrain and therefore gives better 'build or buy' signals. Moreover, as Bahrain is still a growing market, the choice of a yearly approach would lead to similar results as with the historical approach but without the added complexity and the significant amount of data to be

## Position Paper

Development, implementation and use of fixed and mobile bottom-up network cost models

collected from operators, thus ensuring easily workable models for both the Authority and the relevant operators. In any case, the model would be flexible enough to have a different traffic input for the dimensioning of the traffic (for example, using a traffic in the past that was higher than today) and for the calculation of unit cost (for which the current traffic must be used). This will enable the Authority to carry out sensitivity analysis. However, this would only be achievable if operators provide sufficient historical data on traffic.

**Key message 12:** The Authority will use the 'yearly approach' to optimise the dimensioning of the network. However, the model will be flexible enough to have a different traffic input for the dimensioning of the network and for the calculation of unit cost in to enable sensitivity analysis.

### Services to be modelled

143. While a model is built to calculate the cost of certain (wholesale/retail) services produced by a network, all (other) services provided by this network must be taken into account to determine the level of investment required to support the demand and to appropriately allocate cost between services. It is necessary to do so to ensure that the network is appropriately dimensioned.

144. This being said, it is not necessary to model services that require specific assets and that are not consuming network capacity, such as e-mail secure services, hosting services, etc.

145. The main services that will be considered include:

## Position Paper

### Development, implementation and use of fixed and mobile bottom-up network cost models

**Table 4: Retail and wholesale services to be modelled<sup>56</sup>**

Fixed network		
Access services		
PSTN/ISDN line access	Asymmetric Digital Subscriber Line ('ADSL') broadband access	Wholesale Digital Subscriber Line ('WDSL') service
Bitstream service (Copper)	Unbundled Metallic Path Line ('UMPL') [also called Local Loop Unbundling ('LLU')]	Co-location space at the service node (at the MDF or in a shelter)
FTTH broadband access	Bitstream service (Fibre)	Wholesale FTTH broadband access service
Duct rental	Dark fibre	Wavelength fibre access
Leased lines		
Local leased circuits for retail (Business)	IP-VPN	LAN Connect (managed traffic)
Local leased circuits for OLO ('CAT/LLCO') including backhaul	Wholesale MPLS based leased line service.	
In-Span Interconnect link service ('ISI')	Customer Sited Interconnect link service ('CSI')	Signalling link service (for ISI/CSI)
Interconnection (cost per unit)		
PSTN/VoIP call termination service from mobile line	PSTN/VoIP call termination service from fixed line	PSTN/VoIP call transit service
International inbound calls to Batelco PSTN/VoIP line		
Voice call (cost per unit)		
PSTN/VoIP voice on-net	PSTN voice/VoIP off-net to mobile	PSTN voice/VoIP off-net to fixed
PSTN/VoIP voice off-net to international	PSTN/VoIP call to voice mail	
Other		
PSTN/VoIP voice freephone origination service	Conveyance of emergency call from PSTN/VoIP	Inter-operator transit access service
Carrier selection and pre-selection services	Video and TV unicast services	Multicast services

<sup>56</sup> Additional services could be included if they represent significant traffic. These include: Speaking clock service, National collect call service, Inbound international collect call access service, International operator assisted call service.

## Position Paper

Development, implementation and use of fixed and mobile bottom-up network cost models

Mobile network		
Voice call (cost per unit)		
Mobile voice on-net	Mobile voice off-net to mobile	Mobile voice off-net to fixed
Mobile voice off-net to international	Mobile call to voice mail	Mobile call to specific services (such as directory assistance and customer services)
SMS (cost per unit)		
MMS (cost per unit)		
Mobile broadband (GPRS data, EDGE data, Release 99/UMTS data, HSDPA data and HSUPA data)		
Internet access	Push email	Video
Interconnection (cost per unit)		
Mobile terminating access service	SMS terminating access service	MMS terminating access service
International inbound calls to Batelco mobile telephones		
Other		
Mobile voice freephone origination service	SMS origination service	MMS origination service
Conveyance of emergency call from mobile		

Source: The Authority

146. If relevant, the fixed models could also be developed to include typical NGN services such as IP-TV and video on demand. If these services are not provided in the future, corresponding volumes could be set at zero.
147. It is important to note that the models do not cover the international network, i.e. international gateway and cables are excluded. However international traffic will be taken into account as appropriate in order to adequately dimension networks.

**Key message 13:** The Authority will model each of the services included in the above table. The list of services modelled may be amended as appropriate.

### Treatment of OPEX

148. The total cost of providing a service includes capital expenditures and operating costs. Thus, the efficient level of network operation and maintenance costs needs to be estimated when building a bottom-up model.
149. The Authority recognises that the direct bottom-up modelling of the operating costs for the proposed network design can be a difficult and extremely time-consuming task. It would require a full review of operators' staff and the development of a resource planning tool. For these reasons, the common practice is to estimate these costs indirectly.

## Position Paper

Development, implementation and use of fixed and mobile bottom-up network cost models

150. The following approaches are typically used to calculate operating costs:<sup>57</sup>

- a. Calculating operating costs based on the operators' actual costs (top-down approach).
- b. Calculating operating costs based on the operators' actual costs (top-down) with efficiency adjustments and removal of irrelevant costs as appropriate. Examples of such adjustments include the following:
  - i. Voluntary early retirements can be considered as inefficient costs and can be removed from the top-down calculation. Such an approach has been followed by NRAs in France and Portugal,<sup>58</sup> in Bahrain in the case of LLU, and also in the electricity sector in the UK.<sup>59</sup>
  - ii. A key driver of access network operating costs is the number of faults in the network. The higher the number of faults, the higher the operating costs will be. As a consequence, top-down operating costs can be flexed to reflect the fact that a new access network tends to have fewer faults than an older network. This approach has, for example, been followed by the Irish NRA (ComReg) in 2009 for the setting of LLU prices.<sup>60</sup>

In the two above cases, the bottom-up model can be called a 'hybrid' model.

- c. Conducting a bottom-up calculation. For example, this can be carried out by:
  - i. using percentages provided by suppliers. Suppliers of electronic equipment (such as mobile transceiver/receivers or MSANs) often provide estimates of the annual operating costs expressed as a percentage of the investment. Based on this approach, ComReg has, for example, considered that the annual operating costs related to DSLAMs are equal to 10% of the investment,<sup>61</sup> or
  - ii. estimating the cost of every task by multiplying the time required to complete the task by the hourly staff cost. This approach has been followed by Batelco for determining the costs of some ancillary services related to LLU.
- d. Conducting a benchmark of the OPEX mark-ups used by regulators in other countries.

151. The Authority's view is that operating costs should be calculated using the operators' actual costs (top-down) with adjustments (approach b) and/or with a bottom-up calculation (approach c) depending on the feasibility (e.g. information available) of both approaches. The direct use of OPEX based on top-down information (approach a) is not consistent with

---

<sup>57</sup> see Annex C –International regulatory approaches on methodological issues for more details.

<sup>58</sup> See ARCEP, Decision No.05-0834. Or see Anacom Determination of ICP-ANACOM regarding prices of the local loop unbundling to enter in force as from 01.01.2006.

<sup>59</sup> See Ofgem "Electricity distribution price control review: final proposals"

<sup>60</sup> See ComReg, Response to Consultation Documents No. 09/39 and 09/62 Local Loop Unbundling ('LLU') and Sub Loop Unbundling ('SLU') Maximum Monthly Rental Charges Document No: 10/10

<sup>61</sup> See ComReg, Wholesale Broadband Access Consultation and draft decision on the appropriate price control

## Position Paper

Development, implementation and use of fixed and mobile bottom-up network cost models

the principle of the bottom-up approach as inefficiencies and irrelevant cost may be included.

152. In case operators' data is unavailable, a benchmark will be conducted (approach d). Even where operator data is available, benchmarked data may be used as a cross-check of the resulting OPEX estimates.

**Key message 14:** The Authority will calculate operating costs using the operators' actual costs (top-down) with adjustments and/or with a bottom-up calculation depending on the feasibility (e.g. information available) of both approaches. The direct use of OPEX based on top-down information is not consistent with the principle of the bottom-up approach as inefficiencies and irrelevant cost may be included. When operator data is unavailable, a benchmark will be conducted. Even when operator data is available, benchmarked data may be used as a cross-check of the resulting OPEX estimates.

## 4.2 Financial issues

153. The calculation of costs also involves a number of steps that are neither technical (such as steps involving engineering rules) nor economic (such as steps involving cost allocation methods) but rather financial. For example, when a level of investment calculated by a bottom-up model needs to be annualised in order to determine unit costs, consideration needs to be given to a number of financial issues.
154. These financial issues are discussed in this section. The first part explains how investments should be depreciated in bottom-up models. The use of asset lives is discussed in the second part. The third part discusses whether working capital should be included in the calculation.
155. In addition to the financial issues that are raised in this section, an important parameter in any cost modelling exercise is the cost of capital. While depreciation refers to the *return of capital* over time, the cost of capital refers to the *return on capital*. When an operator invests in an asset, it must be able to recover the appropriate costs of financing this investment: on the one hand, it supports the cost of equity as measured by the returns that shareholders require for this investment and on the other hand, it supports the cost of debt if the investment is also financed by debt. In regulation, these financial costs are typically recovered through the use of a 'weighted average cost of capital' ('WACC'). The cost of capital reflects the opportunity cost of funds invested in the asset, and is incorporated into the cost modelling by multiplying the WACC by the capital employed or through the application of an annuity formula which combines the calculation of both the return on capital and the depreciation charge. The average cost of capital that applies to both Batelco and Zain is currently set at 9.5% as per the Determination on the Cost of Capital (MCD/11/09/090) dated 3 November 2009.
156. While the cost of capital is an important financial parameter that is used in cost modelling, the estimation of the appropriate cost of capital (or WACC) is beyond the scope of the current modelling exercise. Discussion of the appropriate cost of capital is therefore not included in the following section.

## Position Paper

Development, implementation and use of fixed and mobile bottom-up network cost models

### Depreciation

157. The telecommunications industry is a capital-intensive industry which can require significant investments. An operator investing in a given network asset bears an upfront cost and expects that this asset will generate revenues over its useful life. Throughout its useful life, the value of this asset will decrease because of wear and tear and obsolescence. This loss of asset value throughout its useful life is reflected in the operator's profit and loss accounts as depreciation charges.
158. In accounting, depreciation is defined as "the process of systematically allocating the cost of long-lived (tangible) assets to the periods during which the assets are expected to provide economic benefits".<sup>62</sup> In other words, accounting depreciation consists of distributing over the life of an asset its corresponding investment in a systematic and rational manner.
159. Several depreciation methods can be used. Some, for example, do not take into account price changes (HCA, standard annuities), while others are more 'forward-looking' (tilted annuities, CCA-OCM, CCA-FCM) (See Annex B – Asset depreciation for a detailed exposition of the various depreciation methods). While there are some accounting rules governing the choices of depreciation methods, there are many options available that can be implemented by operators. The choice of a given depreciation method has an impact on operators' profit and loss accounts. Therefore, in countries where operators' profits are taxed (which is not the case in Bahrain), specific depreciation methods can be used to serve specific goals such as tax minimisation.
160. Depreciation methods can be classified into two categories:<sup>63</sup>
- a. Accounting depreciation methods; and
  - b. Economic depreciation methods.
161. Within each category, a distinction can also be made between those that take into account price changes, in other words those that are based on current cost and those that are not.
162. Three main **accounting depreciation methods** are often considered by NRAs using top-down systems:<sup>64</sup>
- a. The HCA depreciation method is the most widespread method used in accounting. It is often implemented with 'straight line' or 'linear' depreciation whereby depreciation charges are simply derived by dividing the investment by the asset life. The issue with this approach is that, when the return on capital employed is included to derive annuities, these annuities do not evolve in a smooth way. In particular, the annuity faced by a late entrant would be very different from the annuity faced by an earlier entrant, even though both entrants require access to the same asset. This could cause significant issues for the development of competition if operators were basing their retail prices on the basis of these annuities since they would support very different costs over time (see Figure 5

---

<sup>62</sup> <http://www.cfainstitute.org/about/investor/cfaglossary/Pages/index.aspx?SelectedLetter=D>. IAS 16 defines depreciation as the "systematic allocation of the depreciable amount of an asset over its useful life".

<sup>63</sup> see Annex B – Asset depreciation for further detail.

<sup>64</sup> See for example ERG COMMON POSITION: Guidelines for implementing the Commission Recommendation C (2005) 3480 on Accounting Separation & Cost Accounting Systems under the regulatory framework for electronic communications

## Position Paper

### Development, implementation and use of fixed and mobile bottom-up network cost models

below). The issue is exacerbated when asset prices evolve over time, which is often the case in telecommunications. This is why the HCA depreciation method is rarely used in bottom-up cost models where the objective is to derive economic cost and not accounting cost.

**Figure 5: Competitor entry after 5 years under HCA depreciation (light: incumbent, dark: competitor)**

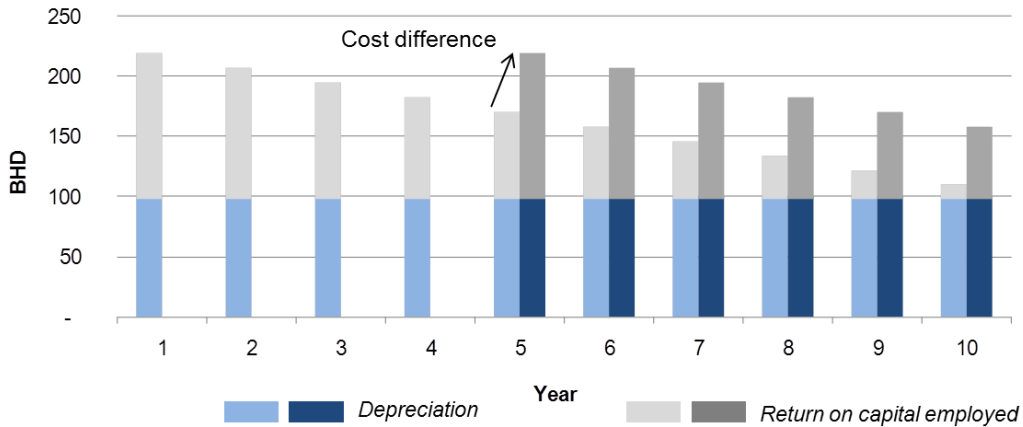

- b. The CCA-OCM method captures changes in asset prices. This is therefore a current cost accounting depreciation method. However, contrary to the HCA method, the CCA-OCM method does not ensure that costs are exactly recovered (See Annex B – Asset depreciation).
- c. Contrary to the CCA-OCM method, the CCA-FCM method ensures that costs are exactly recovered.<sup>65</sup> As with CCA-OCM, this method takes into account changes in asset prices. It is therefore also a current cost accounting depreciation method and this is why it is often preferred by NRAs.<sup>66</sup> But as is the case with HCA, the method does not exactly ensure that the annuities faced by an operator are evolving smoothly where the prices of the asset are changing. This is illustrated in Figure 6, which shows that when the asset needs to be renewed (at the end of year 10 in the example shown), CCA-FCM generates a discontinuity.

<sup>65</sup> This is the approach followed in Batelco's regulatory accounts.

<sup>66</sup> See for example ERG COMMON POSITION: Guidelines for implementing the Commission Recommendation C (2005) 3480 on Accounting Separation & Cost Accounting Systems under the regulatory framework for electronic communications "For example, for the reporting of top-down regulatory accounts, the FCM concept might be preferred because it could better address the concerns of shareholders and potential investors".

## Position Paper

Development, implementation and use of fixed and mobile bottom-up network cost models

Figure 6: Annuities with the CCA-FCM method (dark: return on capital employed – light: depreciation) - Asset renewal (10 years) with increasing prices (5% per annum) under CCA-FCM depreciation

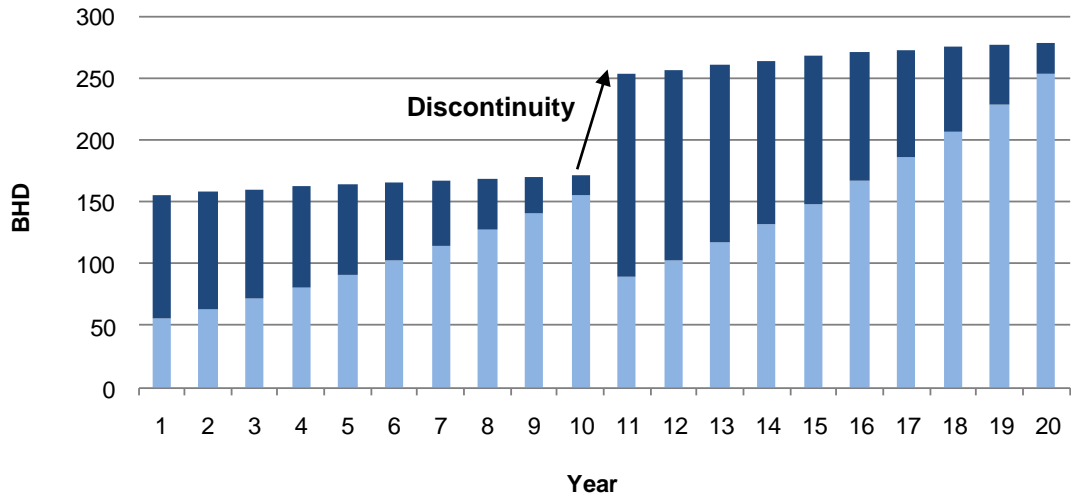

163. None of the accounting-based approaches discussed above can ensure a smooth transition when the asset is replaced. Furthermore, these methods calculate annuities that can lead to significant cost differences for operators investing in the same asset but at a different point in time. They therefore tend to distort economic signals. This is why the economic depreciation concept is often used in regulation, instead of accounting methods.

164. **Economic depreciation** is “defined simply as the period-by-period change in the market value of an asset. The market value of an asset is equal to the present value of the income that the asset is expected to generate over the remainder of its useful life”.<sup>67</sup> In other words, while accounting depreciation allocates an investment for a period of several years, economic depreciation calculates annuities that evolve with expected incomes generated by the asset over the asset’s useful life. For example, for an asset that produces outputs with low demand at the beginning of its life and high demand at the end, all things remaining equal, economic depreciation will tend to derive:

- a. lower annuities at the beginning of the asset life,
- b. higher annuities at the end,
- c. but overall, the annuity per output remains stable.

165. In addition, contrary to historical and current cost accounting depreciations, economic depreciation ensures that two entrants buying the same assets but at different points in time will bear similar annuities. This is a key feature of economic depreciation. As a consequence, economic depreciation is in theory capable of sending perfect ‘build or buy’ signals which is not the case for accounting depreciation.

166. In practice, economic depreciation is difficult to calculate since it requires estimating future demand, future operating costs, future asset prices, terminal values, etc. Contrary to accounting depreciation which uses a specific and objective formula to calculate annuities, economic depreciation is somewhat subjective. Therefore, approximations of economic

<sup>67</sup> Source: Economic Depreciation in Telecommunications Cost Models, Alexis Hardin, Henry Ergas and John Small, A paper prepared for 1999 Industry Economics Conference Regulation, Competition and Industry Structure 12-13 July, Hotel Ibis, Melbourne

## Position Paper

### Development, implementation and use of fixed and mobile bottom-up network cost models

depreciation are often used: standard annuities, tilted annuities and adjusted tilted annuities. These annuities calculate at the same time the sum of the return on capital employed and depreciation.

167. The tilted annuity formula is probably the most widespread one used for regulatory purposes. It incorporates a tilt in its formula which enables the calculation of annuities that evolve in line with asset price changes: if an asset price increases by say 5% per annum, annuities will also increase by 5% per annum, as illustrated in Figure 7. Such a formula sends appropriate 'build or buy' signals to market players. If prices are falling, the operators buying the asset will know that a new entrant in the future will have a lower cost base. As a result, the operator will only invest in the market today if it can recover more of its investment at the beginning of the asset life. It allows regulators to replicate the annual charges that would be faced by an operator in a competitive market.

**Figure 7: Annuities with the tilted annuity method (dark blue: return on capital employed – light blue: depreciation) - Asset renewal under tilted annuity method – Asset price increase of 5% per annum**

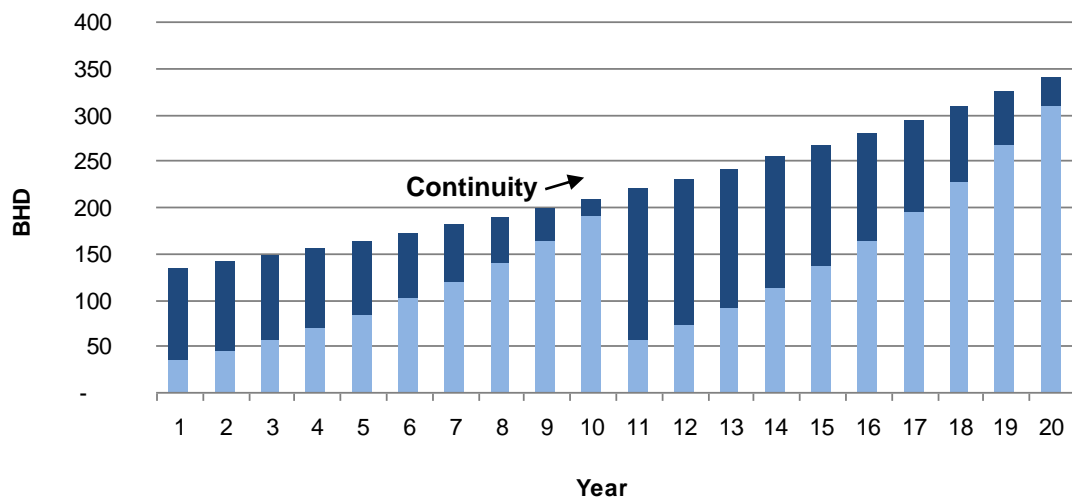

168. A tilted annuity can be calculated on the basis of the following formula:

$$A_t = I \times \frac{(\omega - p) \times (1 + p)^t}{1 - \left(\frac{1 + p}{1 + \omega}\right)^n}$$

where  $\omega$  is the cost of capital,  $I$  the investment,  $t$  the year considered,  $n$  the asset life,  $p$  the tilt (price trend of the asset in the long term) and  $A_t$  the annual cost recovery of year  $t$ .<sup>68</sup>

<sup>68</sup> This annual cost recovery is calculated by assuming that the first annual cost recovery is happening one year after the investment is made. If the time between the moment the first annual cost recovery happens and the investment is paid is one year lower (respectively one year higher), then the annuity should be multiplied by a  $(1 + \omega)^{-1}$  (respectively  $(1 + \omega)$ ).

## Position Paper

### Development, implementation and use of fixed and mobile bottom-up network cost models

169. Even more important, tilted annuities allow a smooth evolution of annual cost despite price changes and despite investment cycles. Indeed, at the end of the useful life of an asset, i.e. when the asset needs to be renewed, the annuities calculated with the tilted annuity method will be similar just before and just after the renewal of the asset (as shown in Figure 7). Therefore, annuities evolve without the discontinuities which are one of the main drawbacks of the HCA, CCA-OCM and CCA-FCM approaches.
170. If the volume of output produced by an asset is stable, then the tilted annuity is a good approximation for economic depreciation. However, the tilted annuity may not be a good proxy for economic depreciation when the volume of output produced by an asset is not stable.<sup>69</sup> This may be the case for new products (which have a logistic curve) or when demand is evolving fast. In this case, an adjusted tilted annuity method can be used. This is likely to be relevant in the case of a FTTH deployment, as the number of FTTH users will likely be low at the beginning but can be expected to be high in the medium to long term. By accounting for changes in the level of outputs produced<sup>70</sup>, adjusted tilted annuities reflect changes in the market value of the asset, which corresponds to the definition of economic depreciation. With such an adjusted tilted annuity, the annuity per unit of output remains stable and follows the evolution of asset prices. This approach requires forecasts on the level of outputs produced.
171. Because NRAs need to send appropriate economic signals to the different market players, they generally use economic depreciation when setting regulated charges.<sup>71</sup> It has been shown above that the use of tilted annuities and adjusted tilted annuities can be a good proxy for economic depreciation. For example, the Norwegian NRA and the Danish NRA have both published a report saying “[i]n a fixed network, circuit-switched traffic levels are generally stable, and so tilted annuities are often chosen as a proxy for economic depreciation”.<sup>72</sup> However, as explained above, tilted annuities need sometimes to be adjusted in order to take into account increasing/declining levels of output. The Authority also intends to take into account projected OPEX trends in the adjusted tilted formula to take into account economies of scale and to prevent discontinuities in the level of unit cost calculated.
172. Consequently, the Authority is of the view that tilted annuities and adjusted tilted annuities should be used in the bottom-up models to depreciate investments.
173. Table 5 summarises the Authority’s view on the appropriateness of the different depreciation methods.

**Table 5: Choice of depreciation methods**

Standard annuity	Tilted annuity	Adjusted tilted annuity
------------------	----------------	-------------------------

<sup>69</sup> See ITST, Report on the LRAIC Model and User Guide Revised Hybrid Model (version 2.5.2), June 2009. See pages 33 and 34 for discussions on standard, tilted annuities and economic depreciation

<sup>70</sup> The adjusted tilted annuity formula can also take into account changes in the level of operating costs over time.

<sup>71</sup> See Annex C – International regulatory approaches on methodological issues.

<sup>72</sup> NPT, Conceptual approach for a LRIC model for wholesale mobile voice call termination Consultation paper for the Norwegian mobile telecoms industry and 27 February 2006 Analysys, LRAIC model of mobile termination: specification consultation paper for industry, 2007

## Position Paper

Development, implementation and use of fixed and mobile bottom-up network cost models

Volume of outputs is stable	Asset prices are stable	✓		
	Asset prices are evolving		✓	
Volume of outputs is not stable	Asset prices are stable			✓
	Asset prices are evolving			✓

Source: the Authority

**Key message 15:** The Authority will implement both tilted annuities and adjusted tilted annuities in the bottom-up cost models. When appropriate, the Authority will account for projected OPEX trends in the adjusted tilted annuity formula.

### Asset lives

174. A distinction is generally made between accounting asset lives and economic asset lives.

175. The International Accounting Standard says that “for all depreciable assets: the depreciable amount (cost less residual value) should be allocated on a systematic basis over the asset’s useful life [IAS 16.50]”.<sup>73</sup> The useful life (or economic life) can be defined as the period of time the asset is being used by the business<sup>74</sup> or the period in which the asset’s revenues exceed its costs.<sup>75</sup> The economic life of an asset cannot be longer than its physical life, but it can be shorter, due to technological obsolescence for example.

176. Accounting asset lives in historical cost accounting (such as statutory accounts) tend to be shorter than economic asset lives. There are many reasons for that, including:

- a. Accounting prudence may require the use of shorter asset lives;<sup>76</sup>
- b. Accounting asset lives may be set first when economic life is unknown and uncertain;<sup>77</sup>

<sup>73</sup> <http://www.iasplus.com/standard/ias16.htm>.

<sup>74</sup> See CIMA Operational Level – Paper F1 Financial Operations, Acorn professional tutors [http://www.acornlive.com/downloads/pdf/F1\\_Revision\\_Summaries.pdf](http://www.acornlive.com/downloads/pdf/F1_Revision_Summaries.pdf).

<sup>75</sup> Report on the LRAIC Model, ITST (Danish NRA), December 2005 <http://en.itst.dk/telecom-internet-regulation/smp-regulation/filarkiv-lraic/lraic-pa-fastnet/LRAIC%20Report%20on%20the%20Hybrid%20Model%20Version%202.3.pdf>.

<sup>76</sup> See John Cubbin, Economics of competition and regulation, background to regulated industries. ([http://cubbin.org.uk/comp\\_and\\_reg2009/week8/Background%20notes%20on%20nationalisation%20and%20privatisation.pdf](http://cubbin.org.uk/comp_and_reg2009/week8/Background%20notes%20on%20nationalisation%20and%20privatisation.pdf))

<sup>77</sup> This has also been observed by Ovum in its report Mobile Termination Rates in Austria A review of RTR’s cost model, A Report for Mobilkom Austria, Orange Austria and T-Mobile Austria March 2009 “*The lives used in the model are accounting lives in that the cost inputs are sourced directly from the operators’ financial systems. Regulators have typically avoided using accounting lives in cost models as they do not reflect the true economic lifetimes of assets. Often accounting lives are developed at a time when the true economic life is uncertain and*

## Position Paper

### Development, implementation and use of fixed and mobile bottom-up network cost models

- c. In countries where company profits are taxed (which is not the case in Bahrain), using short asset lives increases depreciation charges and reduces accounting profit at the beginning, which reduces taxes. As a consequence, companies may prefer shorter asset lives.
177. However one consequence of having asset lives which are shorter than the useful lives of the assets is that companies often use assets that are fully depreciated.
178. The Authority is of the view that economic asset lives should be used. It may therefore be necessary to adjust accounting asset lives used by operators if they do not represent a good proxy for economic lives. Using asset lives that are too short (compared to true economic asset lives) can lead to significant over-recovery of costs in bottom-up models, while the impact is mitigated in top-down models. For example, consider an operator that makes an investment in an asset of BD100, and that the asset has an accounting asset life of 10 years but an economic asset life of 20 years. For simplicity, assume that there is no price trend and no cost of capital. If the accounting asset life is used in the bottom-up model, the annuity will be BD10, whereas it should be BD5. However, if the accounting asset life is used in the top-down model, the annuity will vary between BD10 during the first 10 years and 0 during the 10 last years, which implies that on average the annuity will be BD5 and costs will not be over-recovered. With the bottom-up model, costs are over-recovered if accounting asset lives are shorter than economic asset lives.
179. Further, if the estimated asset life of an asset is too short compared to its economic life, the depreciation charge and resulting price will be too high in the early years of an asset's life and too low in later years. Hence both retail and wholesale consumers would face variability in prices that is a result of an improper choice of asset life rather than any underlying changes in the asset itself or associated market conditions.
180. For regulatory purposes, NRAs need to send appropriate economic signals and this may require amending accounting asset lives in order to reflect economic asset lives. For example:
- a. In 2005, in its 05-0834 decision,<sup>78</sup> the French NRA, ARCEP, decided to use economic asset lives of 40 years for trenches rather than accounting asset lives of 20 years.
  - b. In 2005, the British NRA, Ofcom, decided to increase accounting asset lives of trenches from 25 years to 40 years to reflect their real useful lives for the purposes of setting LLU prices.<sup>79</sup>
  - c. In 2009, the Irish NRA, ComReg, decided to use longer economic asset lives for regulatory purposes.<sup>80</sup> To do so it adjusted the accounting asset lives used by Eircom for a large number of assets.

---

*therefore accountants adopt a prudent approach to assessing the period over which the investment should be written off".*

<sup>78</sup> Décision n° 05-0834 de l'Autorité de régulation des communications électroniques et des postes en date du 15 décembre 2005 définissant la méthode de valorisation des actifs de la boucle locale cuivre ainsi que la méthode de comptabilisation des coûts applicable au dégroupage total.

<sup>79</sup> See Ofcom, Valuing copper access Final statement, August 2005.

<sup>80</sup> See ComReg, Response to Consultation Document No. 09/11: Review of the regulatory asset lives of Eircom Limited Document No:09/65, 11 August 2009. ComReg also published a document from RGL Forensics (final

## Position Paper

Development, implementation and use of fixed and mobile bottom-up network cost models

181. For those reasons, the Authority considers that economic asset lives should be used in the bottom-up cost models. Where accounting asset lives do not provide a good proxy for economic lives, the Authority will make the adjustments that it considers necessary.

**Key message 16:** The Authority will use economic asset lives in the bottom-up cost models.

### Should working capital be included?

182. The activity of a firm either requires or generates cash for everyday operations. The amount of cash required for or generated by day to day operations is defined as working capital. More accurately, working capital can be defined as follows:<sup>81</sup>

*“The net balance of operating uses and sources of funds is called the working capital. If uses of funds exceed sources of funds, the balance is positive and working capital needs to be financed. This is the most frequent case. If negative, it represents a source of funds generated by the business cycle. It is described as “working capital” because the figure reflects the cash required to cover financing shortfalls arising from day-to-day operations.”*

183. Formally, net working capital is equal to current assets (cash and cash equivalent, accounts receivable, inventories and short term investment (shares available for sale)) minus current liabilities (accounts payable and the current portion of long term loans).

184. A cost will generate working capital if there is some delay between the moment the cost is incurred by a company and the moment the revenues aimed at recovering this cost are generated.

185. This working capital, if positive, generates revenues (interests) for the operator and if negative, generates financial costs for the operator. These revenues and costs could or may need to be taken into account in cost models. The cost of the working capital is equal to the capital employed multiplied by the WACC.

186. A telecommunications operator faces different types of costs that can generate working capital:

- a. Non-network costs;
- b. Network CAPEX;
- c. Network OPEX.

187. Working capital generated by non-network costs is due to the financial activities and own decisions of the operator. For example, a firm may keep a substantial amount of cash to finance an expected overseas acquisition. This type of working capital, which is not related to network activities or to the provision of network services but rather to financial activities,

---

report for ComReg of Eircom’s regulatory asset lives 16 February 2009) which discusses how economic asset lives can be assessed.

<sup>81</sup> Corporate Finance, Theory and Practice”, Vernimmen, Le Fur, Quiry, Dallochio and Salvi, 6 February 2009

## Position Paper

### Development, implementation and use of fixed and mobile bottom-up network cost models

is not relevant for setting charges. It would not be appropriate for consumers to pay for the cost generated by activities or decisions which are not related to or necessary for the provision of network services. Thus this type of working capital does not fall within the scope of the network cost modelling exercise.

188. When making network investments, an operator generally begins earning revenues from its asset several months after the investment is completed (the generated cash can then be used to reimburse shareholders and banks). This period which goes from the payment of an asset to its first operating use generates working capital. This period is sometimes referred as 'time to build'. The 'time to build' period can vary significantly from one asset to another. For instance, it depends on whether or not the supplier allows delayed payment (referred as 'payment term'). 'Time to build' periods are usually taken into account in cost models.
189. For network CAPEX, working capital is therefore linked to the period that exists between network investment payment and the beginning of network revenue. The associated cost can be directly taken into account in the annuity formula. If there is a one year delay between the time the investment is completed and the time that revenues are generated, then it is necessary to multiply the annuities by  $(1+WACC)$ . Consequently, to avoid any double counting, the 'network CAPEX working capital' is already covered by the tilted annuity formula.<sup>82</sup>

Figure 8: Network CAPEX and working capital (for illustrative purpose only)

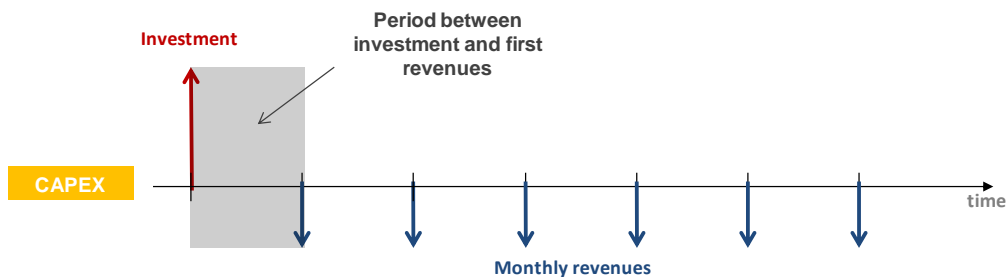

190. For operating costs, there can also be a period of time between staff/suppliers being paid and revenues being earned. Two situations can thus be anticipated:
- Staff/suppliers are paid before revenues are earned: the working capital is negative and the company incurs a cost;
  - Staff/suppliers are paid after revenues are earned: the working capital is positive and the company earns a profit.

---

<sup>82</sup> See Annex B – Asset depreciation.

## Position Paper

### Development, implementation and use of fixed and mobile bottom-up network cost models

Figure 9: Network OPEX and working capital (for illustrative purpose only)

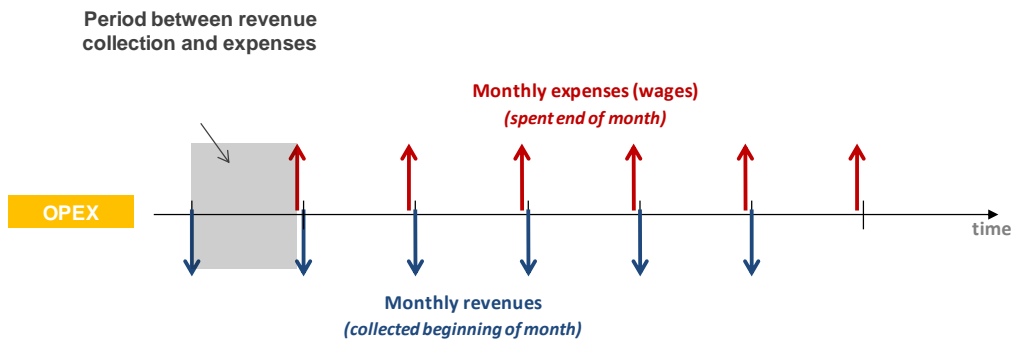

191. Most of the time, staff/suppliers are paid at the end of the month whereas revenues are received at the beginning of the month. As a consequence, network OPEX working capital is considered to be positive or at least not material. It seems therefore reasonable not to take it into account. This is consistent with overseas approaches.
192. In its LLU and sub-loop unbundling (SLU) decision in 2009, ComReg undertook some benchmarking of the treatment of working capital in several international cost models including Australia, France and Sweden. ComReg concluded that in these jurisdictions, the cost of working capital has been set to zero:<sup>83</sup>

*“ComReg also considered a number of models built by other countries and whether working capital was included in them, where publicly available documentation was available in this regard. It was noted that in December 2008 the Australian Competition and Consumer Commission published details on its access and core model which did not include working capital. In France, ARCEP, has consistently excluded the inclusion of working capital unless its calculation was audited. PTS (Sweden) in its 2006 publication of “Hybrid Model User Guide” refers to a calculation for working capital, but states that “based on empirical evidence from the top-down model the cost of working capital has been set to zero.”*

193. Consistent with overseas approaches<sup>84</sup>, the Authority is of the view that working capital should not form part of the BU-LRIC cost model implemented. In any case, in the event that stakeholders were to provide evidence of significant and efficient network OPEX working capital, the Authority would assess the merits of including efficient working capital cost for network OPEX.

**Key message 17:** Working capital which is not related to network activities or to the provision of services will be excluded from the bottom-up cost models.

**Key message 18:** The Authority will exclude working capital costs related to network OPEX from the BU-LRIC models unless operators provide evidence that such costs are material and efficient.

<sup>83</sup> ComReg – Decision 0939

<sup>84</sup> See Annex C – International regulatory approaches .

## Position Paper

Development, implementation and use of fixed and mobile bottom-up network cost models

### 4.3 Charging basis

194. Several charging bases can be used to price a given service. These charging bases include:

- a. BD per minute;
- b. BD per event;
- c. BD per packet;
- d. BD per kbps (capacity based charging) etc.

195. For each service, the charging basis must be selected in order to provide the different stakeholders with the appropriate incentives. It is also preferable for the charging basis to be consistent with the cost drivers of the service. For instance, if internet access was priced on a 'per minute' basis, it would not be in line with cost drivers (capacity). In addition, the charging basis has to be compliant with the applicable legal and regulatory provisions.

196. To enable each service to be priced based on the most appropriate charging basis, the architecture of the bottom-up model will be sufficiently flexible to calculate tariffs based on different charging bases.

197. The default charging basis implemented in the bottom-up cost model will reflect current market practices. However, if the charging basis were to change in the future, conversion factors would be used (for example, using a kbps per minute conversion factor if call termination costs were to be set on a per kbps basis).

### 4.4 Use of gradients for the setting of regulated prices

198. In the telecommunications and electricity markets, it sometimes happens that a single unit produced by the network is sold on the retail or on the wholesale market at different prices, depending on the quality of service or the point in time that the product is used. For example, this is sometimes the case in the telecommunications market for peak call prices or off peak call prices.<sup>85</sup> However, despite prices being different, it may be very difficult to identify real unit cost differences. The price difference does not necessarily reflect cost differences but is rather set in order to encourage customers to consume during 'off-peak' times rather than during 'peak' times (telecommunications networks are dimensioned to meet peak demand, this is reflected in peak prices while off-peak prices enable the operator to generate additional revenues). The mechanism used to set this price difference is called a 'gradient'.

199. When cost differences are difficult to identify between two levels of quality of service or between two moments in time during which the product is used, a gradient can be useful.

200. In telecommunications markets, at least three types of gradients can be found, such as for:

- a. the setting of leased line prices with different speed;
- b. the setting of calling prices with differences between peak and off peak calls; or
- c. the setting of leased line prices for different levels of quality of service.

---

<sup>85</sup> Peak and off-peak pricing is also evident in the electricity market.

## Position Paper

Development, implementation and use of fixed and mobile bottom-up network cost models

201. For leased lines, it can be difficult to identify significant cost differences in the cost per Mbps of, for example, a 10 Mbps leased line and a 1 Gbps leased line. It would therefore follow that the cost-based price of a 1 Gbps leased line should be 100 times higher than the price of a 10 Mbps leased line. However, this could lead to a high price and low demand for the 1 Gbps leased line resulting in it being 'priced out' of the market. This would not allow an efficient use of the network. Consequently, a gradient is often used for leased lines so that, for example, the cost per Mbps of a 1Gbps leased line is lower than the cost per Mbps of a 10 Mbps leased line. As such, overall, prices for the leased line product increase by capacity (measured in Mbps), but the price of each 1Mbps diminishes with the capacity. In other words, the prices increase with the size of the connection, but less than proportionally (i.e. decreasing marginal price per 1Mbps).
202. This gradient can be set by taking into account customer price elasticity. In this case, the use of a gradient can enhance overall consumer welfare as it maximises the capacity purchased by customers.
203. The use of a price gradient can therefore be very useful. However, in such a case - for cost-oriented leased lines - it is very important to ensure that the use of gradients enables operators to overall generate revenues for leased lines that are cost-oriented.

Figure 10: Price of each Mbps unit for the leased line service

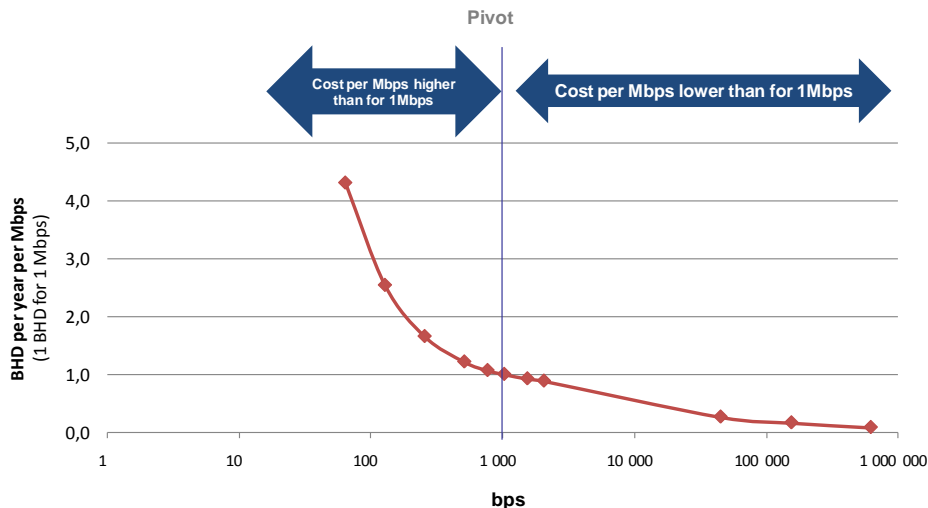

Source: TERA Consultants

204. Another example where gradients are sometimes used is for the distinction between weekly peak call, off-peak call, and weekend call prices. Indeed, it may be very difficult to find obvious cost differences between peak calls, off-peak calls and weekend calls. However, in order to manage/decrease the demand at peak hours and to make sure that the network can support the demand, it can be useful to use a gradient to make calls at peak time more expensive. This can be achieved by taking the call price elasticity into account, and by setting the peak price at a level that will encourage a proportion of users to make calls during off-peak times rather than during peak times.
205. In practice, the setting of such prices is completed in 2 steps. The first step aims at calculating a unit cost for the service on the basis of the cost model. The second step aims at applying a gradient to this unit cost in order to calculate peak, off-peak and weekend prices, ensuring that, overall, costs are recovered. For instance, if the cost model

## Position Paper

Development, implementation and use of fixed and mobile bottom-up network cost models

calculates an average call cost equal to 1BD/min and if the total volume of minutes is distributed between 800 minutes 'peak time' and 200 minutes off-peak, setting an off-peak call price of BD0.50/min would imply a peak call price of BD1.13 /min, as shown below.

**Table 6: Example of the use of a gradient for calling rates**

Item	BD/min	Min
Average cost provided by the bottom-up model	1.0	1,000
Off-peak calls	0.5 *	200
Peak calls	$(1,000 - (0.5 \times 200)) / 800 = 1.13$	800

\* Price of 'off peak' minutes is assumed to be 0.5 BD/min.  
Source: the Authority

206. Gradients may be also used to obtain a set of prices for a single product that is provided with different levels of quality of service, where the different qualities of service are not associated with different costs. For example, the traffic going through a leased line based on the MPLS technology and provided at a specific speed rate may be treated by the network with different types of priorities, which affect technical parameters such as the jitter. These different priority treatments may not involve different costs. Even if there is no significant cost difference between the provision of the service at different levels of quality, it is however important to distinguish the corresponding prices, otherwise, all customers will request the higher level of quality of service. In such a case, differential levels of quality of service will collapse. A gradient can therefore be used to distinguish service prices with different levels of quality of service, providing appropriate incentives for users to demand (or not) a higher quality level (depending on their needs, willingness to pay and their elasticity). As noted above, when designing gradients attention must be paid to ensure that overall revenues calculated on the basis of these prices recover total costs, no more, no less.

**Table 7: Example of the use of a gradient based on the quality of service**

Item	BD/link	Number of leased lines
Average cost provided by the bottom-up model	1.0	1,000
LL with priority 1	0.5 *	200
LL with priority 2	$(1,000 - (0.5 \times 200)) / 800 = 1.13$	800

\* Price of leased lines with priority 1 has been assumed to be 0.5 BD/Mbps.  
Source: the Authority

207. When appropriate, the Authority will use gradients for the setting of regulated prices. However, when using a gradient, it is necessary to ensure that total service revenues (calculated by multiplying the unit prices by associated volumes) equal total service costs (calculated by multiplying volumes by unit costs).

**Key message 19:** When appropriate, the Authority will use gradients for the setting of regulated prices based on bottom-up models.

## Position Paper

Development, implementation and use of fixed and mobile bottom-up network cost models

### 4.5 Period of time covered by the model

208. Bottom-up models calculate unit costs for services depending on the demand at a specific point in time. If forecasts are implemented in a model, a bottom-up model is able to calculate service unit costs over several years. Several options are available in terms of the period of time that should be covered by the model.
209. On the one hand, in an environment where unit asset prices or volumes of demand are evolving rapidly and where there is technological change, the resulting uncertainty may raise challenges in deriving robust unit costs over several years.
210. On the other hand, for NRAs, it is important to give predictability to operators making their investment decisions. In telecommunications, asset lives are generally long, and as a result payback periods for investments are generally long. Consequently, operators need a medium-term view of how regulated tariffs can evolve. A bottom-up model calculating unit costs over several years can be very useful to offer this required visibility. In this context, it is useful to note that over the past years, the annual review of Batelco's reference offer price terms has shown that top-down based costs have difficulties in providing such predictability with accounting costs showing wide variations year on year without changes to underlying economic costs.
211. The Authority is therefore of the view that the bottom-up models it intends to develop in 2011 will be able to calculate service unit costs over several years. Considering that it is particularly difficult to develop meaningful forecasts of demand volumes beyond 4 to 5 years, the Authority is of the view that bottom-up models should calculate unit service costs for the years 2011, 2012, 2013, 2014 and 2015.

**Key message 20:** The Authority will model annual costs over a 4 to 5-year period to give visibility to operators and to enable the setting of regulated charges over several years.

## Position Paper

Development, implementation and use of fixed and mobile bottom-up network cost models

### 5 Model overview

212. Having outlined and discussed the key methodological issues relating to the development and implementation of bottom-up cost models, the Authority provides in this section an overview of the structure and format of the bottom-up models that it intends to develop.
213. Based on international best practice, the Authority intends to develop 3 different bottom-up cost models:
- a. a mobile network cost model. This model will determine mobile network services costs such as interconnection costs, voice call costs, etc., as well as retail services costs through the addition of an expense factor for retail costs.
  - b. a fixed core network cost model. This model will determine the costs of interconnection services, of 'trunk' service for leased lines, carrier selection and pre-selection, etc., as well as retail services costs through the addition of an expense factor for retail costs.
  - c. a fixed access network cost model. This model will determine local loop costs, duct access costs, the costs of the access part of leased lines, the costs of the access part of Bitstream services, collocation and facility sharing, etc., as well as retail services costs through the addition of an expense factor for retail costs.
214. Further cost models could be developed in light of changes that may occur in relation to the scope of regulatory obligations in the future.
215. The costs specific to the wholesale department or equivalent will be added as appropriate to the network cost of access and interconnection services.
216. The reason for having two models for the fixed networks (one for core and one for access) is that access network engineering rules and economics are fundamentally different from those of core networks. For example, access networks depend much more on civil works and much less on active assets than core networks. At the same time the fixed access network and fixed core network cost models will be closely related in terms of inputs such as sharing of ducts, sites, and changes in the traditional boundary between access and core networks as a result of NGN/NGA deployments, etc.
217. The access model will include a module enabling the calculation of collocation costs, so as to determine the one-off charges and ongoing rental charges for the collocation services that are included in Batelco's Reference Offer (except bespoke charges) such as: basic rental, main distribution frame (MDF) blocks and tie cables, power charges, etc. These charges could vary for example according to exchange specificities such as exchange power specification, standby generator provision, false flooring, air-conditioning provision as well as the size of the exchange.
218. Regarding the mobile model, the Authority proposes that 4 versions of the model will be issued: one for each mobile operator – i.e. Batelco, Zain and Viva - and one calculating the cost of a 'generic' operator (see section 4.1 on the generic operator).
219. An overview of the main technical, economic and financial steps necessary to build each model is provided below.

## Position Paper

Development, implementation and use of fixed and mobile bottom-up network cost models

### Mobile network

220. In a mobile network, both access and core network costs are rather traffic-sensitive. As a consequence, there is no need to split the core and access.

Figure 11: Mobile network model structure

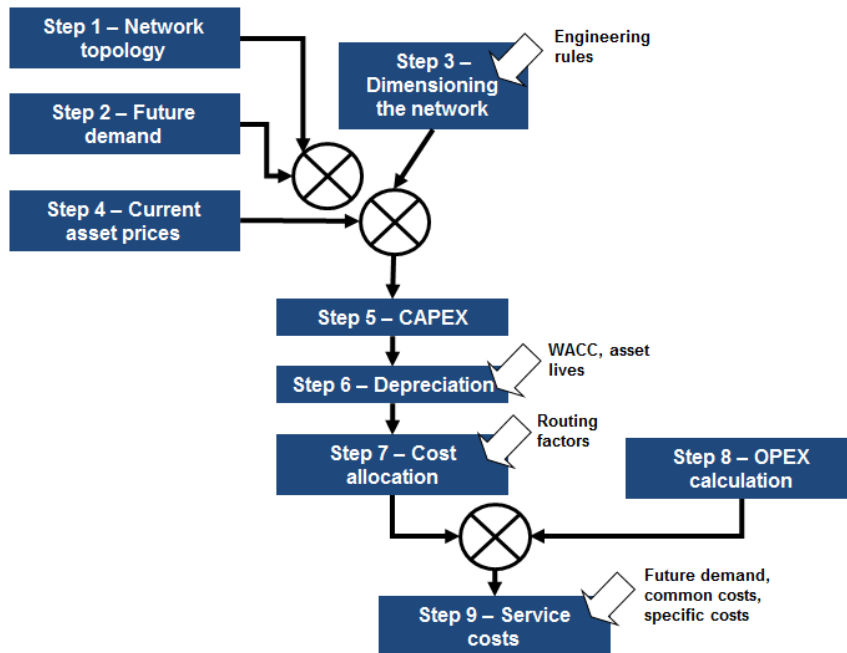

Source: the Authority

221. As described in the above figure, the mobile network model will be built based on a **9-step approach**:

- **Step 1 - Network topology:** The locations of nodes along with required type of equipment (RNC, MSC, servers) will be determined (see section 4.1 on scorched node vs. scorched earth);
- **Step 2 – Future demand:** For each mobile operator and for each service required, forecasts about the future evolution of traffic will be defined. For the ‘generic’ operator, assumptions will be made corresponding to the values for the ‘generic’ operator market share (see section 4.1);
- **Step 3 – Dimensioning the network:** This step consists of determining the type and number of assets based on engineering rules that are required at each level of the network to fulfil the demand (the traffic). The most important part of this step consists of creating the routing table. For each service, the equipment and links that the service uses are determined;
- **Step 4.– Current asset prices:** This step consists of populating the model with the prices of the assets used (see section 6.2);
- **Step 5 – CAPEX calculation:** This step is completed by multiplying the number of assets (step 3) by the price of assets (step 4);

## Position Paper

Development, implementation and use of fixed and mobile bottom-up network cost models

- **Step 6 – Depreciation:** The selected depreciation formula is applied to annualise the investment cost into annual charges. Decisions have to be made regarding asset lives, asset price trends and WACC (see section 4.2);
- **Step 7 – Cost allocation:** Costs are allocated to the different services according to the selected allocation key (routing factors' table, required capacity, etc.) (see section 3.4);
- **Step 8 – Operating costs:** OPEX are added to investments' annual charges. This step can also occur before step 7, depending on the type of OPEX information utilised (see section 4.1). Corporate overhead costs will also be allocated at this stage;
- **Step 9 – Service costs:** The cost model calculates for each service its cost per unit (see section 4.3).

### Fixed access network

222. For the fixed network, access costs are mainly traffic-insensitive. As a consequence, it makes sense to build a dedicated model for the access part.

**Figure 12: Fixed access network model structure**

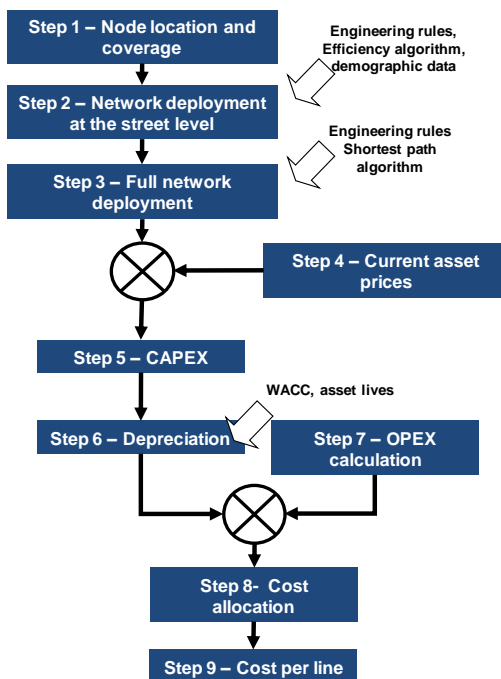

Source: the Authority

223. As described in the above figure, the fixed access network model will be built based on a **9-step approach**:

- **Step 1 – Node location and coverage:** All MDFs/optical node (also referred to as Batelco Service Node) locations are determined (see section 4.1 on scorched node vs. scorched earth);
- **Step 2 – Network deployment at the street's segment level** (see figure below): The model will determine for each segment of road/street, the number of buildings and

## Position Paper

Development, implementation and use of fixed and mobile bottom-up network cost models

dwelling along this segment. The cost related to the deployment of the local loop at the street's segment level will then be derived (see section 6.2);

Figure 13: Step 2 – Network deployment at the street's segment level

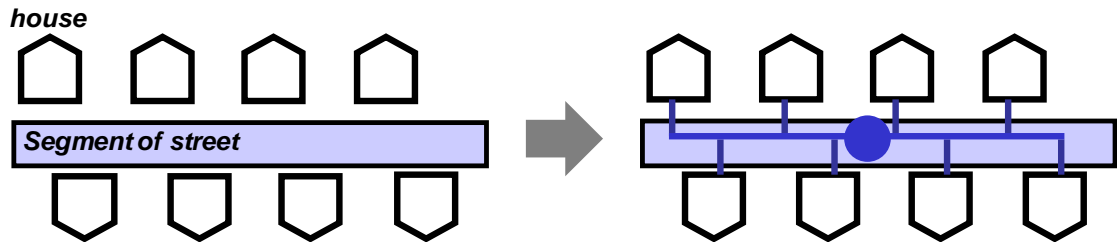

Source: TERA consultants, for illustrative purpose

- **Step 3 – Full network deployment** (see figure below): For each segment of street, and for each MDF/Optical Node, the shortest path between the segment and the relevant MDF/Optical Node will be determined. It will then be possible to determine the type of infrastructure and the size of cable/fibre to be deployed for each segment of street/road. Using the information on the path used by each building to reach the MDF/Optical Nodes, it is possible to determine the capacity and type of infrastructure to be deployed for each segment (see section 6.2);

Figure 14: Step 3 – Full network deployment

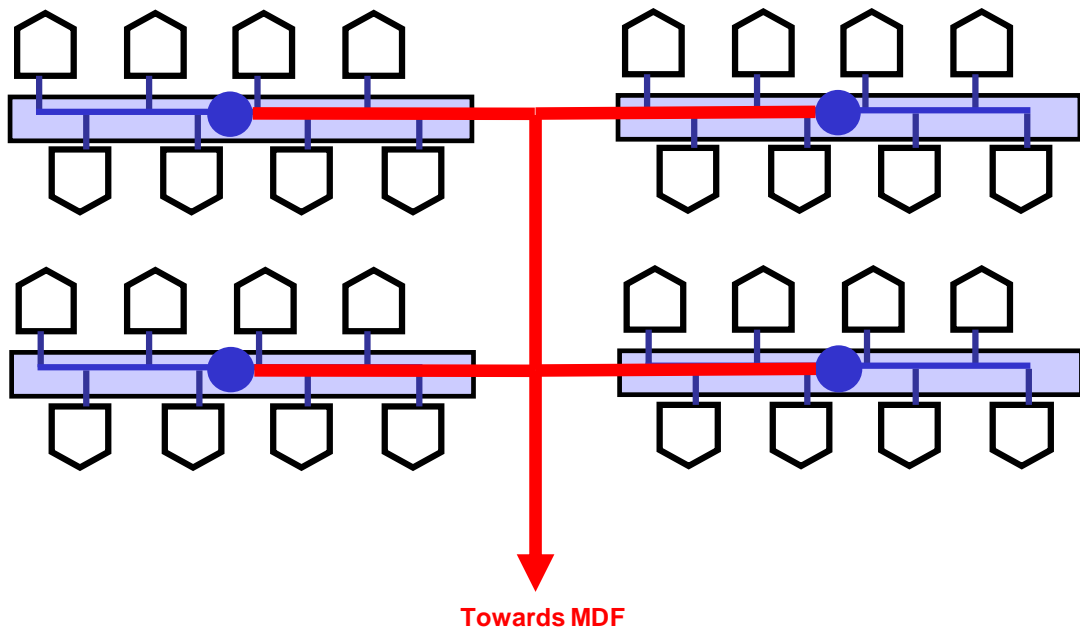

Source: TERA consultants, for illustrative purpose

- **Step 4 – Current asset prices:** The step consists of populating the model with the prices of the assets used (see section 6.2);
- **Step 5 – CAPEX calculation:** This step is completed by multiplying the number of assets (step 3) by the price of assets (step 4);

## Position Paper

Development, implementation and use of fixed and mobile bottom-up network cost models

- **Step 6 – Depreciation:** The selected depreciation formula is applied to annualise the investment cost into annual charges. Decisions have to be made regarding asset lives, asset price trends and WACC (see section 4.2);
- **Step 7 – OPEX:** OPEX are added to investments' annual charges (see section 4.1). Corporate overhead costs will also be allocated at this stage;
- **Step 8 – Cost allocation:** Costs are allocated to the different services according to the selected allocation key (trenches are allocated between fibre and copper for example).
- **Step 9 – Cost per line:** The cost per line (copper or fibre) and per month at the national level or at the MDF/Optical Node level will then be determined.

### Fixed core network

Figure 15 - Fixed core network model structure

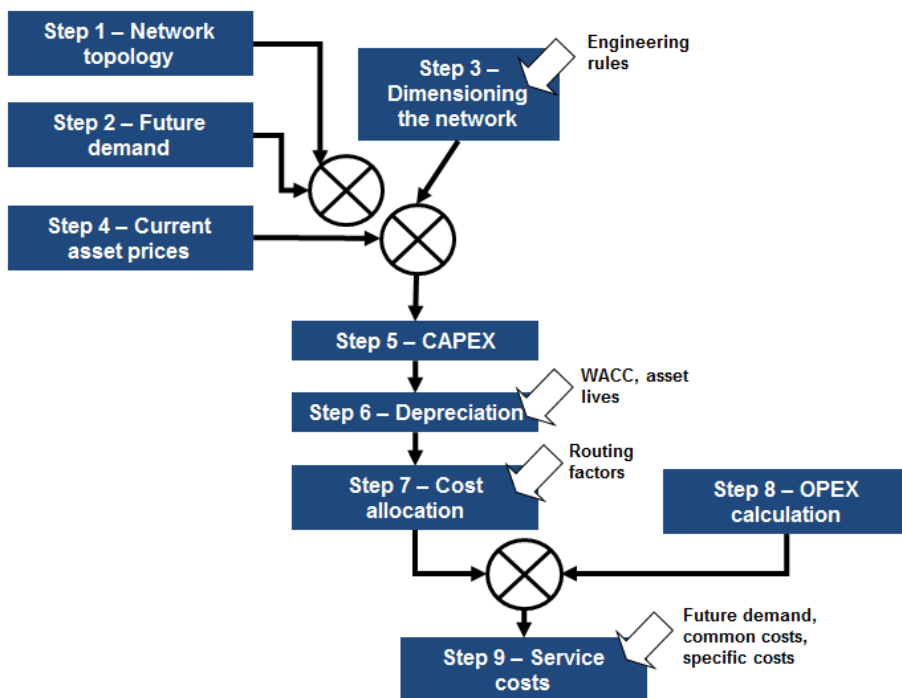

Source: the Authority

224. The fixed core network costs are mainly traffic-sensitive. As a consequence, a dedicated model will be built for the core part of the fixed network. The associated model will be built based on a **9-step approach**:

- **Step 1 - Network topology:** The location of nodes along with the required type of equipment (routers, switches, etc.) will be determined (see section 4.1 on scorched node vs. scorched earth);
- **Step 2 – Future demand:** forecasts regarding the evolution of the traffic over the period under consideration will be developed;
- **Step 3 – Dimensioning the network:** this consists of determining the number of assets that are required at each level of the network to fulfil the demand (the traffic).

## Position Paper

### Development, implementation and use of fixed and mobile bottom-up network cost models

The most important part of this step consists of creating the routing table. For each service, the equipment and links that the service uses is determined;

- **Step 4 – Current asset prices:** The step consists of populating the model with the prices of the assets used (see section 6.2);
- **Step 5 – CAPEX calculation:** This step is completed by multiplying the number of assets (step 3) by the price of assets (step 4);
- **Step 6 – Depreciation:** The selected depreciation formula is applied to annualise investment cost into annual charges. Decisions have to be made regarding asset lives, asset price trends and WACC (see section 4.2);
- **Step 7 – Cost allocation:** Costs are allocated to the different services according to the selected allocation key (required capacity, etc.) (see section 3.4);
- **Step 8 – Operating costs:** OPEX are added to investments' annual charges. This step can also occur before step 7, depending on the type of OPEX information utilised (see section 4.1). Corporate overhead costs will also be allocated at this stage;
- **Step 9 – Service costs:** The cost model calculates for each service its cost per unit (see section 4.3).

### **Model formats**

225. The Authority anticipates that the mobile and the fixed core bottom-up cost models will be developed under Microsoft Excel. The fixed access bottom-up cost model will be developed either under Microsoft Excel or under Microsoft Access, depending on the size of demographic and geographic data which will be used. The models will be transparent and it will be feasible to trace the calculations performed by the models.

226. The Authority intends to include a clear and comprehensive table showing how each of the costs of the services and variants will be produced out of one or a combination of models (e.g. such as leased lines whereby trunks are outputs of the core model and tails are outputs of the access model).

227. Finally, the proposed structure of the bottom-up models is outlined below. These models will consist of several types of spreadsheets:

- a. A control panel spreadsheet from which key spreadsheets can be easily accessed;

## Position Paper

Development, implementation and use of fixed and mobile bottom-up network cost models

Figure 16: Example of control panel

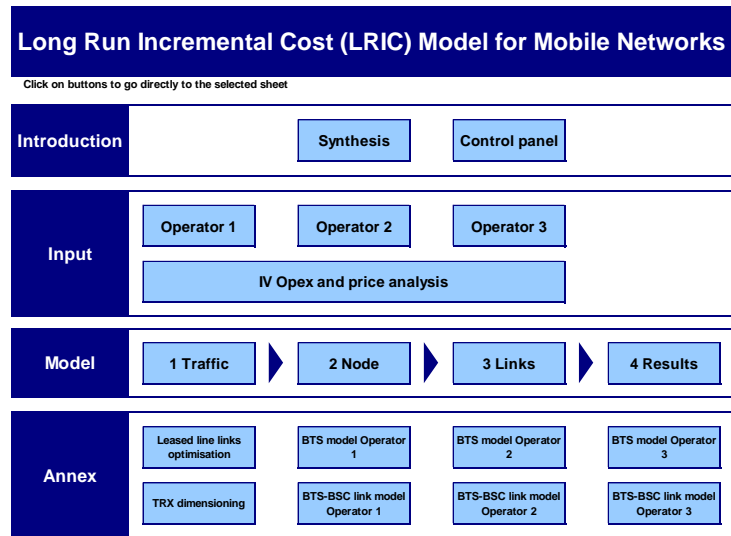

Source: the Authority

- b. Input spreadsheets, which will be organised into two different forms:
  - i. Key input spreadsheets; and
  - ii. Detailed input spreadsheets including several sub-sections such as traffic inputs, unit cost inputs, depreciation inputs, OPEX inputs.
- c. Routing table spreadsheets;
- d. Calculation spreadsheets whose function is to determine the number of assets required for transmission, for switching, for the radio access network, etc., based on the demand (listed in input spreadsheets) and on engineering rules;
- e. Results spreadsheet with different sub-sections for the different services modelled.

## Position Paper

Development, implementation and use of fixed and mobile bottom-up network cost models

### 6 Operational issues

228. The development and implementation of bottom-up cost models involve many steps and interactions with stakeholders. The goal of this section is firstly to identify and discuss these main steps, and secondly to focus on key stages such as the data collection step and the model validation.

#### 6.1 Identification of main steps

229. The Authority anticipates that the development and implementation of the bottom-up models will involve three main steps:

- a. Data collection is a major step to ensure that the modelled networks are representative of local conditions and current engineering rules – this step is further described in section 6.2.
- b. Once data is collected, the second step consists in developing and implementing the cost models. The main steps of cost calculation have been described in previous sections (see section 5), and include:
  - i. CAPEX calculation;
  - ii. OPEX and common cost calculation;
  - iii. Cost allocation to the services;
  - iv. Service cost calculation.
- c. Once a first version of the models has been developed, the Authority intends to test the models to ensure that they are sufficiently robust and realistic. This model validation stage is further described in section 6.3 below.

## Position Paper

Development, implementation and use of fixed and mobile bottom-up network cost models

Figure 17 – Anticipated steps for the development and implementation of the bottom-up cost models

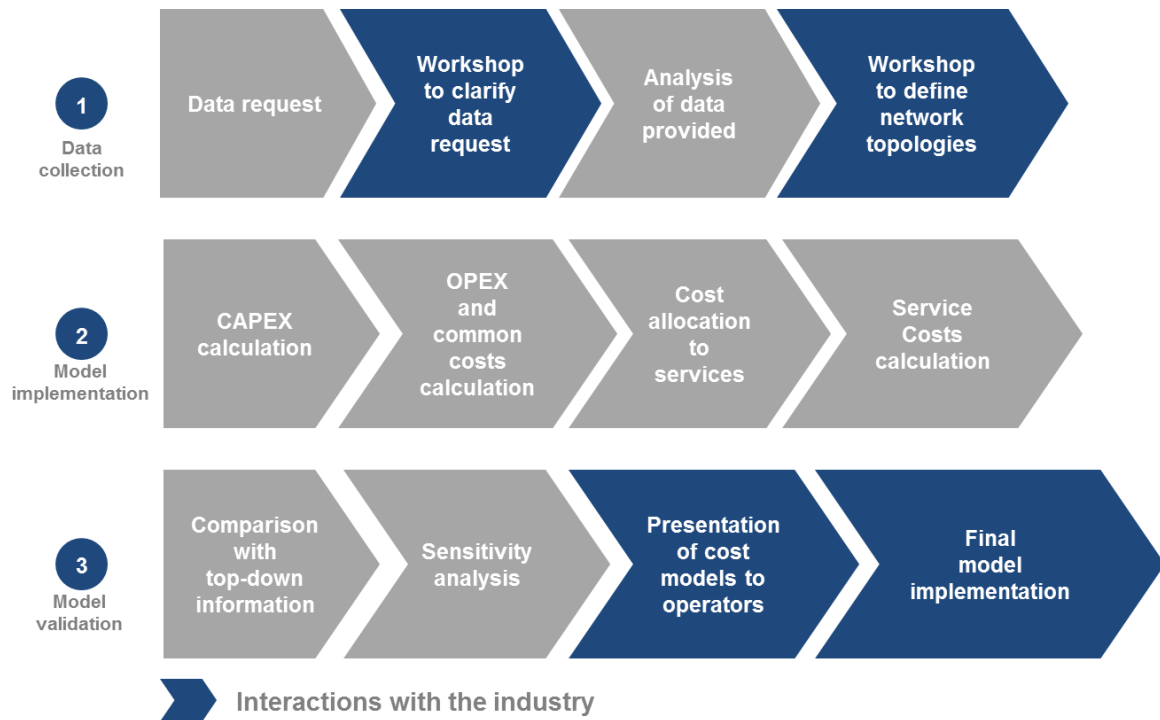

Source: The Authority

230. The Authority will start the data collection phase (step 1) in Q4 of 2011. Model implementation (step 2) is planned to start in Q4 of 2011 and to be completed during Q1 2012. Model validation (step 3) is anticipated to occur in Q1 of 2012 and possibly completed during Q2 of 2012.

**Key message 21:** The Authority anticipates that step 1 (data collection) will occur in Q4 2011; step 2 (model implementation) will occur in Q4 2011 and Q1 2012; and step 3 (model validation) will occur in Q1 and possibly Q2 2012.

## 6.2 Data collection

231. In order to develop the bottom-up cost models, it is necessary to collect data from the industry. This step includes:

- the preparation of a comprehensive data request by the Authority;
- workshops with relevant operators to discuss the data requests;
- visits to the access network to understand local conditions and current engineering rules;
- workshops with relevant operators to define relevant network topologies and structure and engineering rules; and finally

## Position Paper

Development, implementation and use of fixed and mobile bottom-up network cost models

- e. analysis of the data provided by the relevant stakeholders (including in particular Batelco, Zain and Viva).

232. The set of data required will include at least the following:

- a. Data about demand, i.e. traffic data in the past years and associated forecasts: number of on-net minutes, number of off-net minutes, number of minutes for international, number of broadband customers, number of voice customers, etc. This data is a key input to the model since the dimensioning of the modelled network is dependent on demand. In addition, demographic and geographic data will be necessary, especially for the development of the fixed access network model. Indeed, access networks are designed to cover all buildings of a given area by following roads and streets. Therefore, data about the location of buildings, streets and roads is essential to build a realistic access network cost model.
- b. Current unit prices of network assets to calculate the amount of investment required in the modelled network by multiplying the unit prices by the number of assets required to support the demand. For example:
  - i. In the fixed access network: copper cable price by type of copper cable, fibre cable price per type of fibre cable, trench price, pole price, MDF price, street cabinet price, jointing closures prices, etc.
  - ii. In the fixed core network: MSAN prices, ADM prices, fibre prices, MPLS switch prices, etc.
  - iii. In the mobile network: antenna prices, mast prices, transmitter prices, MSC prices, backhaul unit prices, etc.
  - iv. Past unit costs may also be requested to infer price trends used in depreciation formulas (see section 4.2).
- c. Network topologies of the networks, which is very important in a scorched node approach:
  - i. For the fixed core network: number and location of switches, number and location of MSANs, number of servers, layers and structure of the switching network, layers and structure of the transmission network, etc.
  - ii. For the fixed access network: number and location of exchanges, number of poles, kms of trenches, etc.
  - iii. For the mobile network: number and location of base stations, number of MSCs, number of servers, etc.
- d. Network OPEX;
- e. Retail costs;
- f. Costs specific to the wholesale department or equivalent.

233. In addition to this list, the Authority intends to complete four site visits to the access network. This will help understand current engineering rules, specific local constraints and visualise how networks are deployed. Site visits will include different situations:

- i. One site visit in the centre of Manama (copper and fibre deployment);
- ii. One site visit in a business area (copper and fibre deployment);

## Position Paper

Development, implementation and use of fixed and mobile bottom-up network cost models

- iii. One site visit in a less dense area; and
- iv. One site visit in a new development such as Amwaj Islands.

234. Information will be sought pursuant to Article 53 of the Telecommunications Law. The Authority will cross-check and/or complement the data based on benchmarks as appropriate.

235. The development, implementation and validation of bottom-up models is not a perfectly linear process and further information requests may be required as various stages. For instance, to assist the validation stage, it will be required to obtain information from the top-down models.

### 6.3 Outline of the strategy to develop and validate the models

236. The Authority is of the view that the operator-specific cost models should be shared with the relevant operators only, e.g. Batelco for the fixed core and the fixed access network models, and each of the 3 respective mobile operators for the mobile models. The Authority will ensure that no confidential information is provided to other operators.

237. In order to develop, share and validate these models, the Authority anticipates that several interactions with the industry will be necessary. The Authority intends to develop fully transparent and realistic models and for this reason, the involvement of the relevant operators is critical. The Authority anticipates that the following workshops will be required:

- a. Workshop with the relevant operators to define the relevant network topology and the relevant technologies to be modelled;
- b. Workshop with the relevant operators to present the models; and
- c. Workshop with the relevant operators to consider their final remarks.

238. In the validation stage, the Authority will release the models to the relevant operators and will invite operators to provide their views on the operation of the models. The validation step is likely to involve:

## Position Paper

Development, implementation and use of fixed and mobile bottom-up network cost models

- a. The review of the bottom-up models by the relevant operators to ensure that the models capture the relevant assets and costs, and operate in a valid and robust manner;
  - b. A comparison of the bottom-up model outputs with the top-down information and actual network data (e.g. number of base stations, number of kilometres of trenches, number of kilometres of cables, etc.) to identify the extent to which results differ and, if so, the likely drivers of those differences;
  - c. Sensitivity analyses to test the functioning and the sensitivity of the models to key inputs (e.g. traffic at peak hour, allocation methodology, traffic forecast, price trends, etc.);
  - d. The finalisation of the models following completion of the above tasks.
239. The final version of the models will be released to the relevant operators. The generic version of the mobile cost model may be made publicly available subject to the respect of confidential information.

## Position Paper

Development, implementation and use of fixed and mobile bottom-up network cost models

### 7 Use of models

#### 7.1 Use of bottom-up models in Bahrain

240. The Authority intends to develop, implement, and use bottom-up cost models within the existing regulatory framework which includes *inter alia* the use of top-down accounting data to set wholesale and retail tariffs in the context of ex ante regulation. The existing top-down data is also used in the context of ex post investigations for example into allegations of anti-competitive behaviour under Article 65 of the Telecommunications Law.

241. The Authority considers that the models being developed during the course of 2011 will be valuable tools across a broader range of contexts than those in which the existing top-down models are used in Bahrain. This is because the bottom-up models more closely reflect the economic costs associated for example with new investment, and these models also provide greater flexibility and transparency with which cost drivers can be identified. As a result, in addition to complementing the existing top-down models for ex ante regulation and ex post investigations, the bottom-up models are expected to be useful instruments for assessing the costs associated with new investments such as FTTH deployments, as well as for performing sensitivity testing to analyse how costs are impacted by key input variables. The Authority expects that the bottom-up models being developed through the current process will be useful both for the Authority as a regulator and for industry operators contemplating new investments and/or initiatives to minimise costs.

242. The Authority intends to use the bottom-up cost models in various circumstances notably to:

- a. assist in the review and setting of regulated wholesale tariffs;
- b. assist in the review of the retail tariffs;
- c. assist in anti-competitive investigations;
- d. assess the costs associated with new investments such as FTTH deployments;  
and
- e. perform sensitivity analysis (e.g. impact of traffic variations on unit cost).

#### 7.2 Relevant factors to consider when using the models

243. Within a regulatory context, the combination of choices discussed in this Position Paper about the type of model (top-down vs. bottom-up), the valuation of assets (historical costs vs. current costs), and the cost standard (FAC vs. LRIC) could lead in theory to a number of possible cost modelling approaches. In practice, only four approaches tend to be used by regulators to assess operators' costs, namely top-down/historical cost/FAC, top-down/current cost/FAC, top-down/current cost/LRIC, and bottom-up/current cost/LRIC:





- a. As FAC is based on the operator's accounting records, it is implicitly a top-down approach where costs can be either historical (historical cost accounting or HCA) or current (current cost accounting or CCA);

## Position Paper

### Development, implementation and use of fixed and mobile bottom-up network cost models

- b. Though LRIC could theoretically be based on historical costs, LRIC models are based on current cost valuation. For example, the European Commission recently indicated that LRIC is only compatible with current cost valuation: *“Concerning cost standards, the Commission has stated that the long-run incremental cost (LRIC) methodology is consistent with cost orientation. LRIC is normally based on forward-looking cost (FL-LRIC). ‘Forward-looking’ is a term which is used interchangeably with current cost.”*<sup>86</sup> LRIC models can thus be top-down/forward-looking or bottom-up/forward-looking (respectively named TD-LRIC and BU-LRIC as the forward-looking aspect is implicit with the LRIC approach).

**Table 8: Synthesis of available methodologies**

	Historical cost		Current cost	
	FAC	LRIC	FAC	LRIC
↓ Top-Down	HCA		CCA	TD-LRIC
↑ Bottom-Up				BU-LRIC

Source: the Authority

244. In setting wholesale and retail prices, the Authority seeks to ensure that the regulated firm is able to recover its cost, including a return on and of capital. Depending on the context, each of the four methodologies shown in Table 8 has its strengths and weaknesses. There are, however, some general themes that emerge when it comes to calculating the cost of certain (wholesale) services, particularly in relation to the set of regulatory instruments that should be used. These themes are outlined below.

245. HCA is sometimes considered to have some limitations when asset prices are changing because the depreciation charges calculated under HCA do not take into account price changes (see Annex B – Asset depreciation). The ERG recognised the potential limitations of HCA in 2005, and that the current cost approach was designed to address the limitations of HCA:<sup>87</sup>

*“Current cost accounting concepts were originally developed to remedy the limitations of historical cost accounting in a world of changing prices either due to inflation or other reasons such as rapid technological change.”*

246. Moreover, the TD-LRIC approach has some shortcomings of its own compared to the BU-LRIC approach. In particular, efficiency adjustments are difficult to implement, and robust forecasting and cost/volume relationships cannot be derived.

247. As explained above, top-down models give estimates of accounting costs which may vary year on year without changes in underlying economic costs. This limitation, coupled with the difficulty of deriving robust CVRs, make the use of top-down models for multi-year price control more challenging.

<sup>86</sup> European Commission, Commission staff working document accompanying the Commission Recommendation on the regulatory treatment of fixed and mobile termination rates in the EU, Explanatory Note, C(2009) 3359 final, SEC(2009) 599, May 2009.

<sup>87</sup> ERG(05)29, ERG Common Position: Guidelines for implementing the Commission Recommendation C (2005) 3480 on Accounting Separation & Cost Accounting Systems under the regulatory framework for electronic communications, 2005, page 10.

## Position Paper

### Development, implementation and use of fixed and mobile bottom-up network cost models

248. Nevertheless, it is common practice to use conjointly bottom-up and top down models. The complementarity between these two types of models is illustrated by the example of Sweden. The Swedish regulator, PTS, has built a bottom-up model whereas the incumbent, Telia, was responsible for developing a top-down model:<sup>88</sup>

*“Telia is responsible for developing a top-down model while PTS is in charge of developing a bottom-up model in co-operation with interested parties from the industry, including Telia. A reconciliation of the two models will be undertaken by PTS and used as the basis for PTS’s development of a hybrid model on which the final price setting will be based.”*

249. There are two key principles that should govern any regulatory decision regarding the relative weighting on bottom-up and top-down models when setting a regulated charge:

- a. First, regulation must ensure the fostering of competition by encouraging the efficient use of the existing networks and that the owner of the network is not charging access or interconnection to its network well above costs (which would lead to an inefficient underutilisation of the network and over-recovery of costs).
- b. Second, regulators must ensure that the approved tariffs must not be set at such a level that they might deter efficient investment in alternative infrastructure. This tension between providing incentives to invest in a new network and incentives to use the existing network can be summed up as providing the right ‘build or buy’ signal.

250. When alternative operators do have the possibility to invest in a new network, a bottom-up approach (based on replacement cost assumptions) provides the right signal to operators since it mimics the costs incurred by a new operator building a new network. As explained above, when regulated tariffs are set on the basis of bottom-up models, it is neutral for alternative operators to buy access to the regulated network or to build an alternative network. An accounting-based approach (HCA, CCA or TD-LRIC) may not be able to do so because costs reflected in accounts tend to differ from the costs borne by new entrants, for example because of asset price changes.

251. This is no less the case when there are enduring bottlenecks in the market, i.e. when new entrants cannot realistically replicate the network of the incumbent. In this case, as alternative operators cannot build their own network and can only buy access to this network to compete with the incumbent in downstream markets, the ‘build or buy’ trade-off is less relevant. In such cases, it may be preferable to place weight on the costs that were actually incurred by the owner of the bottleneck, including the extent to which those access assets have already been recovered by way of depreciation to avoid over or under cost recovery.

252. In the Authority’s view, the development of a bottom-up cost model remains important for those parts of a telecommunications network that are subject to an enduring bottleneck. This is because for those parts of the network, such as the fixed access network, it is critically important to get access terms, including wholesale access tariffs, at the right level, due to the very fact that alternative access networks are unlikely to emerge. The lack of competitive access infrastructure heightens the importance of facilitating efficient *access-based competition* (i.e. *efficient use of the bottleneck infrastructure*), and reliance

---

<sup>88</sup> PTS, Model reference paper, Guidelines for the LRIC bottom-up and top-down models, 2002.

## Position Paper

Development, implementation and use of fixed and mobile bottom-up network cost models

on a single regulatory instrument (such as the existing top-down modelling approach in Bahrain) is not considered by the Authority to be desirable.

253. A similar reasoning can be found in the 2008 decision of the European Court of Justice (ECJ) regarding LLU pricing in Germany that opposed an alternative operator (Arcor) to the incumbent (Deutsche Telekom):
- a. Several questions were raised for the ECJ, and the Advocate General<sup>89</sup> focused its reasoning on the central issue of the case: should assets be valued through a bottom-up approach or through a top-down approach?<sup>90</sup> According to the Advocate General, a bottom-up approach (or replacement approach) has its strengths, and it is justified to use this approach either to take into account the advanced age of the modelled network (that should indeed, in that case, be replaced) or the need to provide the right 'build or buy' signal (which implies that alternative operators can realistically replicate the network of the incumbent). If neither of these justifications applies, then using a bottom-up approach may not be the most appropriate approach. In other words, a bottom-up approach may be preferable when the network is about to be replaced and/or it is necessary to provide the right 'build or buy' signal;
  - b. However, in its final decision, the ECJ only recommended that the regulator *should not rely on a single tool* to calculate costs but should rather have a broad view and analysis of the situation by taking into account differing methodologies:<sup>91</sup>

*"The Court (Fourth Chamber) hereby rules:*

*When applying the principle that rates for unbundled access to the local loop are to be set on the basis of cost-orientation, (...) in order to determine the calculation basis of the costs of the notified operator, the national regulatory authorities have to take account of actual costs, namely costs already paid by the notified operator, and forward looking costs, the latter being based, where relevant, on an estimation of the costs of replacing the network or certain parts thereof.*

*(...)*

*When national regulatory authorities are applying the principle that rates for unbundled access to the local loop are to be set on the basis of cost-orientation, Community law does not preclude them, in the absence of complete and comprehensible accounting documents, from determining the costs on the basis of an analytical bottom-up or top-down cost model."*

254. This is consistent with observations from Europe where countries that have generally chosen the BU-LRIC approach for setting copper local loop access prices are countries that have a significant share of cable or alternative infrastructure competition (such as Ireland, Germany, Austria, Denmark) while other countries tend to use top-down approaches.<sup>92</sup> In other words, it appears that where infrastructure-based competition is

---

<sup>89</sup> Opinion of Advocate General (Poiães Maduro) delivered on 18 July 2007, Case C-55/06, Arcor AG & Co. KG vs. Federal Republic of Germany.

<sup>90</sup> See paragraph §45 of the Advocate General opinion

<sup>91</sup> Judgment of the Court (Fourth Chamber) in Case C-55/06, Arcor AG & Co. KG vs. Bundesrepublik Deutschland, 24 April 2008.

<sup>92</sup> see Annex D – European and Australian benchmark on costing approaches.

## Position Paper

### Development, implementation and use of fixed and mobile bottom-up network cost models

possible or existing, the BU-LRIC approach is preferred while where it is not the case, top-down models are preferred.

255. In summary, bottom-up models are very useful to send 'build or buy' signals and to ensure that there are incentives to build efficient alternative infrastructure. This is why bottom-up cost models are often used to set regulated tariffs in the context of fixed core networks and mobile networks for which alternative infrastructures exist.<sup>93</sup> However, there may be some cases where the emergence of infrastructure-based competition is not possible because the network is not economically replicable (for example, it could be the case for ducts) and where sending appropriate 'build or buy' signals is not required because alternative operators are unlikely to deploy alternative infrastructure. In such cases, the main regulatory objective could be to ensure that the company owning the bottleneck network does not realise excessive profits and does not over-recover cost. In this context top-down models may be more aligned with the regulatory objective. This would result in the efficient use of the existing infrastructure.

### 7.3 Use of the models to set prices

256. The availability of bottom-up models in addition to top-down models will result in more robust decision-making, consistent with the Authority's duties to promote competition and to protect the interests of end-users. At present, both Batelco and Zain have top-down models which will be complemented by the bottom-up models of the Authority. In the context of price setting, the Authority intends to consider the results of its bottom-up models and of the top-down models of regulated operators.

#### Multi-year price control

257. An advantage of using bottom-up cost models in the context of setting regulated prices is the ability of such models to calculate forward-looking costs and hence to determine forward-looking prices. This provides the regulator with the option of taking a medium-term outlook when setting prices, rather than the short-term annual focus that has existed in Bahrain to date.

258. The ability to set key wholesale access prices over a medium-term horizon (of for example 3 years) creates greater certainty and stability for both the access provider and access-based competitors. This enhanced stability is likely to be an important factor for operators when making investment decisions. For example, for competitors that are contemplating an investment in LLU (including investment in exchange-based equipment and potentially in backhaul), certainty around the level of key prices (such as the monthly rental for unbundled local loops and colocation) over a period of years will be more conducive to such investment than if the access prices were to be set on an annual basis.

259. It is common for regulators to set prices over a multi-year time horizon, including through the use of price caps. For example, in March 2009, the ACCC determined the pricing principle and indicative price for the Mobile Terminating Access Service that would apply in Australia for a period of 3 years, from 1 January 2009 to 31 December 2011. Ofcom

---

<sup>93</sup> see Annex D – European and Australian benchmark on costing approaches.

## Position Paper

Development, implementation and use of fixed and mobile bottom-up network cost models

also has typically set MTRs over a medium term horizon<sup>94</sup>, as well as LLU charges through price caps.<sup>95</sup> In Ireland, ComReg follows the same approach for LLU prices with price caps set for a 3-year period<sup>96</sup>.

260. The introduction of prices applicable for multiple years would provide greater visibility and certainty to the regulated firm(s) and the market, incentives for cost minimisation (as the regulated firm(s) will be allowed to keep whatever profit it achieves during the period for which prices are set) and minimise regulatory cost (as regulatory intervention will be more focussed and there will not be a need to prepare an extensive annual RO submission).
261. While prices may be set for multiple years, it may be necessary to accommodate price adjustments in limited circumstances (especially due to exogenous factors such as a significant change in service usage).

### Use of Glide-path

262. A related issue to multi-year price control is the use of glide paths, which may be appropriate to consider in the event that the use of the bottom-up models results in cost-based prices that are significantly different from prevailing rates. This may also be the case when a service that was provided in the past with a given technology is now provided using a more cost effective technology. For that purpose, a glide path can be used to ensure that a smooth transition occurs.
263. According to the ERG<sup>97</sup>, the glide path mechanism refers to successive adjustments over time from the current rates to a target value.
264. The mechanism of a glide path is generally used for mobile and fixed termination rates that are progressively being reduced to the cost-oriented level. This allows operators time to plan for the decreased revenue and offers stability rather than a one-off shock if there is a significant difference between the existing rates and the cost-oriented or benchmarked rates.
265. In the context of cost modelling, there are a number of options available going from the gradual to the immediate:
- a. Glide path from current prices to cost-orientated prices;
  - b. One-off step change then glide path to cost-oriented prices;
  - c. Immediate move to cost-oriented prices.

---

<sup>94</sup> For example, in its 2007 statement, Ofcom concluded that charge controls should apply for a period of 4 years. See Ofcom "Mobile call termination statement", 27 March 2007, paragraph 1.10.

<sup>95</sup> <http://stakeholders.ofcom.org.uk/consultations/openreachframework/statement/>

<sup>96</sup> See ComReg, Decision D01/10, paragraph 1.17 page 6.

<sup>97</sup> ERG (06) 33, p. 73

## Position Paper

### Development, implementation and use of fixed and mobile bottom-up network cost models

Figure 18 –Glide path from current prices to cost-oriented prices

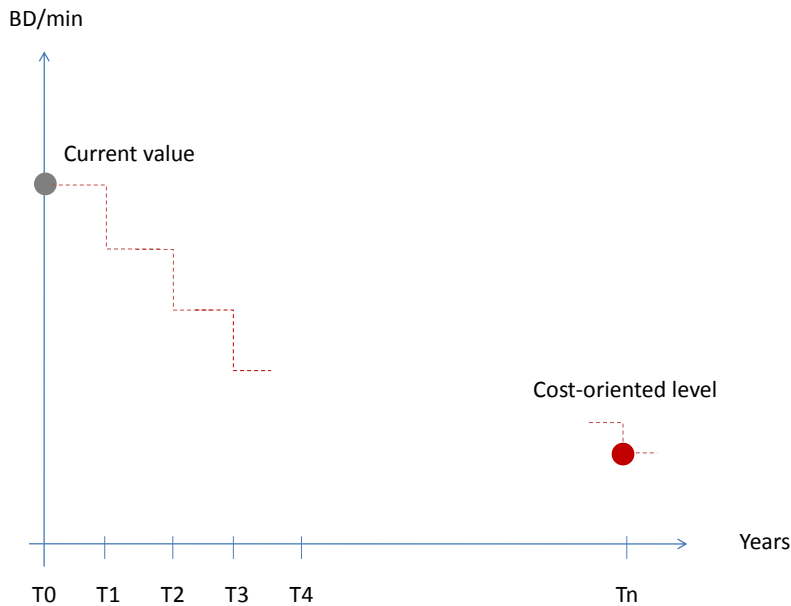

Source: ERG (06) 33, TRA analysis

266. Regarding MTRs, the European Commission has noted that: “a glide path towards an efficient rate should be established without delay as any grace period could remove the incentive to become cost-effective as quickly as possible”.<sup>98</sup> Pursuant to the publication of its Recommendation<sup>99</sup>, many regulatory authorities applied a glide path for the decrease of mobile termination rates.

267. For example, Ofcom has proposed a four-year glide path over which to transition MTRs from existing levels to a maximum average rate calculated using the pure LRIC approach.<sup>100</sup>

268. ComReg has also concluded that a glide path approach is appropriate in order to reduce MTRs:<sup>101</sup>

*“In D11/05 ComReg imposed a price control obligation as provided for by Regulation of the Access Regulations on Vodafone, O2 and Meteor. In that document, ComReg stated its view that the prevailing MTRs of these operators were unlikely to reflect the efficient cost of provision. ComReg also outlined the possibility of using a glide path approach to achieve a more appropriate level.”*

269. The Authority is therefore of the view that in the event that there is a considerable difference between existing rates and bottom-up cost-oriented rates, it may be appropriate to consider the use of a glide path as a transitional mechanism towards the appropriate cost-based level. However, the Authority is also mindful that the use of glide-paths also extends the period during which rates remain above cost and thereby defers the gains in

<sup>98</sup> EC, Recommendation on the Regulatory Treatment of Fixed and Mobile Termination Rates in the EU, p 9.

<sup>99</sup> EC, Recommendation on the Regulatory Treatment of Fixed and Mobile Termination Rates in the EU

<sup>100</sup> Ofcom, Wholesale mobile voice call termination - Market Review, April 2010, p.5

<sup>101</sup> ComReg, Decision09/32, p.3

## Position Paper

Development, implementation and use of fixed and mobile bottom-up network cost models

consumer welfare that arise from cost-based prices. The Authority will take this into account when considering the appropriate duration of any glide-path.

**Key message 22:** The Authority intends to use the bottom-up cost models to set regulated charges over several years.

**Key message 23:** When there is a significant gap between calculated service costs and current charges (due for example to the move from a top-down cost model to a bottom-up cost model), the Authority considers that the use of a glide path may be appropriate to move from existing to appropriate cost-based charges.

## 8 Annex A – Cost allocation

270. Cost allocation is a key topic in the economic literature that has major implications for the results of a cost model.
271. This annex presents the main traditional cost allocation methods. These methods are either part of the proportionality rules family or of the game theory rules family. The implementation of each rule will be explained by way of a common example of a 2-service network (for example, a network supporting both voice and data). This example will be presented in a preliminary section along with key economic concepts that are relevant for the explanation and understanding of cost allocation methods. The advantages and disadvantages of each cost allocation method will be presented in the final section.
272. It is important to note that this annex discusses how common costs should be allocated between different services but does not discuss whether a given service should recover common, direct or joint costs (this latter issue relates to the choice between pure LRIC and traditional LRIC).

### 8.1 Preliminary definitions

#### 8.1.1 Key concepts

273. In order to describe the different cost allocation rules that are generally described in economic theory, several definitions are required:

**Total cost:** the cost of producing all services.

**Fixed cost:** a cost that does not vary when the number of units varies (e.g. ducts and trenches).

**Variable cost:** a cost that varies when the number of units varies (e.g. transmission equipment).

**Stand-alone cost:** the cost of supplying one service without any sharing with other services.<sup>102</sup>

**Incremental cost (fixed + variable):** the cost to provide the service in addition to all the other services.

**Attributable cost:** a cost which can be directly allocated to different services.

**Shared costs:** difference between Total costs and Attributable costs.

**Economy of scope:** economy of cost generated by the sharing of one resource. It is equal to the sum of the stand alone costs of each product minus the total cost of producing jointly all products. It can also be expressed as the total cost minus the sum of the incremental cost of all services.

---

<sup>102</sup> The described methods do not postulate the use of a single technology to provide services in an isolated way or in a common way. The stand alone cost of a service is the cost associated with the most economical technology.

## Position Paper

Development, implementation and use of fixed and mobile bottom-up network cost models

### 8.1.2 Reference example

274. The discussion in this annex is based on the following reference example assumptions: a 2-service network (voice+data) is considered.

- a. The cost of the 2-service network (voice+data) is 100;
- b. The cost of the 1-service network (voice) is 75; and
- c. The cost of the 1-service network (data) is 80.

**Table 9: Total cost, Stand alone and incremental costs of each service of the reference example**



Source: TERA Consultants

The economy of scope is the difference between the sum of the stand-alone cost of each service (75 for voice and 80 for data) and the cost of the 2-service network (100). In this example, the economy of scope is equal to 55.

**Table 10: Calculation of the surplus for the reference example**

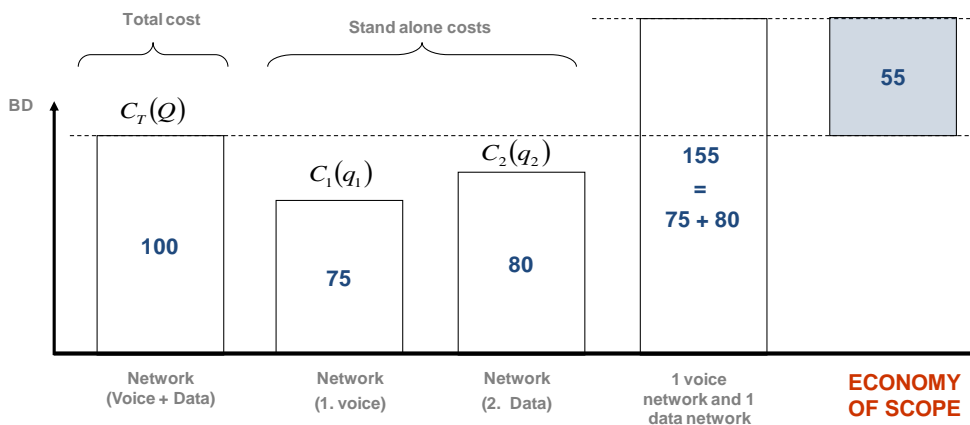

Source: TERA Consultants

The following allocation methods will therefore determine how the common network costs (100) should be allocated between voice and data.

## Position Paper

Development, implementation and use of fixed and mobile bottom-up network cost models

### 8.2 Proportional rules family of cost allocation method

#### 8.2.1 Equidistribution method

##### Description

275. With the equidistribution cost allocation, costs are shared between services in an equal way.

276. This allocation method is more relevant when costs are only or mainly fixed costs. Indeed, for costs that are mainly variable, it is in general easy to find cost drivers, and thus such a method can be used to allocate common costs.

##### Example

Table 11: Cost allocation with equidistribution allocation method

	Voice	Data	Total
Cost Allocation (BD)	50	50	100
%	50 %	50 %	100 %

Source: TERA Consultants

#### 8.2.2 Required capacity method

##### Description

277. Costs are allocated according to the capacities required for each service supported by the network. This rule is applicable to the case where the demand is homogenous (manufacturing the same product for example).

278. In the case of telecommunication networks, costs can be allocated on the basis of the busy hour bandwidth.<sup>103</sup>

##### Example

279. In the reference example, capacity required at busy hour is assumed to be 16% for voice and 84% for data.

---

<sup>103</sup> If the Busy Hour bandwidth (= most relevant cost driver) consumption of the various services differs depending on the network's segments, it is necessary to break up the total cost by the network's segments before carrying out the cost allocation.

## Position Paper

Development, implementation and use of fixed and mobile bottom-up network cost models

**Table 12: Cost allocation with required capacity allocation**

	Voice	Data	Total
Demand at Busy Hour in Mbps	16	84	100
%	16 %	84 %	100 %
Cost Allocation (BD)	16	84	100
%	16 %	84 %	100 %

Source: TERA Consultants

280. With this approach, the allocation rule is consistent with cost drivers (here the busy hour). Due to the capacity required for the voice service, voice only supports a small part of network costs. As a consequence, the share of cost allocated to voice is very low. In the example above, cost allocated to the data service (84) is higher than its stand alone cost (80). This case is possible if there are technologies to supply a service in an isolated way other than the technology used for the multiple services network.

### 8.2.3 Moriarty method

#### Description

281. For each service  $i$ ,  $w_i$  is set as the minimal value between the stand alone cost of service  $i$  ( $c_i$ ) and the sum of its attributable costs ( $Ca_i$ ) and the total shared costs ( $Cs$ ).

$$w_i = \inf(c_i(q_i); \underbrace{Ca_i(Q)}_{\text{Attributable costs}} + \underbrace{Cs(Q)}_{\text{Total shared costs}})$$

282. With the Moriarty allocation method,<sup>104</sup> cost distribution is completed within 4 steps:

- a. First step: each service is allocated its ' $w_i$ '. The most common case is that each service is being allocated its stand alone cost;
- b. Second step: the economy of scope is estimated;
- c. Third step: the economy of scope is allocated to services proportionally to  $w_i$ ;
- d. Fourth step: Calculation of the cost allocation:

$$x_i = w_i + \frac{w_i}{\sum_{j=1}^n w_j} \left( \underbrace{C(Q) - \sum_{j=1}^n w_j}_{\text{Economy of scope}} \right) = \frac{w_i}{\sum_{j=1}^n w_j} C(Q)$$

Total cost of the network

<sup>104</sup> Moriarty, S., (1975), Another concept to Allocating Joint Costs, Accounting Review, 49, 791-195

## Position Paper

Development, implementation and use of fixed and mobile bottom-up network cost models

### Example

283. **Step A** - Allocation to the services is made depending on the stand alone costs (most common case).

	Voice	Data	Total
Stand Alone Costs	75	80	155
%	48 %	52 %	100 %

Source: TERA Consultants

**Step B** - The economy of scope is calculated as the difference between sum of standalone costs (75 for voice, 80 for data) and the total shared network cost (100). The economy of scope is 55 (155-100).

**Step C** - The economy of scope is distributed between services depending on the allocation calculated in step A.

	Voice	Data	Total
Stand Alone Costs	75	80	155
%	48 %	52 %	100 %
Part of the Economy of Scope allocated	$48\% \times 55 = 26,6$	$52\% \times 55 = 28,4$	55 ← Economy of scope

Source: TERA Consultants

**Step D** - Cost allocation.

**Table 13: Cost allocation with Moriarty allocation**

	Voice	Data	Total
Stand Alone Costs	75	80	155
Economy of scope allocated	26,6	28,4	55
	=	=	=
Cost Allocation (BD)	48,4	51,6	100

Source: TERA Consultants

### 8.2.4 Residual benefit method

#### Description

284. The Residual Benefit allocation methodology is also completed within four steps:

- a. First step: Each service is allocated its stand alone cost;
- b. Second step: the economy of scope is estimated;
- c. Third step: allocation of the economy of scope (total cost – sum of the stand alone costs < 0) in proportion to the difference between stand alone cost and incremental cost of each service;

## Position Paper

Development, implementation and use of fixed and mobile bottom-up network cost models

d. Fourth step: Calculation of the cost allocation:

$$x_i = C_i(q_i) - \frac{C_i(q_i) - Cm_i(Q)}{\sum_{j=1}^n (C_j(q_j) - Cm_j(Q))} \left( \sum_{j=1}^n C_j(q_j) - C(Q) \right)$$

Stand Alone cost of service j
Economy of scope
Total cost of the network

Incremental cost of service j

285. With this approach, each service is being allocated its stand alone cost. The generated economy of scope is then redistributed proportionally to residual benefits of each service (stand alone cost minus incremental cost = 'net' benefits for the coalition).

### Example

286. **Step A** - Allocation to services is made on the basis of the difference between Stand Alone Costs and Incremental Costs of each service.

	Voice	Data	Total
Stand Alone Costs	75	80	155
Incremental Costs	20	25	/
	=	=	
Difference	55	55	110
%	50 %	50 %	100 %

Source: TERA Consultants

**Step B** - The economy of scope is calculated as the difference between the sum of stand alone costs (75 for voice, 80 for data) and the total shared network cost (100). The economy of scope is 55 (155-100).

**Step C** - The economy of scope is distributed between services using the allocation key being calculated at step A.

	Voice	Data	Total
%	50 %	50 %	100 %
Part of the Economy of scope allocated	50% x 55 = 27,5	50% x 55 = 27,5	55 ← Economy of scope

Source: TERA Consultants

**Step D** - Cost allocation



## Position Paper

Development, implementation and use of fixed and mobile bottom-up network cost models

293. Shapley allocation guarantees an allocation for each service that is lower than its standalone costs and higher than its incremental costs. Each service has incentives to collaborate and the coalition has incentives to accept each service.

### Example

294. For the 2-service network used in the reference example, 2 sequential entry scenarios are possible: voice comes first or data comes first.

Scenario 1	Scenario 2
<b>1st investment</b> <b>VOICE    75</b>	<b>1st investment</b> <b>DATA    80</b>
<b>2nd investment</b> <b>DATA    25</b>	<b>2nd investment</b> <b>VOICE    20</b>

Source: TERA Consultants

295. The cost allocation is estimated regarding the costs of each service increment in all possible entry scenarios:

	Voice	Data	Total
Scenario 1	75	25	100
	+	+	+
Scenario 2	20	80	100
	▼	▼	
Average	$\frac{1}{2} \times (75+20) = 47.5$	$\frac{1}{2} \times (25+80) = 52.5$	100
%	47.5 %	52.5 %	100%

Source: TERA Consultants

### 8.3.2 Nucleolus method

#### Description

296. The nucleolus method<sup>105</sup> is a method that endeavours to maximise the well-being of the group of users deriving the least benefit from a common project.

297. The cost allocation that maximises the well-being of the group of users is calculated through the use of an algorithm.

298. This algorithm is often quite complex to implement.

#### Example

299. **Step A** - The economy of scope is calculated as the difference between sum of stand alone costs (75 for voice, 80 for data) and the total shared network cost (100). The economy of scope is 55 (155-100).

---

<sup>105</sup> Aumann, R. (Nobel prize winner 2005) & Maschler, M., 1985, Game theoretic analysis of a bankruptcy problem from the Talmud, Journal of Economic Theory, 36, 195-213.

## Position Paper

Development, implementation and use of fixed and mobile bottom-up network cost models

300. **Step B** – In this 2-service configuration<sup>106</sup>, the aim is to maximize the well being of “Voice” and the well being of “Data”. In this case, maximizing the well-being of the group of users deriving the least benefit from the shared network consists in equally sharing the economy of scope ( $55/2=27.5$ ).

	Voice	Data	Total
Stand Alone Costs	75	80	155
Share of the “economy of scope” allocated to service	27,5	27,5	55
Cost Allocation (BD)	47,5	52,5	100

Couple of values that have been maximized

Source: TERA Consultants

## 8.4 Conclusion

### Range of cost allocations in the example case

301. The distribution of costs between the two services varies significantly according to the allocation method selected:

	Voice	Data	
Equal Sharing cost	50	50	}
Required capacity cost	16	84	
Majority	48,4	51,6	
Residual benefits	47,5	52,5	}
Shapley	47,5	52,5	
Nucleolus	47,5	52,5	

« Proportionality » Rules

« Game Theory » Rules

Variation of allocation :      16% - 50%      50% - 84%

<sup>106</sup> When considering more than 2 services, the implementation becomes far more complex. When considering a 3-service configuration, the following steps are required:

- Determine the economy of scope obtained with a 3-service network compared to 3 stand alone networks;
- Find, with an optimization algorithm, the cost allocation (to the services S1, S2 and S3) that maximizes the well-being of the group of users deriving the least benefit from the common project. The groups of users that have to be studied include:
  - S1
  - S2
  - S3
  - S1+S2
  - S1+S3
  - S2+S3

The complexity of this method increases strongly with the number of services considered. For a N-service network, the well being has to be maximized among  $2^N-2$  group of users.

## **Position Paper**

Development, implementation and use of fixed and mobile bottom-up network cost models

Source: TERA Consultants

302. The allocation based on the usage of the fixed network favours the voice service, which is the service requiring the smaller capacity in the network. The Shapley-Shubik and residual benefit methods are the less favourable methods for the voice service.

303. The data service has the highest stand alone cost and busy hour bandwidth requirement. It is thus particularly favoured by the equal-sharing cost allocation method.

### **Pros and cons of each allocation method**

304. Pros and cons of each cost allocation method can be summed up as follows:

## Position Paper

### Development, implementation and use of fixed and mobile bottom-up network cost models

**Table 14: Pros and cons of each cost allocation methodology**

Cost allocation methodology		Pros	Cons
<b>Proportionality rules</b>	<b>Equal sharing</b>	Easy implementation	If there are other technologies which can provide a service in an isolated way, this allocation rule can allocate more costs to a service than its stand alone cost  Is not inducted by relevant cost ('ad hoc' key)
	<b>Required capacity</b>	Easy implementation Follows real cost drivers Often used in telecommunications as many assets are traffic sensitive. This is therefore the 'traditional' method	If there are other technologies which can supply a service in an isolated way, there is a risk that the cost allocation for this service is higher than its stand alone cost
	<b>Moriority</b>	This method guarantees that the cost allocated to a service is lower than its stand alone cost	If the stand alone cost is private information, the entities are encouraged to pretend that these costs are smaller than their real values  Rarely used in telecommunications
	<b>Residual benefits</b>	This method guarantees that the cost allocated to a service is lower than its stand alone cost	Rarely used in telecommunications
<b>Game theory</b>	<b>Shapley-Shubik</b>	This method guarantees that the cost allocated to a service is lower than its stand alone cost  Has been considered by some regulators <sup>107</sup>	Requires to determine not only the stand alone cost for each service, but also the cost of the different combinations
	<b>The nucleolus</b>	This method guarantees that the cost allocated to a service is lower than its stand alone cost	This method is difficult to implement, especially when the number of services is important (corresponds to a 'min-max' optimization)  Rarely used in telecommunications

Source: TERA Consultants

<sup>107</sup> See for example ARCEP, Consultation publique sur les référentiels de coûts et autres éléments pertinents pour la mise en oeuvre des obligations de contrôle tarifaire sur les prestations de terminaison d'appel et de départ d'appel sur les réseaux fixes, 20 May 2008.

## 9 Annex B – Asset depreciation

### *Introduction*

305. The telecommunications industry is a capital-intensive industry which requires significant investments. An operator investing in a given network asset bears a cost and expects that this asset will generate revenues over its useful life in order to recover this cost. Throughout its useful life, the value of this asset will decrease due to wear and tear and obsolescence. This loss of asset value throughout its useful life is reflected in the operator's profit and loss accounts as depreciation charges.
306. In accounting, depreciation is defined as “the process of systematically allocating the cost of long-lived (tangible) assets to the periods during which the assets are expected to provide economic benefits”.<sup>108</sup> In other words, accounting depreciation consists of distributing, over the useful life of an asset, its corresponding investment in a systematic and rational manner.
307. Several accounting depreciation methods can be used. Although choices of depreciation methods are mainly driven by accounting rules, operators are still left with many options. The choice of a given depreciation method has an impact on operators' profit and loss accounts. Therefore, in countries where corporate profits are taxed (which is not the case in Bahrain), specific depreciation methods can be selected to serve specific goals.

### *Historical cost accounting (HCA) depreciation*

308. Under historical cost accounting (HCA) such as in the statutory accounts, the most common depreciation method is the straight-line depreciation.<sup>109</sup> This method is very often used in top-down accounting systems. For example, Batelco uses it in its top-down model. With this method, an equal portion of the initial investment of the asset is allocated to each period in which the asset is used. Consequently, this method is most appropriate when the use of an asset is fairly uniform from year to year. For an asset A requiring an investment  $I = \text{BD } 1,000$  with a useful life  $T = 10$  years, the depreciation charge will equal  $\text{BD } 100$  each year (see Figure 19).

---

<sup>108</sup> <http://www.cfainstitute.org/about/investor/cfaglossary/Pages/index.aspx?SelectedLetter=D>, IAS 16 defines depreciation as the “systematic allocation of the depreciable amount of an asset over its useful life”.

<sup>109</sup> Other methods can be listed: declining-balance depreciation, accelerated depreciation, etc. Paragraph 81 of FR15 notes that “Where the pattern of consumption of an asset's economic benefits is uncertain, a straight-line method of depreciation is usually adopted.” A method of depreciation that is less conservative than a straight-line method would therefore be justifiable only where there is persuasive evidence that it provides an appropriate reflection of the consumption of economic benefits, having regard to factors such as physical deterioration, obsolescence and other factors as set out in paragraph 80 of FR15, and without regard to the time value of money”. Source: Accounting standards board, June 2000, Amendment to FRS 15 “tangible fixed assets” and FRS 10 “goodwill and intangible assets”: interest methods of depreciation

## Position Paper

Development, implementation and use of fixed and mobile bottom-up network cost models

**Figure 19: Depreciation charges under HCA**

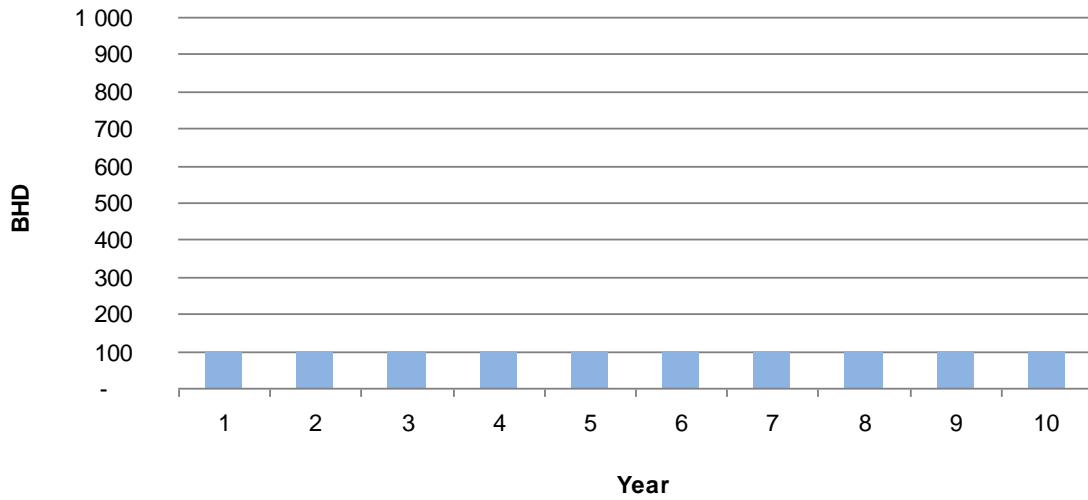

Year	1	2	3	4	5	6	7	8	9	10
Depreciation charge	100	100	100	100	100	100	100	100	100	100

Source: TERA Consultants

309. The net book value of an asset represents the initial cost of the asset minus the cumulative depreciation. Under HCA depreciation, as the depreciation is constant over time, the evolution of the net book value has a straight line decreasing profile (See Figure 20).

**Figure 20: Net book value under HCA**

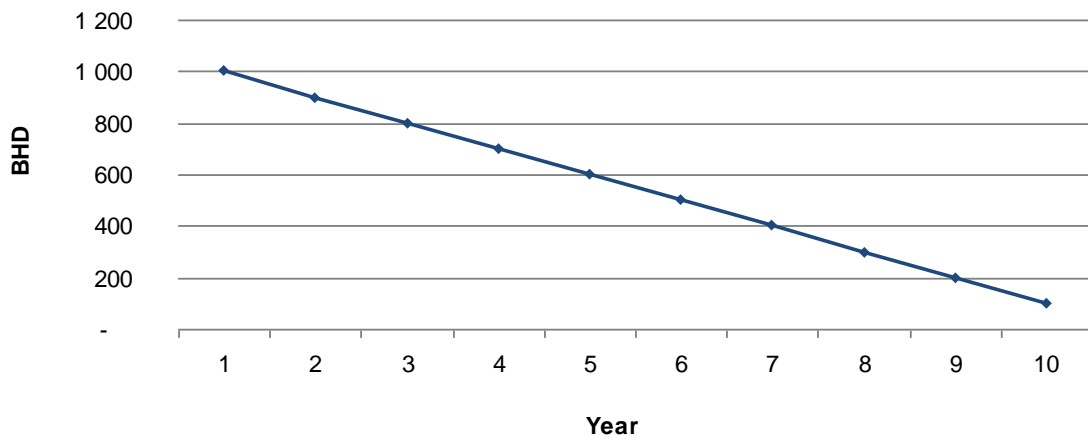

Source: TERA Consultants

310. When an operator invests in an asset, it also supports the financial costs related to this investment: on the one hand, it supports the cost of equity as measured by the returns that shareholders require for this investment and on the other hand, it supports the cost of debt if the investment is also financed by debt. In regulation, these financial costs are called

## Position Paper

Development, implementation and use of fixed and mobile bottom-up network cost models

'cost of capital' or 'weighted average cost of capital' (WACC). The cost of capital reflects the opportunity cost of funds invested in the asset.

311. In general, when National Regulatory Authorities calculate the cost incurred by an operator, they allow a reasonable return on the capital employed. If the cost of capital was not allowed to be recovered, then no investor would invest in regulated assets. As a consequence, in regulation, the annual charge supported by an operator which invests in an asset (this annual charge is called the 'annual cost recovery' in the remaining of the annex) is the sum of the depreciation charge and of the return on capital employed. Using the example above, and assuming that the cost of capital is equal to 10% of the net book value (the return on capital employed is always calculated as a percentage of the mean capital employed which is similar to the net value of the asset), the annual cost recoveries will have the following profile:

**Figure 21: Annual cost recoveries (dark: depreciation charge, light: return on capital employed) under HCA<sup>110</sup>**

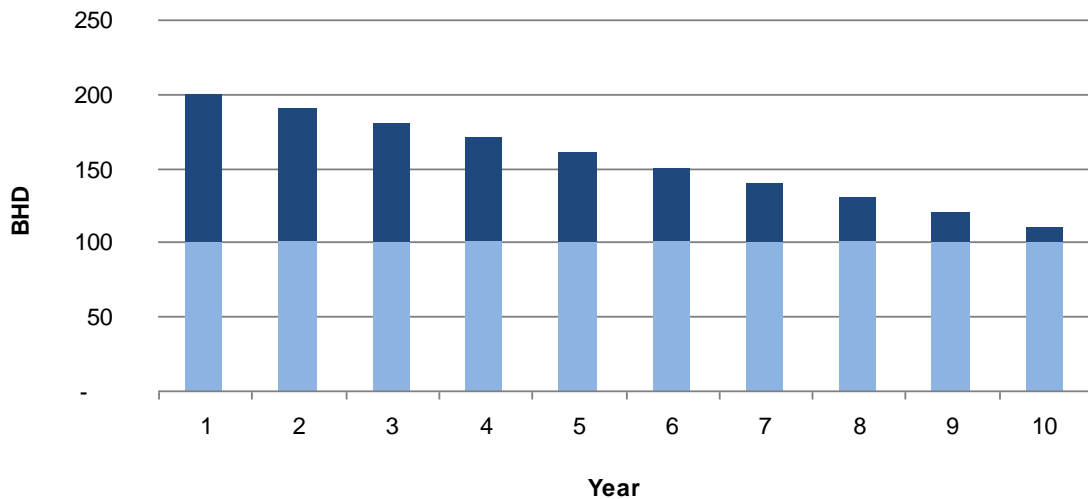

Year	1	2	3	4	5	6	7	8	9	10
Depreciation charge	100	100	100	100	100	100	100	100	100	100
Return on capital employed	100	90	80	70	60	50	40	30	20	10
<b>Annual cost recovery</b>	<b>200</b>	<b>190</b>	<b>180</b>	<b>170</b>	<b>160</b>	<b>150</b>	<b>140</b>	<b>130</b>	<b>120</b>	<b>110</b>
Sum of discounted annual cost recoveries	1,000									

Source: TERA Consultants

312. The sum of discounted annual cost recoveries over the asset's useful life recovers the initial investment, which ensures on the one hand that costs are not over-recovered and that an investor will not be disincentivised to invest in the asset.

$$I = \sum_{i=1}^n \frac{A_i}{(1 + \omega)^i}$$

where  $I$  = Initial investment

<sup>110</sup> For simplicity purposes, it is assumed in this section that the asset begins generating revenues one year after investment is paid. This assumption will be reviewed in the end of this annex.

## Position Paper

Development, implementation and use of fixed and mobile bottom-up network cost models

$A_i$  = Annual cost recovery

$\omega$  = WACC

313. Under the straight-line depreciation method, the annual cost recovery of an asset is decreasing. More generally, with HCA depreciation, the evolution of annual cost recoveries faced by an operator can be erratic. This is particularly the case when the asset needs to be replaced as there will be a significant discontinuity in the annualised capital costs. For example, extending the previous example to allow for replacement of the asset at the end of 10 years, the annual cost recovery faced by an operator will be much lower in the last year of the old asset (year 10) than the annual cost recovery in the first year of the new asset (year 11). This is illustrated in Figure 22, where the discontinuity amounts to 90 (i.e. the annual cost recovery jumps from 110 in year 10, to 200 in year 11). This is furthermore exacerbated when asset prices are increasing, as shown in Figure 23 in the case of asset price inflation of 5% per annum, where the annual cost recovery increases from 110 in year 10, to 326 in year 11, a jump of 216.

**Figure 22: Asset renewal at the same price under HCA**

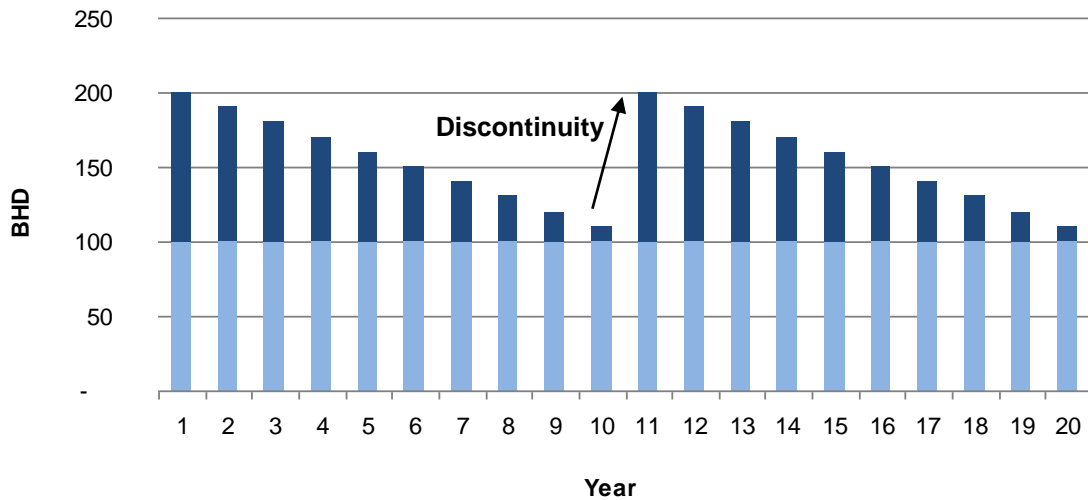

Source: TERA Consultants

**Figure 23: Asset renewal under HCA with asset price increasing (5% per annum)**

**Position Paper**

Development, implementation and use of fixed and mobile bottom-up network cost models

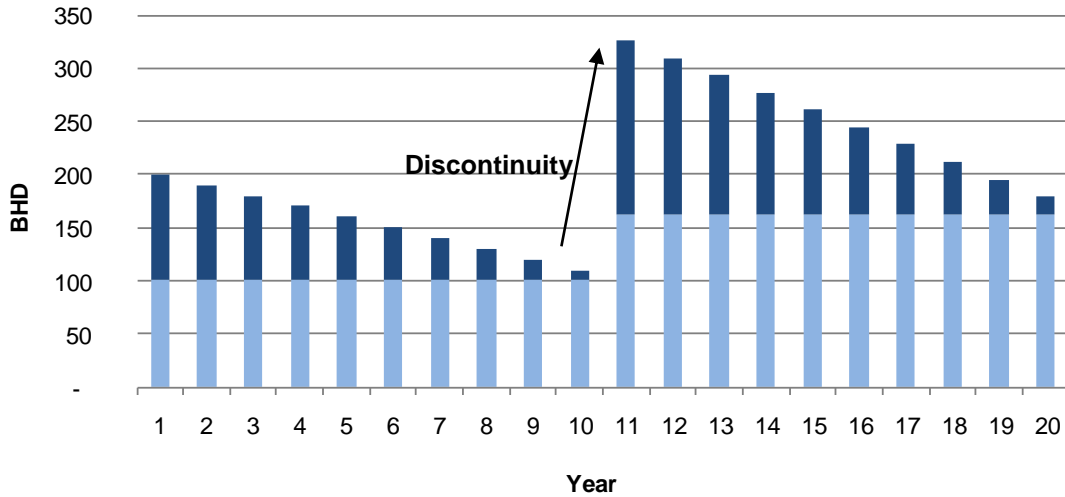

Source: TERA Consultants

314. In addition, the annual cost recovery faced by a competitor entering later would be very different from the annual cost recovery faced by a competitor entering earlier, as shown in Figure 24. This could cause significant issues for the development of the competition if operators were pricing their retail offers according to access prices which themselves derive from HCA-based annual cost recoveries. Under this approach, operators would support different costs over time, even though they operate with the same asset.

**Figure 24: Competitor entry after 5 years under HCA**

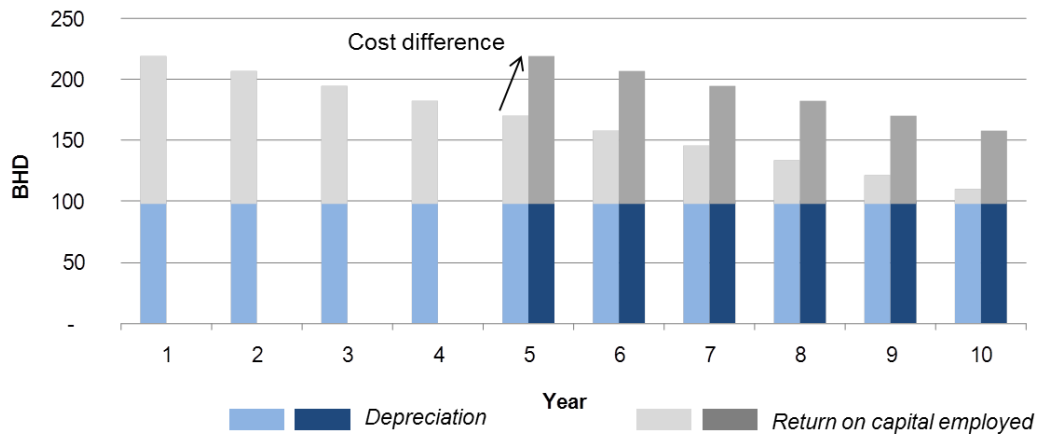

Source: TERA Consultants

315. This is a significant drawback of HCA depreciation in the context of regulation. When setting regulated prices, NRAs need to send adequate price signals which, whenever possible, avoid significant fluctuation from one year to the next. Setting regulated prices on the basis of HCA straight-line depreciation does not send appropriate and relevant economic signals. This is one of the reasons why HCA is not considered as appropriate for regulatory purposes.

**Current cost accounting (CCA) depreciation**

## Position Paper

Development, implementation and use of fixed and mobile bottom-up network cost models

316. Another issue related to HCA depreciation is that it does not provide appropriate economic signals when asset prices are changing, which is often the case in the telecommunications industry. In contrast, as explained in section 3.2, Current Cost Accounting (CCA) is better suited in this specific context. CCA has been developed to remedy the limitations of HCA in a world of changing prices.
317. Under CCA, the same depreciation methods as for HCA can be used (straight line, declining balance, etc.). However, due to the fact that asset prices are reassessed each year under CCA, the ways in which they are applied differ from HCA.
318. There are two main approaches for calculating annual cost recoveries under CCA. Under both approaches using straight-line depreciation, the net book value has the profile described in the following figure (Figure 25).

Figure 25: Net book value under CCA

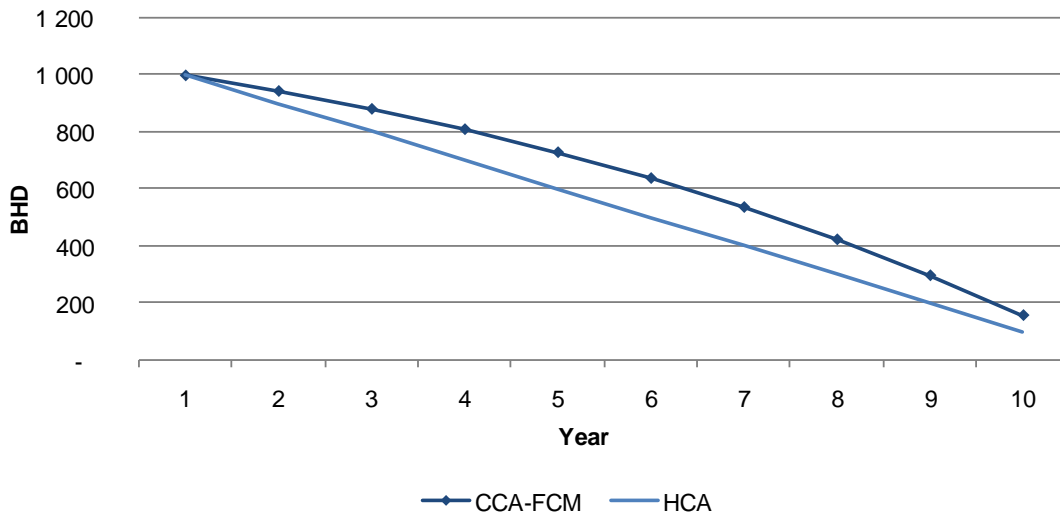

Source: TERA Consultants

319. The first approach, called Operating Capital Maintenance (OCM), consists of calculating annual cost recoveries that are the sum of:
- The HCA depreciation charge (100 in our example);
  - The 'supplementary depreciation' which takes into account the price trend correction of depreciation for the current year;
  - A 'backlog depreciation' which is the difference between:
    - on the one hand the difference between the amount of depreciation of the same asset, with same age, if it had been purchased at today's price and what has already been depreciated for the asset; and
    - on the other hand HCA depreciation with supplementary depreciation; ;
  - The return on capital employed which is still calculated by multiplying the expected rate of return by the net value of the asset. However, under CCA, the net asset value is calculated as the CCA gross book value minus past depreciation.

## Position Paper

Development, implementation and use of fixed and mobile bottom-up network cost models

320. The following figure (Figure 26) calculates the annual cost recoveries of the asset assuming that its market price rises by 5% each year.

**Figure 26: Annual cost recoveries (depreciation charge plus return on capital employed) under CCA-OCM**

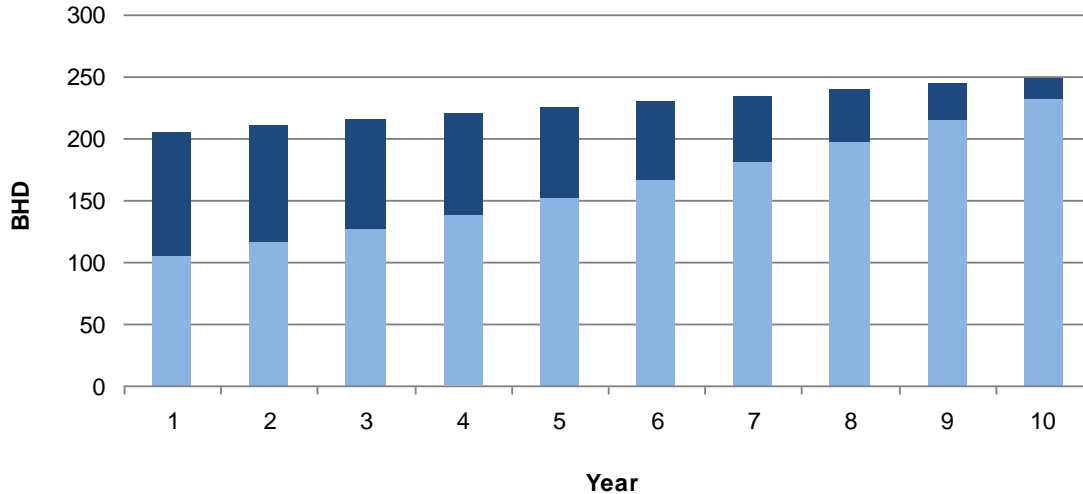

Year	1	2	3	4	5	6	7	8	9	10
HCA depreciation charge	100	100	100	100	100	100	100	100	100	100
Supplementary depreciation	5	10	16	22	28	34	41	48	55	63
Backlog correction	-	5	11	17	24	32	40	49	59	70
<b>Total depreciation charge</b>	<b>105</b>	<b>116</b>	<b>127</b>	<b>139</b>	<b>152</b>	<b>166</b>	<b>181</b>	<b>197</b>	<b>214</b>	<b>233</b>
<b>Return on capital employed</b>	<b>100</b>	<b>95</b>	<b>88</b>	<b>81</b>	<b>73</b>	<b>64</b>	<b>54</b>	<b>42</b>	<b>30</b>	<b>16</b>
<b>Annual cost recovery</b>	<b>205</b>	<b>210</b>	<b>215</b>	<b>220</b>	<b>225</b>	<b>230</b>	<b>235</b>	<b>239</b>	<b>244</b>	<b>248</b>
Sum of discounted annual cost recoveries	1,372									

Source: TERA Consultants

321. The main drawback of the OCM approach is that it does not allow costs to be exactly recovered. Indeed, if prices increase, annual cost recoveries will recover more than the initial investment. If prices decrease, the operator will recover less than the initial investment.

322. Indeed, the discounted sum of annual cost recoveries does not equal the initial investment. As a consequence, this approach is not appropriate for regulatory purposes.

$$I \neq \sum_{i=1}^n \frac{A_i}{(1 + \omega)^i}$$

323. This approach fails to realise that when prices increase, the operators' wealth increases as well (and the reciprocal is also true): in such cases, the OCM approach only generates higher annual cost recoveries. This is what the Financial Capital Maintenance (FCM) approach manages to capture, contrary to the OCM approach. To solve this issue, the FCM approach takes into account the variation of the asset value as a profit or a loss

## Position Paper

Development, implementation and use of fixed and mobile bottom-up network cost models

(called 'holding gain or loss'<sup>111</sup>): when asset prices increase in the market, the value of the asset owned by the operator also increases. This therefore creates an extra profit from the company, which is reflected in the annual cost recoveries of the asset by subtracting the corresponding holding gains (see Figure 27). In the case of a decreasing asset price, annual cost recoveries will be adjusted by subtracting corresponding holding losses.

**Figure 27: Annual cost recoveries (depreciation charges plus return on capital employed) under CCA-FCM**

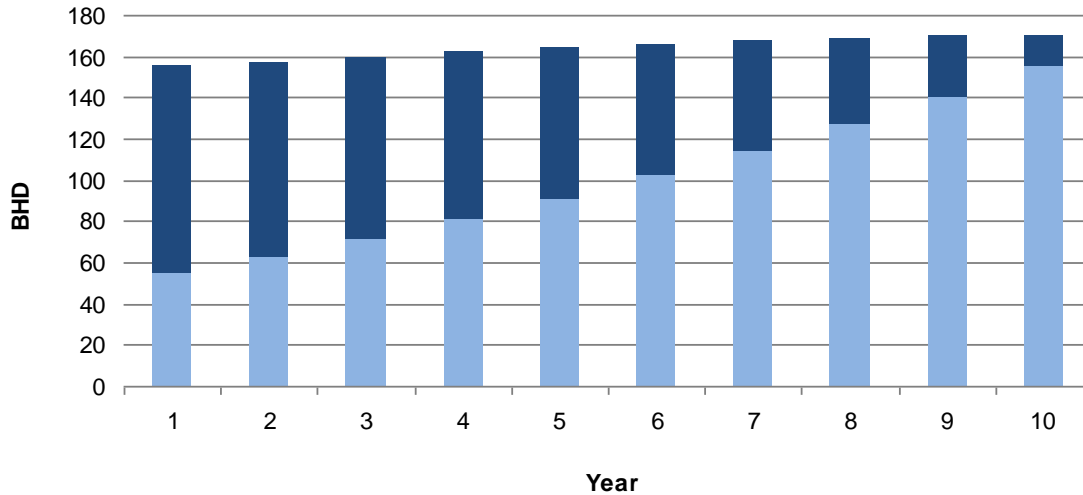

Year	1	2	3	4	5	6	7	8	9	10
HCA depreciation charge	100	100	100	100	100	100	100	100	100	100
Supplementary depreciation	5	10	16	22	28	34	41	48	55	63
Backlog correction	-	5	11	17	24	32	40	49	59	70
Holding gain or loss	50	53	55	58	61	64	67	70	74	78
Total depreciation charge - holding gain or loss	55	63	72	81	91	102	114	127	140	155
Return on capital employed	100	95	88	81	73	64	54	42	30	16
Annual cost recovery	155	158	160	162	164	166	168	169	170	171
Sum of discounted annual cost recoveries	1,000									

Source: TERA Consultants

324. With the FCM approach, the sum of discounted annual cost recoveries equals the initial investment, which ensures on the one hand that costs are not over-recovered and that an investor will not be disincentivised to invest in the asset.

$$I = \sum_{i=1}^n \frac{A_i}{(1 + \omega)^i}$$

325. With both FCM and OCM, annual cost recoveries of an asset tend to decrease throughout its useful life except for the case where asset price is subject to strong increase. Although these approaches reduce the discontinuity gap when assets need to be renewed, this gap can still remain significant (in the example above with prices increasing by 5% per annum, the discontinuity was 126 under HCA and it is now 82 with CCA-FCM).

<sup>111</sup> The holding gain or loss is calculated for year n as the difference between the asset value at year n and the asset value at year n-1.

## Position Paper

Development, implementation and use of fixed and mobile bottom-up network cost models

Figure 28 - Asset renewal with increasing prices (5% per annum) under CCA-FCM depreciation

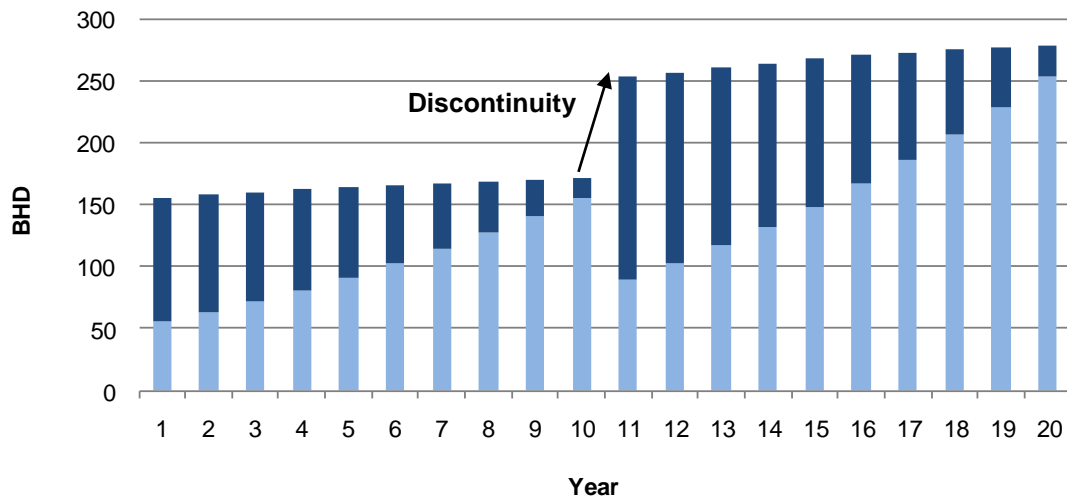

Source: TERA Consultants

### **Economic depreciation**

326. Economic depreciation is “defined simply as the period-by-period change in the market value of an asset. The market value of an asset is equal to the present value of the income that the asset is expected to generate over the remainder of its useful life”.<sup>112</sup> The concept of economic depreciation was first considered by Hotelling (1925) who was dissatisfied with past treatments of depreciation.<sup>113</sup> In other words, while accounting depreciation allocates an investment over several years, economic depreciation calculates annual cost recoveries that evolve with expected incomes generated by the asset over the asset’s useful life. For example, for an asset that produces outputs with low demand at the beginning of its life and high demand at the end, all things remaining equal, economic depreciation derives:

- a. lower annual cost recoveries at the beginning of the asset life;
- b. higher annual cost recoveries at the end;
- c. but overall, the cost recovery per output remains stable.

327. Also, contrary to historical and current cost accounting depreciations, economic depreciation ensures that two competitors entering the market at different times but acquiring access to the same assets will face the same annual cost recoveries (see Figure

<sup>112</sup> Source: Economic Depreciation in Telecommunications Cost Models, Alexis Hardin, Henry Ergas and John Small, A paper prepared for 1999 Industry Economics Conference Regulation, Competition and Industry Structure 12-13 July, Hotel Ibis, Melbourne

<sup>113</sup> Several articles or presentations are publicly available on economic depreciation such as:

- ITU expert-level training on network cost modelling for Asia and Pacific countries, level II, ITU, Valuation Mobile networks Bangkok, Thailand, 15-19 November 2010
- Depreciation, Report by Henry Ergas, August 2008 Concept Economics
- Economic depreciation, NARUC, <http://www.naruc.org/Publications/EconomicDepreciation1997.pdf>
- A note on economic depreciation, Bjørn Hansen, Helene Lie Røhr, 11/2006

## Position Paper

Development, implementation and use of fixed and mobile bottom-up network cost models

24 above). This is a key advantage of economic depreciation over accounting depreciation in the context of price regulation.

328. In practice, economic depreciation can sometimes be difficult to calculate since it requires forecasting future demand, future operating costs, future asset prices, etc. Contrary to accounting depreciation which uses a specific and objective formula to calculate annuities, economic depreciation is somewhat subjective. Therefore, approximations of economic depreciation are often used. Three methods are described below: standard annuity method, tilted annuity method and adjusted tilted annuity method. They allow the exact recovery of the initial investment like CCA-FCM and HCA. Depending on the context, they can be sometimes considered by NRAs to be an approximation for economic depreciation.

### **Standard annuity method**

329. The first method is the **standard annuity method** which is appropriate when asset prices and volumes of outputs of this asset are stable. The standard annuity approach consists of calculating an annual charge  $A$  called annuity, which is identical every year and which respects the following equation:

$$I = \frac{A}{(1 + \omega)} + \frac{A}{(1 + \omega)^2} + \dots + \frac{A}{(1 + \omega)^n}$$

330. Then,  $A$  can be written as follows:<sup>114</sup>

$$A = I \times \frac{\omega}{1 - \left(\frac{1}{1 + \omega}\right)^n}$$

331. Under the standard annuity method, the net book value has the following profile (Figure 29):

---

<sup>114</sup> This formula assumes that the operator begins generating revenues from the asset one year after investment is completed.

**Position Paper**

Development, implementation and use of fixed and mobile bottom-up network cost models

**Figure 29: Net book value under standard annuity method**

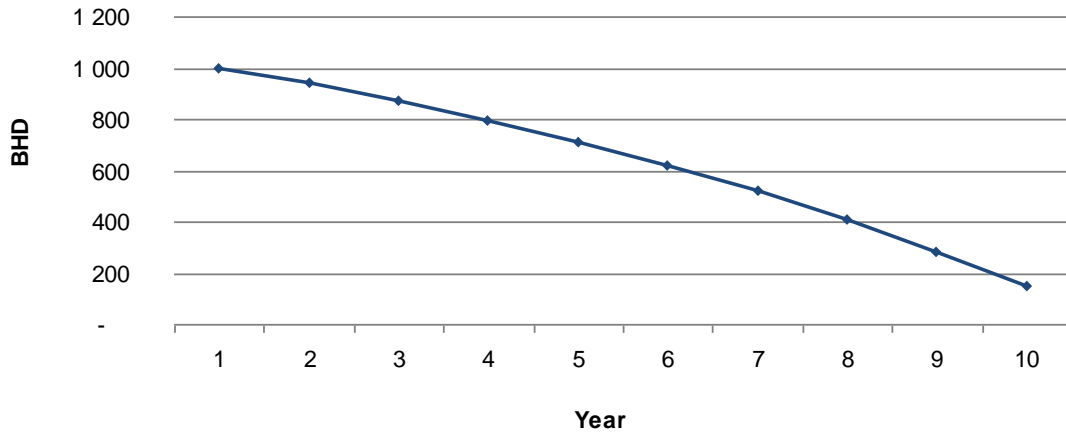

Source: TERA Consultants

332. The standard annuity method is, for example, the one used by banks to calculate annuities paid by households or businesses which require a loan at a given interest rate to realise an investment. The standard annuity approach calculates an increasing depreciation charge and a decreasing return on capital employed in such a way that the annuity remains stable over time. Because standard annuities (sometimes called flat annuities) do not take into account changes in the asset price, they do not reflect the market evolution of the asset value and therefore cannot be considered as economic depreciation. They are rarely used. Like historical cost accounting depreciation, such annuities can create distortions and discontinuities in regulated price evolution when asset prices change over time (see Figure 30).

**Figure 30: Asset renewal at a higher price under standard annuity method**

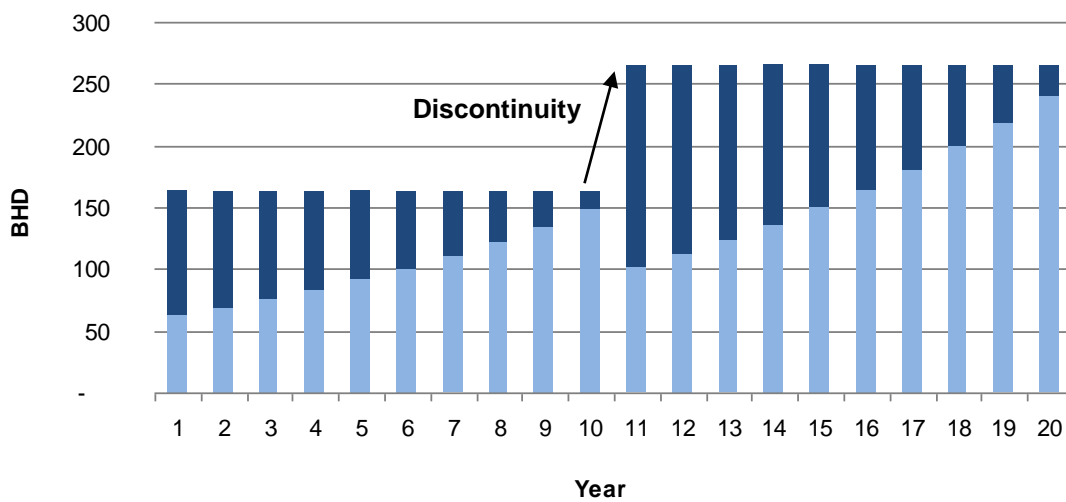

Source: TERA Consultants

## Position Paper

Development, implementation and use of fixed and mobile bottom-up network cost models

### ***Tilted annuity method***

333. In the event that asset prices are expected to change over the life of the asset - which is the case in telecommunications - a tilt can be applied to the standard annuity formula to ensure that annuity (i.e. the annual charge related to an investment) in any period is equal to annuity that a new entrant would seek, having purchased a new asset. This tilt is used to mimic the asset price path that is expected for the asset in the market. As a consequence, contrary to the standard annuity, the annuity in year Y is equal to the annuity in year Y-1, taking into account asset price changes between year Y-1 and year Y. The annuity  $A_1$  of the first year verifies the following equation:

$$I = \frac{A_1}{(1 + \omega)} + \frac{A_1 \times (1 + p)}{(1 + \omega)^2} + \dots + \frac{A_1 \times (1 + p)^{n-1}}{(1 + \omega)^n}$$

334. Which is the same as:

$$I = \frac{A_1}{(1 + \omega)} \left[ 1 + \frac{(1 + p)}{(1 + \omega)} + \dots + \frac{(1 + p)^{n-1}}{(1 + \omega)^{n-1}} \right]$$

With  $p$  being the tilt, which represents the long term price trend observed or expected for this asset

335. Then, annuities can be written as follows:<sup>115</sup>

$$A_t = I \times \frac{(\omega - p)(1 + p)^t}{1 - \left(\frac{1 + p}{1 + \omega}\right)^n}$$

336. This method is called the tilted annuity method. Compared to standard annuities, the recovery of costs is accelerated with a tilted annuity when asset prices decrease (and is deferred when asset prices increase). The comparison between Figure 29 and Figure 31 illustrates this effect.

---

<sup>115</sup> The demonstration of this formula is proposed in the "payment terms" part

## Position Paper

Development, implementation and use of fixed and mobile bottom-up network cost models

**Figure 31: Net book value under tilted annuity method (prices increase)**

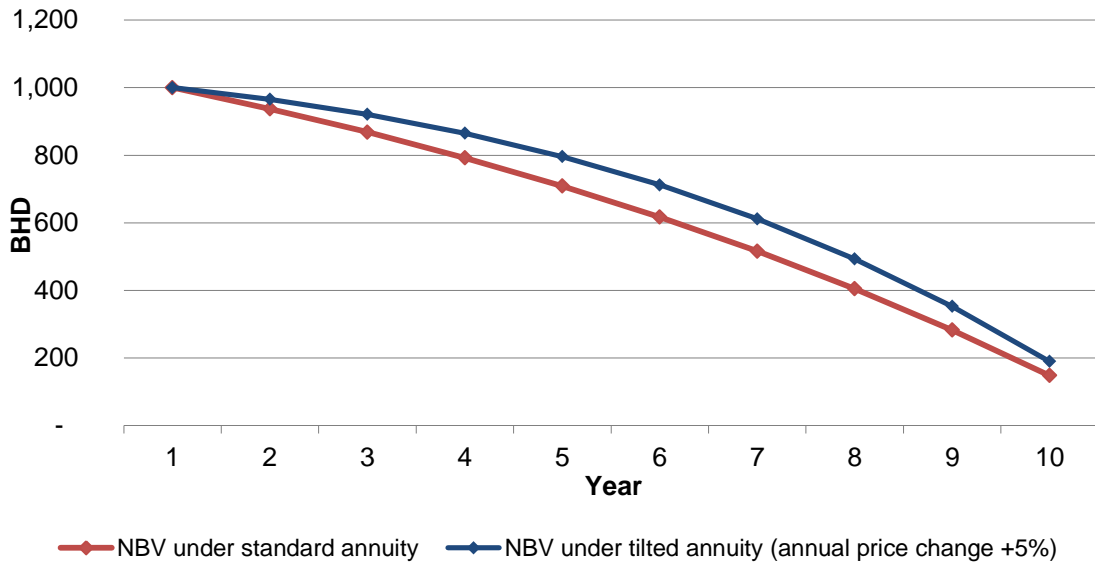

Source: TERA Consultants

337. Under the tilted annuity method, the annuities have the following profile (Figure 32):

**Figure 32: Annuities (depreciation charges plus return on capital employed) under tilted annuity (prices increase)**

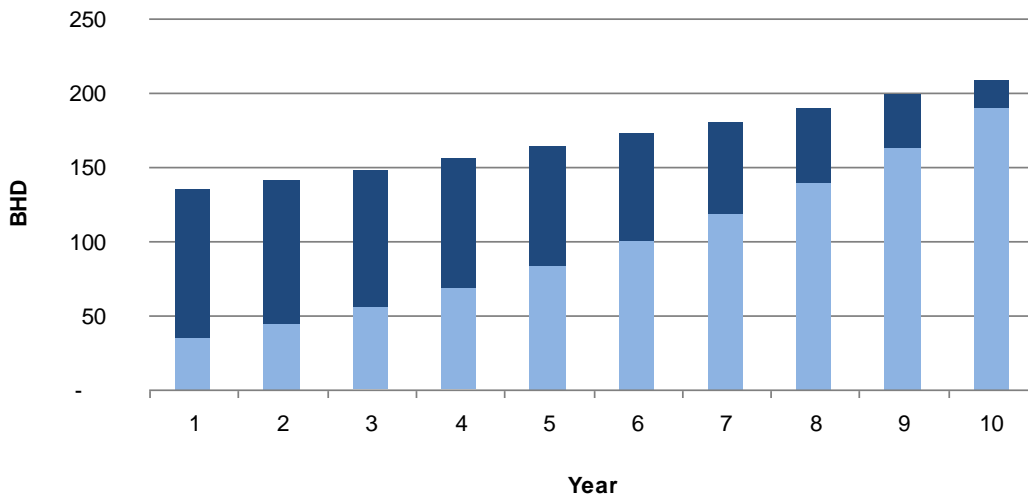

Year	1	2	3	4	5	6	7	8	9	10
Depreciation charge	34	45	56	69	84	100	119	140	163	190
Return on capital employed	100	97	92	86	80	71	61	49	35	19
<b>Annuity</b>	<b>134</b>	<b>141</b>	<b>148</b>	<b>156</b>	<b>163</b>	<b>172</b>	<b>180</b>	<b>189</b>	<b>199</b>	<b>209</b>
Sum of discounted annuities	1,000									

Source: TERA Consultants

338. Such a formula enables the sending of appropriate 'build or buy' signals to market players. If prices are falling, the annuity is higher in the early period, which signals to a new entrant

## Position Paper

### Development, implementation and use of fixed and mobile bottom-up network cost models

that building its own infrastructure today will be more expensive than building the infrastructure tomorrow. In such a case, the incumbent who owns the asset will know that a new entrant in the future will have a lower cost base. As a result, the incumbent will only invest in the market today if it can recover most of its investment at the beginning of the asset life, i.e. the depreciation profile is 'front-loaded'. In other words, the tilted annuity method sends appropriate 'build or buy' signals to market players when there are differing temporal incentives to invest. It allows regulators to replicate the annual charges that would be faced by an operator in a competitive market.

339. Even more importantly, tilted annuities allow a smooth evolution of cost despite price changes and despite investment lifecycles. Indeed, at the end of the asset's useful life, i.e. when the asset needs to be renewed, the annuity calculated with the tilted annuity method will be similar just before and just after the renewal of the asset. Therefore, annuities evolve without discontinuities<sup>116</sup> (see Figure 33). It has been demonstrated earlier that this was not the case with HCA/CCA depreciation and with standard annuities (see Figure 22 and Figure 30).

**Figure 33: Asset renewal under tilted annuity method**

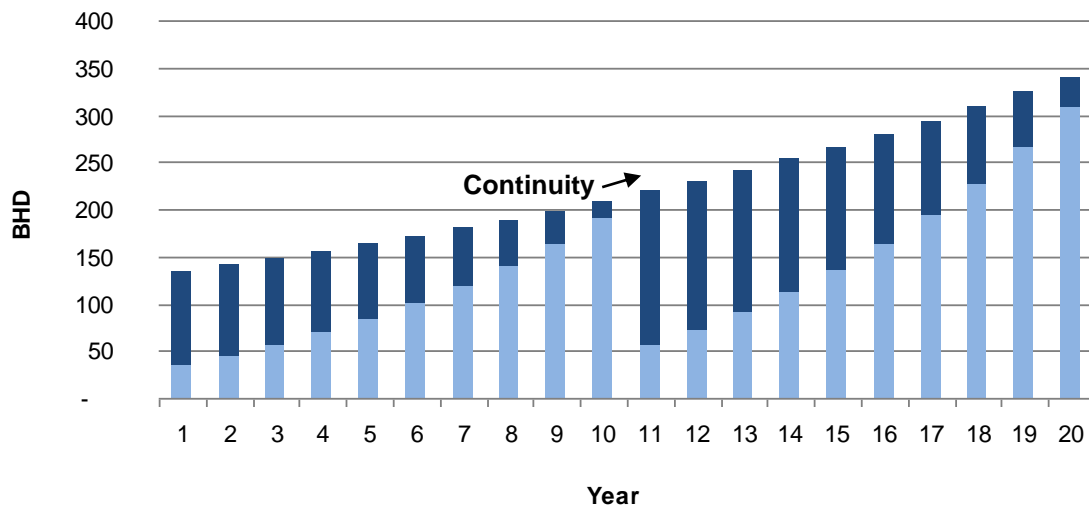

Source: TERA Consultants

### ***Adjusted tilted annuity method***

340. If the number of outputs produced by an asset is stable, then the tilted annuity is a good approximation for economic depreciation. However, the tilted annuity may not be a good proxy for economic depreciation when the level of outputs produced by an asset is not stable.<sup>117</sup> For the purposes of the following example, it is assumed that the volume of output evolves according to Figure 34. In this case, the incomes generated by the asset will not be stable over time and therefore the market value of the asset will not be stable.

<sup>116</sup> This is one of the reasons why ARCEP has chosen this depreciation method for the setting of LLU prices in 2005. See ARCEP, 2005, Décision n° 05-0834

<sup>117</sup> See ITST, Report on the LRAIC Model and User Guide Revised Hybrid Model (version 2.5.2), June 2009. See pages 33 and 34 for discussions on standard, tilted annuities and economic depreciation

## Position Paper

Development, implementation and use of fixed and mobile bottom-up network cost models

In addition, unit costs as calculated with tilted annuities will vary significantly (see Figure 35).

Figure 34: Outputs generated as a function of time

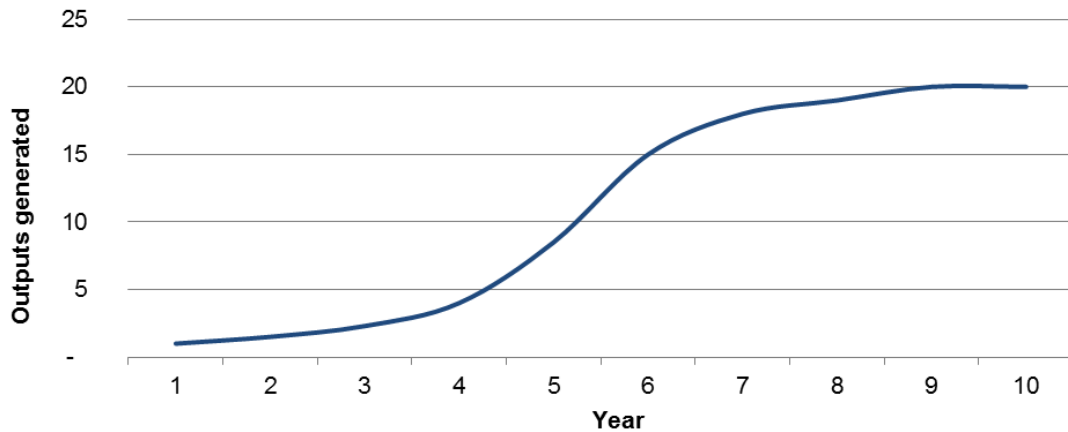

Source: TERA Consultants

Figure 35: Unit costs as a function of outputs sold under tilted annuity method

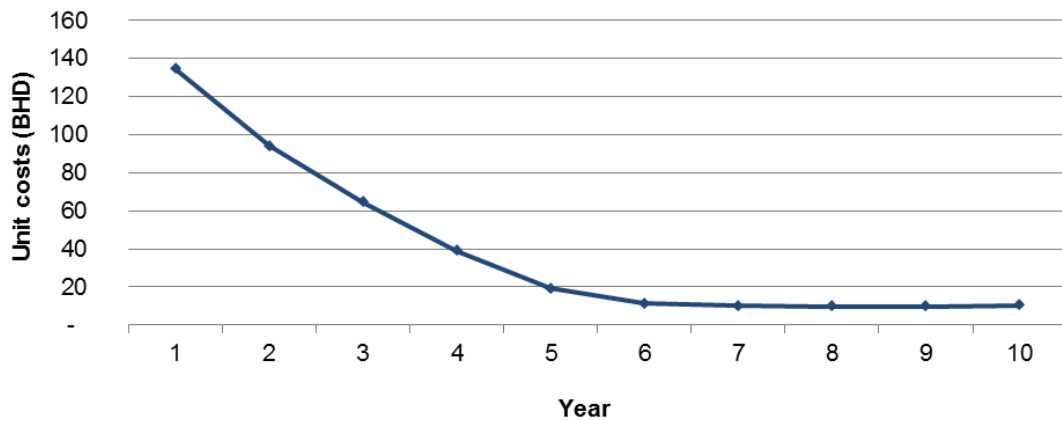

Source: TERA Consultants

341. Such evolutions can happen for new products (which have a logistic curve) or when demand is evolving fast. In this case, an adjusted tilted annuity method can be used. This will probably be the case with FTTH assets when FTTH will be deployed: the number of FTTH users will be low at the beginning but FTTH penetration can be expected to increase significantly in the long term.
342. It is possible to modify the tilted annuity formula to compute annuities that take into account the evolution of the number of outputs produced by assets. This is referred to as an adjusted tilted annuity. By accounting for changes in the number of outputs produced, annuities reflect changes in the market value of the asset, which corresponds to the definition of economic depreciation. With such an adjusted tilted annuity, the annuity per output remains stable and follows the evolution of asset prices.

### Position Paper

Development, implementation and use of fixed and mobile bottom-up network cost models

343. Let  $I$  be the investment,  $C$  the constant unit cost,  $p$  the tilt (price trend of asset) and  $N_i$  the number of outputs sold in year  $i$ . The investment can be computed as follows:

$$I = \sum_{i=1}^n \frac{C \times (1 + p)^{i-1} \times N_i}{(1 + \omega)^i}$$

344. The evolution of the net book value has the following profile (Figure 36):

Figure 36: Net book value under adjusted tilted annuity method

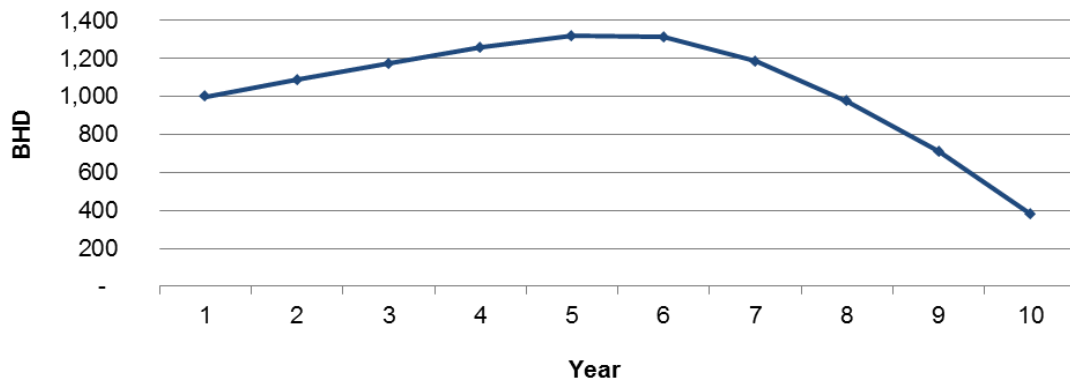

Source: TERA Consultants

345. The figures below (Figure 37 and Figure 38) illustrate the evolution of unit costs and annuities under the adjusted tilted annuity method (without taking into account evolution of asset prices).

## Position Paper

### Development, implementation and use of fixed and mobile bottom-up network cost models

**Figure 37: Unit costs as a function of outputs sold under the adjusted tilted annuity method**

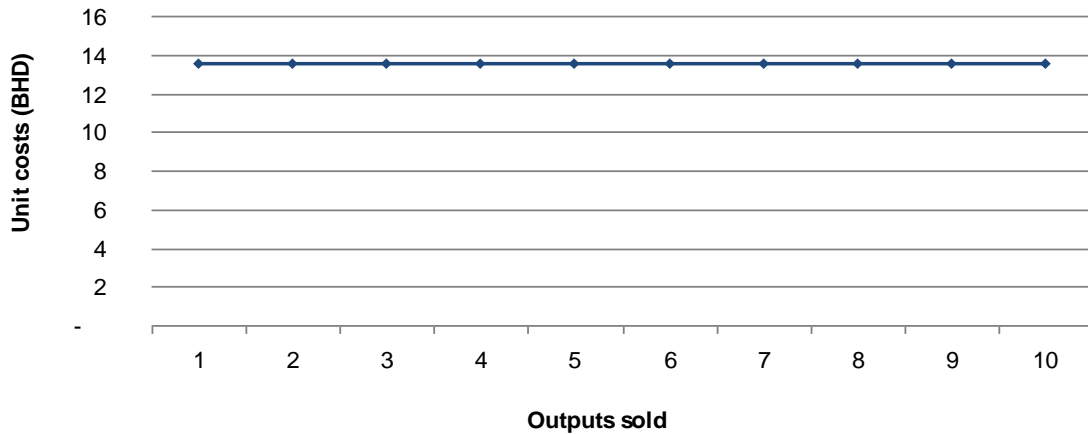

Source: TERA Consultants

**Figure 38: Annuities (depreciation charges plus return on capital employed) under the adjusted tilted annuity method**

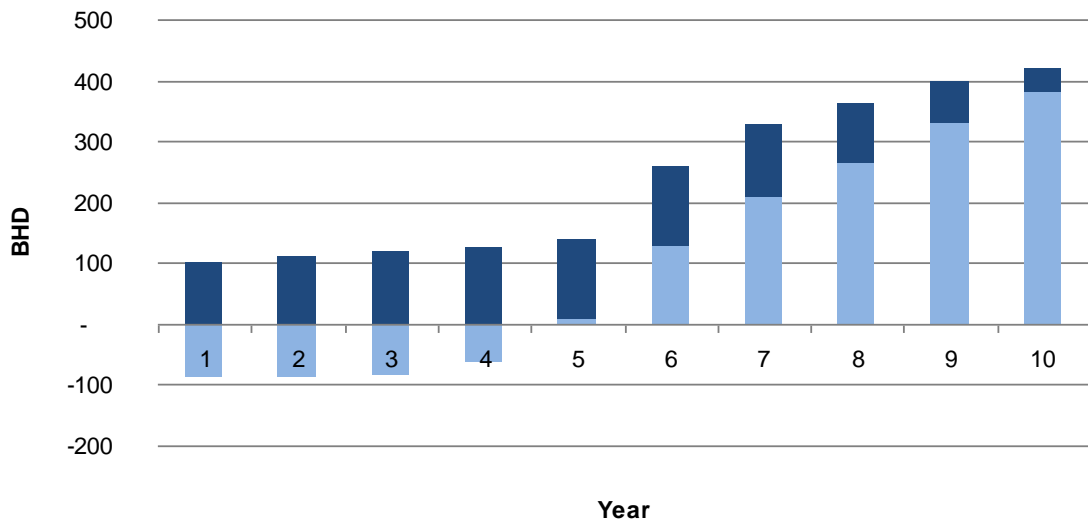

Year	1	2	3	4	5	6	7	8	9	10
<b>Depreciation charge</b>	- 86	- 87	- 83	- 63	8	128	208	264	329	382
<b>Return on capital employed</b>	100	109	117	126	132	131	118	98	71	38
<b>Annuity</b>	<b>14</b>	<b>21</b>	<b>34</b>	<b>63</b>	<b>140</b>	<b>259</b>	<b>327</b>	<b>362</b>	<b>400</b>	<b>420</b>
Sum of discounted annuities	1,000									

Source: TERA Consultants

346. The main drawback of this depreciation method is that it requires forecasts on the number of outputs produced by an asset over a long period of time. As a consequence, it is more subjective than other methods (even if the tilted annuity method is also somewhat subjective in setting long term price trends). However, it tends to give better economic signals than other depreciation methods when the number of outputs produced by an asset is not stable. If the forecast is conservative (i.e. lower than what will happen), the

## Position Paper

Development, implementation and use of fixed and mobile bottom-up network cost models

calculated annuity may generate high unit prices and slow down the evolution of the number of outputs sold in the market. By contrast, if the forecast is optimistic, the calculated annuity may generate low unit prices and speed the evolution of the number of outputs sold in the market. A virtuous circle is then created.

### ***Which depreciation method should be preferred for bottom-up models?***

347. This review of several depreciation methods shows that accounting and economic methods calculate very different annuities. Figure 39 and Figure 41 summarise the findings based on the examples discussed above, for a price trend of respectively 5% and -5%.

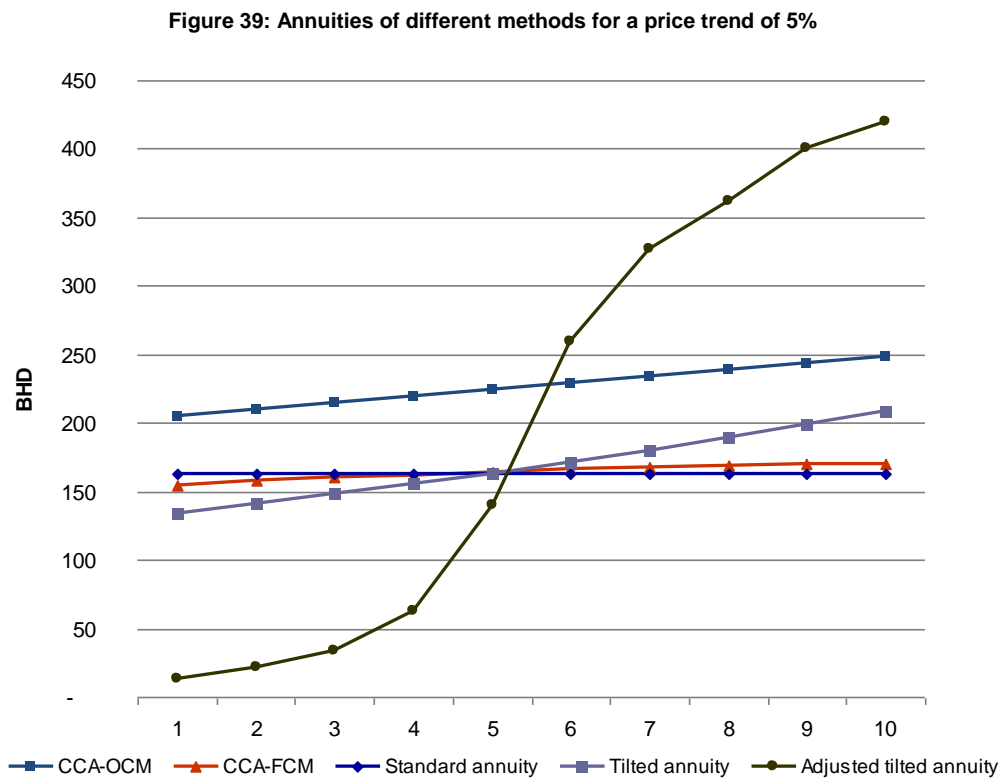

Source: TERA Consultants

## Position Paper

Development, implementation and use of fixed and mobile bottom-up network cost models

**Figure 40 – Annuities per unit of different methods for a price trend of 5%. Only the adjusted tilted annuity has a smooth evolution**

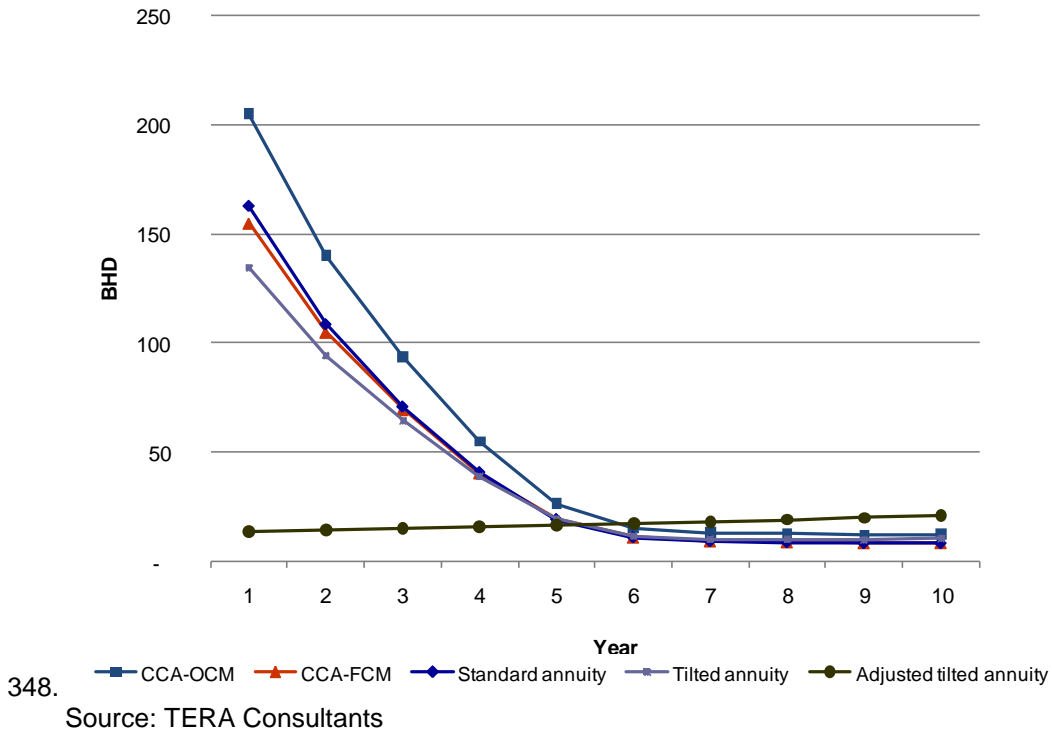

**Figure 41: Annuities of different methods for a price trend of -5%**

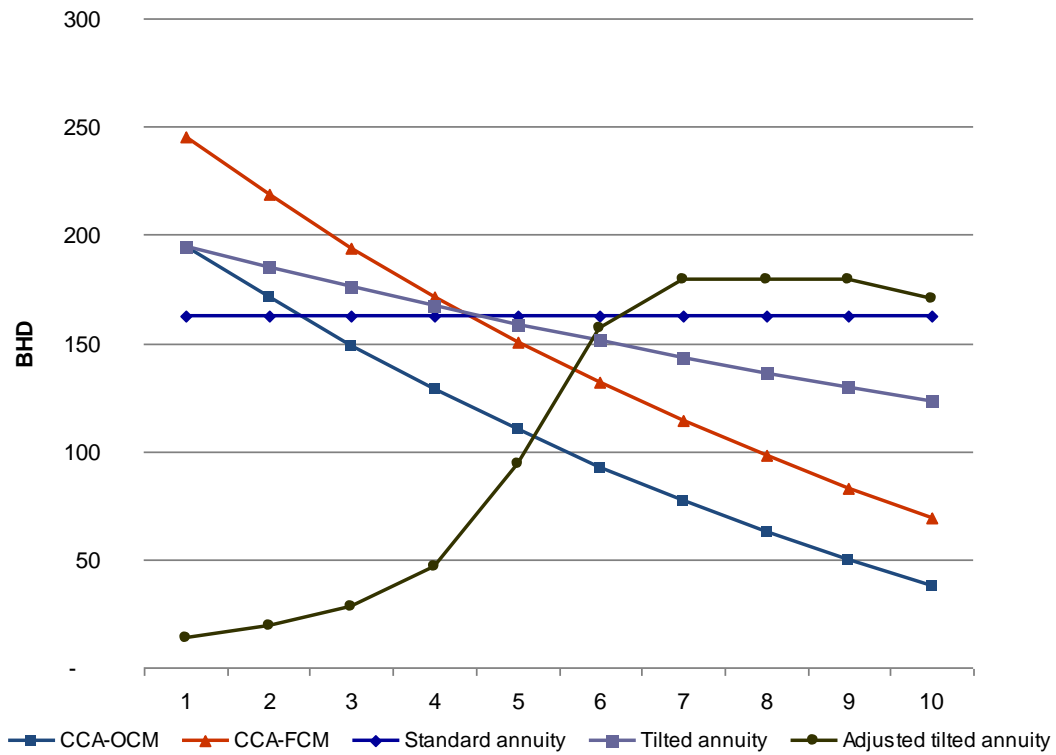

## Position Paper

### Development, implementation and use of fixed and mobile bottom-up network cost models

Source: TERA Consultants

349. Tilted annuities or adjusted tilted annuities are commonly used in telecommunications by NRAs. Indeed, telecommunication asset prices are rarely stable: in the access network, asset prices tend to increase because they are related to wages while in the core network, asset prices tend to decrease thanks to technological progress. As a consequence, NRAs use these tilted annuities to account for these price changes. For example, they have been used in the following countries for the copper local loop in recent years:

- a. France (2005);<sup>118</sup>
- b. Belgium (2007);<sup>119</sup> and
- c. Sweden (2008).<sup>120</sup>

350. Some NRAs have also recently implemented adjusted titled annuities:<sup>121</sup>

- a. AGCOM (2008);<sup>122</sup>
- b. Norway (2009);<sup>123</sup>
- c. Denmark (2009);<sup>124</sup> and
- d. Telstra has proposed this in Australia (2009).<sup>125</sup>

351. Several organizations have also recognised the benefits of tilted annuities. For example, the European Telecommunications Network Operator association (ETNO), which represents the incumbent operators of the European Union, also recommends the use of tilted annuities:<sup>126</sup>

*“ETNO therefore advocates the use of tilted annuities as a suitable approximation of economic depreciation. Under stable conditions it is a proper method, but we would still recommend it even if income or operational costs ‘develop’ differently over time, considering the problems described above regarding forward-looking valuation of capital.”*

352. Because NRAs need to send appropriate economic signals to the different market players, they generally use economic depreciation when setting regulated charges. It has been demonstrated above that tilted annuities and adjusted tilted annuities allow for this. For example, the tilted annuity is commonly considered as a good proxy for economic

---

<sup>118</sup> ARCEP Decision n° 05-834

<sup>119</sup> BIPT - het besluit van de raad van het biptvan 13 juni 2007 met betrekking tot de bruo rental fee - 13 Jun 2007

<sup>120</sup> PTS - Hybrid Model Documentation v6.1– 3 Dec 2008

<sup>121</sup> While tilted annuities take into account the level of asset price change, adjusted tilted annuities take also into account the level of output change (Agcom and Norway) and the level of operating cost change (Telstra, Denmark).

<sup>122</sup> [http://www2.agcom.it/provv/d\\_26\\_08\\_CONS/d\\_26\\_08\\_CONS\\_all\\_B.pdf](http://www2.agcom.it/provv/d_26_08_CONS/d_26_08_CONS_all_B.pdf)

<sup>123</sup> <http://www.npt.no/ikbViewer/Content/111398/Draft%20BU%20model%20specification%20distributed.pdf>

<sup>124</sup> <http://www.itst.dk/samtrafikregulering/telepriser-pa-engrosniveau/lraic/lraic-processor/lraic-fastnet/ending-af-lraic-prisfastsettelsesmetoden-2007-2009/revision-og-modellering-af-modellen-1/filarkiv/LRAIC%20Report%20on%20the%20Hybrid%20Model%20Version%202.5.pdf>

<sup>125</sup>

<http://www.accc.gov.au/content/item.phtml?itemId=867120&nodeId=b6de746c4462a2699c92f07cefce3457&fn=N ERA%20Report%20for%20Telstra.pdf>

<sup>126</sup> ETNO Reflection Document: Consultation on the ERG's PIB for LRIC – Sept. 2003

## Position Paper

Development, implementation and use of fixed and mobile bottom-up network cost models

depreciation: the Norwegian NRA and the Danish NRA have both published a report saying: *“In a fixed network, circuit-switched traffic levels are generally stable, and so tilted annuities are often chosen as a proxy for economic depreciation”*.<sup>127</sup> However, as explained above, tilted annuities are sometimes adjusted to take into account the increasing/declining level of outputs.

353. As a consequence, in bottom-up models, tilted annuities and adjusted tilted annuities shall be preferred to depreciate investments.

**Table 15: Choice of depreciation methods**

		Standard annuity	Tilted annuity	Adjusted tilted annuity
Number of outputs is stable	Asset prices are stable	✓		
	Asset prices are evolving		✓	
Number of outputs is <u>not</u> stable	Asset prices are stable			✓
	Asset prices are evolving			✓

Source: TERA Consultants

### ***Time to build period***

354. The standard annuity, tilted annuity and adjusted tilted annuity formulas described above calculate annual charges which occur each year, the first annuity beginning one year after the investment has been incurred. This implicitly means that the operator begins receiving revenues from its asset only one year after the investment is completed (it can then use this money to reimburse shareholders and banks) (see footnote 114). The duration between the moment the operator pays for the asset and the moment it begins generating cash from the asset is called the ‘time to build’ in this annex. The time to build period can vary significantly from one asset to another. Many factors influence the time to build period:

- When an operator invests in an asset, it may be able to negotiate a longer payment term with its suppliers (i.e. the ability to pay for the asset at a time after its delivery and installation). However, when the operator invests in an asset with its internal resources and its own employees, it will have to pay these resources at the end of each month, and therefore the payment for the asset is incurred at the time of installation.
- When an operator has installed an asset, it may either receive revenues from this asset every month (which is most probably the case for retail mass market products) or every year or even in advance (for example, 3 months in advance).

355. The important point that must be highlighted with time to build periods is that the longer they are, the higher the financial costs are that will be borne by the operator. As the return on capital represents the opportunity cost of funds tied up in the investment, a one year

---

<sup>127</sup> NPT, Conceptual approach for a LRIC model for wholesale mobile voice call termination. Consultation paper for the Norwegian mobile telecoms industry and 27 February 2006 Analysys, LRAIC model of mobile termination: specification consultation paper for industry, 2007

## Position Paper

Development, implementation and use of fixed and mobile bottom-up network cost models

increase in the time to build period leads to the scaling up of annuities by a factor  $(1+WACC)$ .

356. The present section aims at demonstrating the tilted annuity formula with the specific focus on the time to build period. Basically, the tilted annuity formula consists of calculating the annual costs  $A_1, A_2, A_3$ , etc., for a given asset representing an investment  $I$  at time  $T$ , over the life of the asset that this investment represents (Figure 42).

**Figure 42 – Chronology, investment and annual costs**

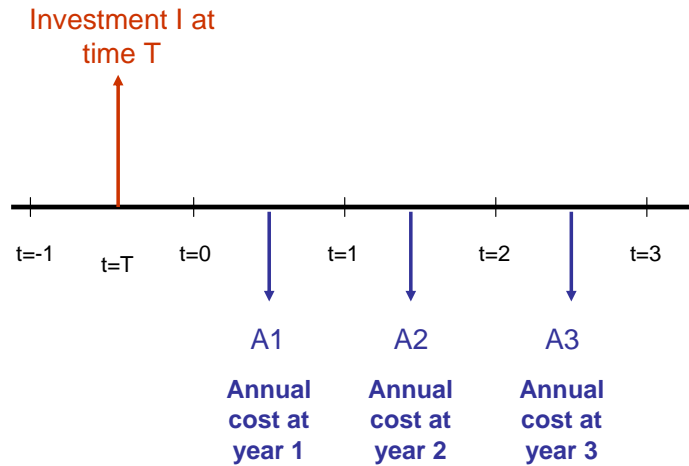

Source: TERA Consultants

### **Calculation of the annual cost at year 1 given an investment at time T:**

357. Literally, the problem to be solved requires equalizing the net present value of the investment (i.e. the value of the investment at  $t=0$ ) and the net present value of the future annual costs corresponding to the investment.

$$NPV(I) = \sum_{i=1}^{i=N} NPV(A_i) \quad (1)$$

358. Where  $NPV(I)$  is the net present value of the investment  $I$  and  $\sum_{i=1}^{i=N} NPV(A_i)$  is the net present value of annual costs.

359. Annual costs are assumed to be covered by annual revenues. Thus average costs are assumed to occur at the year midpoint (end of June).<sup>128, 129</sup> The net present values of annual costs  $A_1, A_2 \dots A_i$  (at year  $i$ ) can be expressed as follows:

$$NPV(A_1) = \frac{A_1}{\sqrt{1+\omega}} \quad \text{where } \omega \text{ is the WACC}$$

<sup>128</sup> Assuming annual charge at the average of the year is consistent with the fact that operators are getting paid on a monthly basis.

<sup>129</sup> NB: It is assumed that prices do not move between the moment the investment is paid and the moment the first revenues are received.

## Position Paper

Development, implementation and use of fixed and mobile bottom-up network cost models

$$NPV(A_2) = \frac{A_2}{\sqrt{1+\omega} \times (1+\omega)}$$

...

$$NPV(A_i) = \frac{A_i}{\sqrt{1+\omega} \times (1+\omega)^{i-1}} \quad (2)$$

360. Annual costs are assumed to vary each year with the price trend  $P$ . Thus annual cost  $A_i$  at year  $i$  can be expressed as a function of annual cost  $A_1$  at year 1 as follows:

$$A_i = A_1 \times (1+P)^{i-1} \quad (3)$$

361. We derived from equations (2) and (3):

$$NPV(A_i) = \frac{A_1}{\sqrt{1+\omega}} \left( \frac{1+P}{1+\omega} \right)^{i-1} \quad (4)$$

362. Using equation (4), the sum of net present values is:

$$\sum_{i=1}^{i=N} NPV(A_i) = \sum_{i=1}^{i=N} \frac{A_1}{\sqrt{1+\omega}} \left( \frac{1+P}{1+\omega} \right)^{i-1} \quad (5)$$

363. The term  $\frac{A_1}{\sqrt{1+\omega}}$  is a constant, so it can be factorised in equation (5):

$$\sum_{i=1}^{i=N} NPV(A_i) = \frac{A_1}{\sqrt{1+\omega}} \sum_{i=1}^{i=N} \left( \frac{1+P}{1+\omega} \right)^{i-1} \quad (6)$$

364. The term  $\sum_{i=1}^{i=N} \left( \frac{1+P}{1+\omega} \right)^{i-1}$  is calculated as the sum of a geometric series. Equation (6) is then expressed as follows:

$$\sum_{i=1}^{i=N} NPV(A_i) = \frac{A_1}{\sqrt{1+\omega}} \frac{1 - \left( \frac{1+P}{1+\omega} \right)^N}{1 - \left( \frac{1+P}{1+\omega} \right)} \quad (7)$$

365. Simplifying (7), we obtain:

$$\sum_{i=1}^{i=N} NPV(A_i) = \frac{A_1 \times \sqrt{1+\omega}}{\omega - P} \left[ 1 - \left( \frac{1+P}{1+\omega} \right)^N \right] \quad (8)$$

366. The net present value of the investment at time  $T$   $NPV(I)$  can be expressed as follows:

$$NPV(I) = \frac{I}{(1+\omega)^T} \quad (9)$$

## Position Paper

Development, implementation and use of fixed and mobile bottom-up network cost models

367. Equations (9) and (8) can then be inserted into equation (1):

$$\frac{I}{(1+\omega)^T} = \frac{A_1 \times \sqrt{1+\omega}}{\omega - P} \left[ 1 - \left( \frac{1+P}{1+\omega} \right)^N \right] \quad (10)$$

368. The annual cost at year 1 is then isolated in equation (10):

$$A_1 = \frac{I}{(1+\omega)^{T+\frac{1}{2}}} \times \frac{\omega - P}{\left[ 1 - \left( \frac{1+P}{1+\omega} \right)^N \right]} \quad (11)$$

369. As a consequence, formula (12) below means that the investment is done at the same time than revenues are collected (or annuities are paid):

$$A_1 = \frac{I}{(1+\omega)} \times \frac{\omega - P}{\left[ 1 - \left( \frac{1+P}{1+\omega} \right)^N \right]} \quad (12)$$

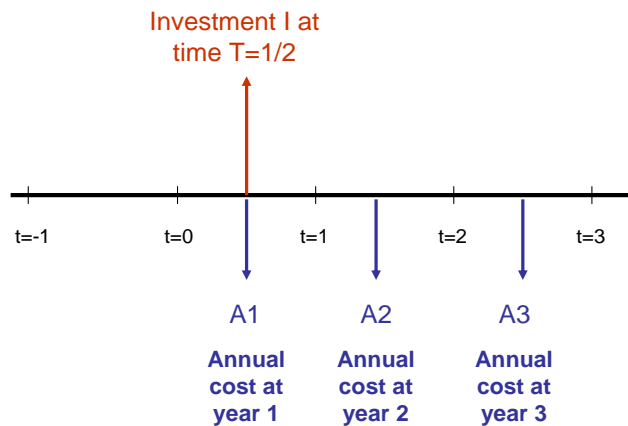

Source: TERA Consultants

370. Formula (13) is consistent with the one used by the Belgian Regulatory Authority<sup>130</sup>. It means that the investment is paid once at the beginning of the year and the operator begins to earn revenues from this investment at t=0. Thus the average revenues are perceived at t=1/2.

$$A_1 = \frac{I}{\sqrt{1+\omega}} \times \frac{\omega - P}{\left[ 1 - \left( \frac{1+P}{1+\omega} \right)^N \right]} \quad (13)$$

<sup>130</sup> See for example IBPT, Bottom-up model for interconnection description of the methodology, Prepared by BIPT In collaboration with Bureau van Dijk Management Consultants, 08 June 2004

## Position Paper

Development, implementation and use of fixed and mobile bottom-up network cost models

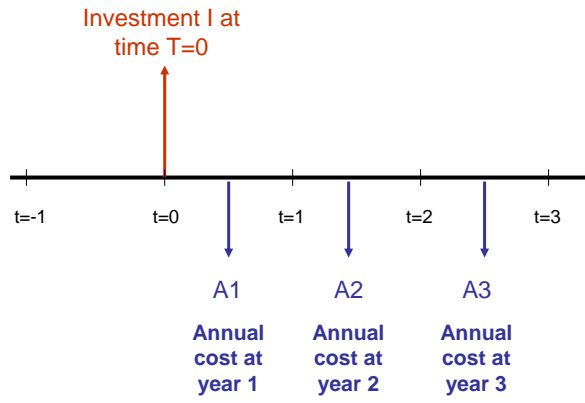

Source: TERA Consultants

## Position Paper

Development, implementation and use of fixed and mobile bottom-up network cost models

### 10 Annex C –International regulatory approaches on methodological issues

371. As part of this exercise, the Authority has reviewed the methodological approaches taken by other NRAs. The results of the Authority's review of international experience are summarised in this Annex (where information is not available, this is highlighted in grey). The countries covered in the benchmark have been included on the basis of information availability, detailed scrutiny of the cost model by the regulator, and public consultation.

#### 10.1 Fixed core model<sup>131</sup>

372. For fixed core network models, five countries have been selected. The NRAs in these 5 countries publish information on cost models developed. In addition, with populations of between 4 and 5 million inhabitants, Denmark and Ireland are smaller countries which can be of particular interest in the case of Bahrain.

##### *Scorched node / scorched earth*

	Scorched node	Scorched earth
Denmark	✓	
Sweden	✓	
Ireland	✓	
France	✓	
Australia	✓	

Source: TERA Consultants

---

<sup>131</sup> Benchmarked models are calculating the costs of all services in Denmark, Sweden and Australia, of fixed termination rates only in France and of NGN and legacy leased lines in Ireland.

**Denmark:** T- og Telestyrelsen (Denmark), November 2009, Report on the LRAIC Model and User Guide - Revised Hybrid Model (version 3.1)

**Sweden:** PTS (Sweden), September 2009, Hybrid Model Documentation v7.0.

**Ireland:** ComReg (Ireland), September 2010, Document No 10/70

**France:** ARCEP (France), January 2011, « modele-cout-ta-fixe-070111" »

**Australia:** ACCC (Australia), December 2008, Analysys, Cost model for Australian fixed network services

## Position Paper

Development, implementation and use of fixed and mobile bottom-up network cost models

### Technologies modelled

	Core technology
Denmark	NGN
Sweden	NGN
Ireland	Legacy/NGN (depending on products)
France	NGN
Australia	Legacy in migration to NGN

Source: TERA Consultants

### Yearly vs. Historical

	Yearly	Historical
Denmark	✓	
Sweden	✓	
Ireland	✓	
France		✓
Australia		

Source: TERA Consultants

### Treatment of OPEX

	Based on operator accounts	Bottom-up modelling	Based on international mark-ups benchmark
Denmark		✓	
Sweden		✓	
Ireland	✓		
France	✓		✓ (sanity check)
Australia			

Source: TERA Consultants

## Position Paper

Development, implementation and use of fixed and mobile bottom-up network cost models

### Cost allocation

	Required capacity	Other method
Denmark	✓	
Sweden	✓	
Ireland	✓	Shapley-Shubik allocation implemented but not used to set prices
France	✓	Shapley-Shubik allocation implemented in another ARCEP model (fixed NGN network) <sup>132</sup>
Australia	✓	

Source: TERA Consultants

### Treatment of corporate overheads

	EPMU	Ramsey	Not taken into account ( <i>Pure LRIC approach</i> )
Denmark	✓		
Sweden	✓		
Ireland	✓		
France			✓
Australia	✓		

Source: TERA Consultants

### Depreciation method

	HCA	CCA ( <i>OCM/FCM</i> )	Standard annuity	Tilted annuity	Adjusted tilted annuity ( <i>economic depreciation</i> )
Denmark	✓	✓ ( <i>FCM</i> )		✓	✓
Sweden	✓		✓	✓	
Ireland				✓	
France <sup>133</sup>	✓	✓ ( <i>OCM/FCM</i> )	✓	✓	
Australia				✓	

In yellow, preferred approach (if any)  
Source: TERA Consultants

<sup>132</sup> ARCEP decision 08-0896. The Authority explains that this allocation methodology's main quality is that it ensures that any service benefits from sharing, even though it could have been produced in a cheaper way using another technology.

<sup>133</sup> The final decision has not been issued yet. At this stage the Authority has just conducted a sensitivity analysis on the different choices of depreciation method.

## Position Paper

Development, implementation and use of fixed and mobile bottom-up network cost models

### Working capital

	Not included	Included
Denmark		✓
Sweden	✓	
Ireland	✓	
France	Consistently excluded unless audited <sup>134</sup>	
Australia	✓ <sup>135</sup>	

Source: TERA Consultants

### 10.2 Mobile model<sup>136</sup>

373. For mobile models, five countries have been selected. These 5 countries publish information on cost models developed.

### Scorched node / scorched earth

	Scorched node	Scorched earth
Denmark	✓	
Sweden	✓	
UK	✓	
France	✓	
Australia		✓

Source: TERA Consultants

<sup>134</sup> ComReg – Decision 0939, page 59, based on the wording of the decision, it is not clear what “audited” refers to.

<sup>135</sup> ComReg – Decision 0939, page 59, based on the wording of the decision

<sup>136</sup> Benchmarked models are calculating the costs of mobile termination rates in all countries

**Denmark:** Report for NITA (Denmark), May 2007, “LRAIC model of mobile termination: specification consultation paper for industry”

**Sweden:** Report for PTS (Sweden), September 2010, LRAIC model of mobile termination: specification consultation paper for industry

**UK:** Ofcom, March 2011, Wholesale mobile voice call termination

**France:** Analysys, March 2011 Model documentation for ARCEP - ARCEP, May 2011, Décision n° 2011-0483

**Australia:** Report for the ACCC (Australia), January 2007, “Mobile Termination Cost Model for Australia”

## Position Paper

Development, implementation and use of fixed and mobile bottom-up network cost models

### Technologies to be modelled

	Core technology
Denmark	2G-3G / 3G only
Sweden	2G-3G (+some LTE equipment)
UK	2G-3G
France	2G-3G
Australia	2G (+some 3G equipment)

Source: TERA Consultants

### Yearly vs. Historical

	Yearly	Historical
Denmark		✓
Sweden		
UK		✓
France		✓
Australia	✓	

Source: TERA Consultants

### Treatment of OPEX

	Based on operator accounts	Bottom-up modelling	Based on international mark-ups benchmark
Denmark			
Sweden			
UK		✓	
France	✓ (with adjustments)		
Australia			✓

Source: TERA Consultants

## Position Paper

Development, implementation and use of fixed and mobile bottom-up network cost models

### Cost allocation

	Required capacity	Other method
Denmark	✓	
Sweden	✓	
UK	✓	
France	✓	
Australia	✓	

Source: TERA Consultants

### Treatment of corporate overheads

	EPMU	Ramsey	Not taken into account (Pure LRIC approach)
Denmark	✓		
Sweden	✓		
UK			✓
France			✓
Australia	✓		

Source: TERA Consultants

### Depreciation method

	HCA	CCA (OCM/FCM)	Standard annuity	Tilted annuity	Adjusted tilted annuity (economic depreciation)
Denmark	✓	✓		✓	✓
Sweden					✓
UK					✓
France					✓
Australia				✓	

In yellow, preferred approach (if any)

Source: TERA Consultants

### Working capital

	Not included	Included
Denmark		✓
Sweden		
UK		
France		
Australia		✓

Source: TERA Consultants

## Position Paper

Development, implementation and use of fixed and mobile bottom-up network cost models

### 11 Annex D – European and Australian benchmark on costing approaches

374. This annex reviews the costing methodologies used by major European countries and Australia for local loop unbundling, mobile termination rates and fixed termination rates.

#### 11.1 Benchmark for local loop unbundling

375. CCA+LRIC (either bottom-up or top-down, the distinction between BU and TD was not performed in the 2010 survey) is the most widely used costing methodology for LLU, and the Bureau of European Regulators for Electronic Communications (BEREC) states that *“this trend is likely to be reinforced by the NGA Recommendation expected to be adopted in September 2010.”*<sup>137</sup>

**Table 16: Methodologies used by major European countries for LLU**

	Top-down Historical costs FDC (HCA)	Top-down Current costs FDC (CCA)	Top-down Current costs LRIC (TD-LRIC)	Bottom-up Current costs LRIC (BU-LRIC)
<b>Austria</b>				✓
<b>Belgium</b>				✓
<b>Denmark</b>		✓		✓
<b>Finland</b>	✓			
<b>France</b>		✓ <sup>138</sup>		
<b>Germany</b>				✓
<b>Italy</b>	✓			
<b>Ireland</b>				✓
<b>Netherlands</b>			✓	
<b>Portugal</b>	✓			
<b>Spain</b>		✓		
<b>Sweden</b>				✓
<b>United Kingdom</b>		✓		

Source: NRA Websites, ComReg 08/56 (Proposals for local loop unbundling pricing methodologies).

<sup>137</sup> BEREC Report BoR (10) 48, Regulatory Accounting in Practice 2010, October 2010 (page 22).

<sup>138</sup> ARCEP uses tilted annuities to depreciate investments rather than accounting depreciation

## Position Paper

Development, implementation and use of fixed and mobile bottom-up network cost models

### 11.2 Benchmark for mobile networks (termination rates)

376. Results presented below show that BU-LRIC is the preferred methodology for modelling mobile termination rates, and the BEREC states that although the development of cost models is recent, BU-LRIC will remain the preferred approach: “*The trend analysis suggests that the development of costing tools is still relatively new. But this could change in the near future with the implementation of the EC Recommendation on the Regulatory Treatment of Fixed and Mobile Terminations Rates in the EU (2009/396/EC) where CCA and LRAIC (BULRAIC alone or combination of BU-LRAIC and TD-LRAIC) is foreseen as a first option.*”<sup>139</sup>

Table 17: Methodologies used by major European countries (and Australia) for mobile termination rates

	Top-down Historical costs FDC HCA	Top-down Current costs FDC CCA	Top-down Current costs LRIC TD-LRIC	Bottom-up Current costs LRIC BU-LRIC
Austria				✓
Australia				✓
Belgium				✓
Denmark			✓	✓
Finland		✓		
France			✓	✓
Germany			✓	✓
Greece				✓
Italy				✓
Ireland	Benchmarking			
Luxembourg	Benchmarking			
Norway				✓
Netherlands				✓
Portugal	Benchmarking (but future model will be BU-LRIC)			
Spain				✓
Sweden			✓	✓
United Kingdom			✓	✓

Note: The table summarises the current or planned situation by NRAs.  
Source: NRA Websites, Cullen International.

### 11.3 Benchmark for fixed core network (termination rates)

377. There is insufficient publicly available information to perform a comprehensive review, but the BEREC performs an anonymous benchmarking exercise every year. The 2010 survey on fixed termination was performed along two axes: FDC vs. LRIC and HCA family vs.

<sup>139</sup> BEREC Report BoR (10) 48, Regulatory Accounting in Practice 2010, October 2010 (page 33).

## Position Paper

### Development, implementation and use of fixed and mobile bottom-up network cost models

CCA family or “forward-looking”<sup>140</sup> (the distinction between BU and TD was not performed in the 2010 survey). Results presented below show that FL-LRIC is the preferred methodology, and the BEREC states that “*this trend will likely be reinforced with the implementation of the EC Recommendation on the Regulatory Treatment of Fixed and Mobile Termination Rates in the EU (2009/396/EC)*”:<sup>141</sup>

**Table 18: Methodologies used by European countries for fixed termination rates (2010 survey)**

	Proportion of NRAs by cost base methodology (historical/current) and accounting methodology (FDC/LRIC)
<b>Historical costs</b>	15%
<b>Forward-looking</b>	80%
<b>Other</b>	5%
<b>FDC</b>	25%
<b>LRIC</b>	70%
<b>Other</b>	5%

Note: In 2010 20 NRAs replied to the fixed questionnaire (the BEREC does not display results on top-down vs. bottom-up methodology for the 2010 survey).

Source: BEREC (Regulatory Accounting in Practice 2010), TERA Consultants.

378. As a piece of information, the 2009 BEREC survey asked for the fixed market as a whole if the model used to ensure cost-orientation was bottom-up or top-down (the BEREC does not provide this information for the specific fixed termination market).

**Table 19: Methodologies used by European countries for fixed market (2009 survey)**

Type of model used to monitor compliance with cost orientation	Bottom-up	Top-down	Hybrid
<b># NRAs that always use this model</b>	2	9	3
<b># NRAs that selectively use this model</b>	8	5	1

Note: In 2009 21 NRAs replied to the fixed questionnaire; but total figure does not equal 21 as some NRAs do not use a cost model while other NRAs use several cost models depending on the purposes.

Source: BEREC (Regulatory Accounting in Practice 2009), TERA Consultants

<sup>140</sup> “For the Cost base: HCA Family (Historical Cost Accounting); CCA Family (Current Cost Accounting and Forward Looking - Current Cost Accounting)” BEREC Report BoR (10) 48, Regulatory Accounting in Practice 2010, October 2010 (page 6).

<sup>141</sup> BEREC Report BoR (10) 48, Regulatory Accounting in Practice 2010, October 2010 (page 31).

## Position Paper

Development, implementation and use of fixed and mobile bottom-up network cost models

### References

- AAPT & CoRE Research (Australia), 23 July 2003, *Comparing TSLRIC and TELRIC*
- Accounting standards Board, June 2000, Amendment to FRS 15 'tangible fixed assets' and FRS 10 'goodwill and intangible assets': interest methods of depreciation
- Analysys & PTS (Sweden), September 2010, Long run incremental cost modelling of mobile termination in Sweden
- Andersen & European Commission DG Information Society, July 2002, Study on the implementation of cost accounting methodologies and accounting separation by telecommunication operators with significant market power
- Australian Competition and Consumers Commission (ACCC), 2008, *Appendix A: Economic rationale for the tilted annuity*
- Australian Competition and Consumers Commission (ACCC), September 2010, Review of the 1997 telecommunications access pricing principles for fixed line services - Draft report
- Autorité de régulation des communications électroniques et des postes (ARCEP, France), April 2005, *Consultation on copper local-loop costing methods*
- Autorité de régulation des communications électroniques et des postes (ARCEP, France), 15 December 2005, Décision n° 05-0834 définissant la méthode de valorisation des actifs de la boucle locale cuivre ainsi que la méthode de comptabilisation des coûts applicable au dégroupage total
- Autorité de régulation des communications électroniques et des postes (ARCEP, France), June 2007, Les référentiels de coûts des opérateurs mobiles
- Cave M., August 2005, Investment incentives and local loop prices
- Commerce Commission (New Zealand), 20 February 2004, Telecommunications Act 2001 - Implementation of TSLRIC - Pricing Methodology for Access Determinations under the Telecommunications Act 2001 - PRINCIPLES PAPER
- ComReg (Ireland), July 2008, Proposals for Local Loop Unbundling Pricing Methodologies
- ComReg (Ireland) & RGL Forensics, 16 February 2009, Final report for ComReg – *Review of Eircom's regulatory asset lives*
- ComReg (Ireland), 17 February 2009, Review of the regulatory asset lives of Eircom Limited [09/11]
- ComReg (Ireland), April 2009, Further reductions in mobile termination charges by Vodafone, O2, and Meteor will benefit consumers [09/32]
- ComReg (Ireland), May 2009, Further Consultation on Local Loop Unbundling ('LLU') and Sub Loop Unbundling ('SLU') Monthly Rental Charges [09/39]
- ComReg (Ireland), September 2010, Further specification of the price control obligation, the transparency obligation and the access obligation in relation to the market for wholesale terminating segment of leased lines [10/70]
- Cyprus Telecommunications Authority (CYTA), 2006, *LRAIC and accounting separation*

## Position Paper

Development, implementation and use of fixed and mobile bottom-up network cost models

DeLeeuw International, Gide Loyrette Nouel, Gide Turkey & Tera Consultants, Consultation Paper on a Proposed Bottom Up and Long Run Average Incremental Costs (BU-LRAIC) Costing Methodology for Interconnection and Access Services in the Turkish Fixed Telecommunications sector

DeLeeuw International, Gide Loyrette Nouel, Gide Turkey & Tera Consultants, Consultation Paper on a Proposed Bottom Up and Long Run Average Incremental Costs (BU-LRAIC) Costing Methodology for Interconnection in the Turkish Mobile Telecommunications sector

ERG, 2005, ERG COMMON POSITION: Guidelines for implementing the Commission Recommendation C (2005) 3480 on Accounting Separation & Cost Accounting Systems under the regulatory framework for electronic communications

ERG, 2007, ERG public consultation on a draft Common Position on symmetry of mobile/fixed call termination rates [ERG (07) 83]

Ergas H., August 2008, *Depreciation*

European Commission, 19 September 2005, Commission recommendation on accounting separation and cost accounting systems under the regulatory framework for electronic communications [2005/698/EC]

European Commission, May 2009, Commission recommendation on the regulatory treatment of fixed and mobile termination rates in the EU [2009/396/EC]

European Commission, May 2009, Commission recommendation on the regulatory treatment of fixed and mobile termination rates in the EU - Explanatory note

Finnish Communications Regulatory Authority (FCRA) & Frontier Economics, December 2005, Developing the evaluation process for determining the cost oriented mobile termination prices in Finland

GSMA, The setting of mobile termination rates: Best practice in cost modelling

Hardin A., Ergas H. & Small J., 1999, Economic Depreciation in Telecommunications Cost Models

International Telecommunication Union (ITU), November 2010, *Valuation mobile networks*

Laffont and Tirole, 2001, *Competition in Telecommunications*, Cambridge: MIT Press

OFCOM (UK), April 2010, Wholesale mobile voice call termination Market Review – Main consultation

T- og Telestyrelsen (Denmark), June 2009, Report on the LRAIC Model and User Guide - Revised Hybrid Model (version 2.5.2)

TRA Bahrain, February 2010, The regulation of mobile termination services – Position Paper [MCD/02/10/011]

World Bank & PPIAF, A Model for Calculating Interconnection Costs in Telecommunications

## Position Paper

Development, implementation and use of fixed and mobile bottom-up network cost models

### Annex A: List of questions included in the consultation document

The following list of questions is extracted from the draft Position Paper that was issued for public consultation on 19 May 2011.

- Q1. Do respondents agree with the Authority's preliminary view to implement both pure LRIC and LRIC+ approaches for services handled by the fixed core and the mobile networks? Please elaborate.
- Q2. Do respondents agree with the Authority's preliminary view to implement both the required capacity and the Shapley-Shubik allocation methods for joint and common network costs in the bottom-up models? Please elaborate.
- Q3. Do respondents agree with the Authority's preliminary view to allocate un-attributable costs (non-network common costs) on the basis of the EPMU approach? Please elaborate.
- Q4. Do respondents agree with the choice of the scorched node approach for bottom-up cost models? Please elaborate.
- Q5. Do respondents agree with the proposed approach for mobile network cost modelling, and in particular the generic operator? Please elaborate.
- Q6. Do respondents agree with the Authority preliminary position regarding the type of technologies (2G + 3G) to be modelled? Please elaborate.
- Q7. Do respondents agree with the Authority preliminary position regarding the spectrum to be considered when modelling the costs of mobile networks? Please elaborate.
- Q8. Do respondents agree with the Authority preliminary position regarding the treatment of license costs and frequency usage fees? Please elaborate.
- Q9. Do respondents agree with the Authority preliminary view regarding the type of technologies to be considered when modelling the costs of the fixed core network? Please elaborate
- Q10. What is the respondents' view on the type of fibre architecture and technology that should be modelled for the NGA? Please elaborate and formulate substantiated alternative proposal if necessary.
- Q11. Do respondents agree with the Authority's preliminary view on proposed 'yearly approach' to network dimensioning optimisation? Please elaborate
- Q12. Do respondents agree with the list of services to be considered in the bottom-up cost models? If there is any service requiring significant capacity that is not listed above, please specify it.
- Q13. Do respondents agree with the Authority's preliminary view on the treatment of OPEX in the bottom-up cost models? Please elaborate
- Q14. Do respondents agree with the Authority's preliminary view to implement tilted annuities or adjusted tilted annuities in the bottom-up cost models? Please elaborate
- Q15. Do respondents agree with the Authority's view that economic asset lives should be used in bottom-up models? Please elaborate.

## Position Paper

### Development, implementation and use of fixed and mobile bottom-up network cost models

- Q16. Do respondents agree with the Authority's preliminary view to exclude the working capital which is not related to the network activities or the provision of services?
- Q17. Do respondents agree with the Authority's preliminary view that, except for working capital generated by CAPEX which is taken into account through depreciation formulas, the cost of working capital related to network OPEX should be excluded from the cost model unless operators can provide evidence of a significant and efficient level of such working capital? Please elaborate.
- Q18. Do respondents agree with the Authority's preliminary view that it may be appropriate in some cases to use gradients for the setting of regulated prices based on bottom-up models? Please elaborate.
- Q19. Do you agree with the Authority's preliminary view to model annual costs over a 4 to 5-year period notably to give visibility to operators and to enable the setting of regulated charges for multi-year periods? Please elaborate.
- Q20. Do respondents have any comments and suggestions regarding the overall potential structure of bottom-up models that the Authority intends to develop?
- Q21. Do respondents agree with the anticipated timeline for the development and implementation of the bottom-up cost models? Please elaborate.
- Q22. Do respondents agree with the key steps described in sections 6.1, 6.2, and 6.3 anticipated by the Authority for the development, implementation and validation of bottom-up cost models? Please elaborate.
- Q23. Do respondents agree with the proposed strategy to involve relevant operators (Batelco, Zain and Viva) in the development and validation of the models? Please elaborate.
- Q24. Do respondents have any comments regarding the above discussion (*i.e. the use of bottom-up model*)? Please elaborate.
- Q25. Do respondents agree that consideration should be given to setting access and interconnection prices over a medium-term time horizon such as 3 years? Please elaborate.
- Q26. Do respondents agree that in some cases, when there is a significant gap between service costs calculated today and before (due for example to the move from a top-down cost model to a bottom-up cost model), the use of a glide path might be appropriate to move from existing prices to the appropriate cost-based level? Please elaborate.