

TELECOMMUNICATIONS REGULATORY AUTHORITY BAHRAIN



هيئة تنظيم الاتصالات
Telecommunications Regulatory Authority

Bahrain Number Portability Implementation

Routing and Charging specification

Version: 0.4
Status: draft
Date: 14-01-2010

Modification History

Issue	Date	Modification
0.1	02-10-2009	First draft specification document
0.2	16-11-2009	Second draft, incorporated issues as agreed within RC WG
0.3	09-12-2009	Review of specification text, clarifications, and proof-reading in preparation for public consultation
0.4	14-01-2010	Formatting changes

Distribution

Issue	Date	Addressees
0.1	02-10-2009	Routing and Charging Working Group (RC WG), TRA
0.2	16-11-2009	Routing and Charging Working Group (RC WG), TRA
0.3	09-12-2009	TRA
0.4	14-01-2010	Public Consultation

Review History

Issue	Date	Review By
0.1	26-10-2009	ZAIN

Referenced Documents

Reference	Description
[1]	Number Portability, A Regulation issued by the Telecommunications Regulatory Authority;
[2]	National Numbering Plan; 10-09-2008; final version;
[3]	MNP Process Specification; 14-01-2010; DRAFT v0.5;
[4]	FNP Process Specification 14-01-2010; DRAFT v0.4;
[5]	Central System Specification; 14-01-2010; DRAFT v0.4;
[6]	Resolution Procedure Specification for Bad Debt Subscribers; 14-01-2010; DRAFT version 0.3

Contents

1	Introduction.....	5
1.1	NP implementation in Bahrain	5
1.2	Number Portability (NP)	6
1.2.1	Definitions	6
2	Routing	7
2.1	Introduction.....	7
2.2	Routing for Mobile Ported Numbers.....	7
2.2.1	Definitions	7
2.2.2	General Principles.....	8
2.2.3	ETSI/3GPP Specifications.....	11
2.2.4	Routing mechanisms: ‘All Call Query’ and ‘Onward Routing’	12
2.2.5	Traffic Scenario’s MNP	13
2.3	Routing for FNP	32
2.3.1	General Principles.....	32
2.3.2	Traffic Scenario’s FNP	32
3	Charging.....	35
3.1	Introduction.....	35
3.2	Charging of porting transactions.....	35
3.3	Charging for calls to ported mobile numbers.....	35
3.3.1	Definitions	Error! Bookmark not defined.
3.3.2	General Principles.....	Error! Bookmark not defined.
3.3.3	Charging Scenario’s MNP	35
3.4	Charging of calls to ported Fixed Line numbers.....	40
3.4.1	General Principles.....	40
3.4.2	Charging scenario’s FNP	40
	Glossary	42

1 Introduction

This document is the specification of the routing and charging arrangements for number portability in the Kingdom of Bahrain.

1.1 NP implementation in Bahrain

Number portability will be introduced in the Kingdom of Bahrain in two phases:

Phase 1: Mobile Number Portability (MNP)

Phase 2: Full NP (including Fixed Numbers, Service Numbers, Universal Numbers, Short codes)

The Number Portability process is led by the Recipient Operator, which means that the Subscriber does not need to communicate with the Donor Operator. Communication between Recipient and Donor Operators will be managed through the Bahrain Number Portability System (BNPS). Details on the BNPS are referenced in the Central System Specification.

More details on the number portability process can be found in the Referenced Documents.

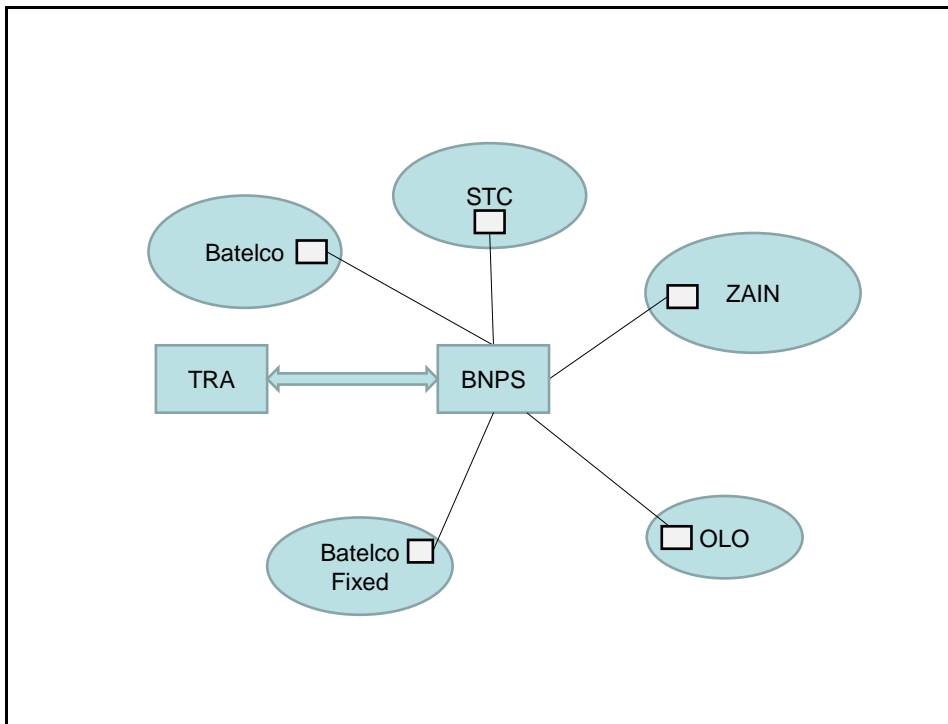

Figure 1. Centralized model where all messages pass through the BNPS

All Licensed Operators must be able to connect to the BNPS. All Licensed Operators have the potential to be involved in the number portability process as a Donor, Recipient or Block Operator, depending on the number ranges involved in the request. All Operators connected to the BNPS will be notified of any Number Porting requests that are ongoing or executed.

1.2 Number Portability (NP)

1.2.1 Definitions

Participants in the Number Portability (NP) process are Licensed Operators who are connected to the Central system for number portability. This Central System is also referred to as the Bahrain Number Portability System (BNPS).

The Licensed Operator to whom the number is being ported is referred to as RECIPIENT Network Operator (RECIPIENT). The Licensed Operator who is transferring the number to the RECIPIENT is referred to as DONOR Network Operator (DONOR). The Licensed Operator who is the original owner of a ported number-as it has been assigned the range, is referred to as BLOCK Operator (BLOCK OPERATOR). Once a number has ported then the RECIPIENT is further referred to as the Subscription Network. As the subscriber can be located on a visited network, the term Serving Network can be used in the context of a call.

Any other party involved in the mobile number portability process is referred to as 'other operator' or 'other participant' (OTHER).

A Service Provider is a reseller, using the SIM cards and Mobile Numbers of a Licensed Operator. The Licensed Operator will have to take care of the porting process as it is responsible towards TRA to meet the MNP regulation and is liable in case the reseller violates the regulation. The resellers will not have to be connected to the BNPS.

BNPS is transparent for these type of services providers. Registration and validation shall be based on the Licensed Operator networks hosting the Service Provider.

MTA means Mobile Terminating Access Fee

FTA means Fixed Terminating Access Fee

2 Routing

2.1 Introduction

This chapter specifies the arrangements of call routing to Ported Numbers. The Licensed Operators need to implement a number of technical facilities, including the following:

1. Routing mechanisms
2. Signaling: agreement on the SCCP version, addressing and translation types used between networks (in case SS7 is applied)
3. Voice interconnects: transfer of the network routing number in the ISUP IAM (in case of circuit switched traffic)
4. Portability process, specified in Referenced Document [3]

This document does not aim to describe specific implementations on the Licensed Operator side regarding the NP database and how lookups are performed, as different solutions are possible such as:

- a. Intelligent Network (IN)
- b. Signaling Relay Functions (SRF)
- c. Special routing functions, Flexible Number Routing.

2.2 Routing for Mobile Ported Numbers

2.2.1 Definitions

Once a porting process has been finalized, then the RECIPIENT operator becomes the Subscription Network.

A Licensed Operator terminating traffic to another Licensed Operator's network is referred to as the Originating Network and Destination Network, respectively. Licensed Operators carrying traffic between the Originating Network and Destination Network are referred to as the Transit Network.

NP Lookup: action where a network looks up a called number in a database, in order to identify the Subscription network being either:

- 1) the terminating or originating network itself
- 2) Original number holder (BLOCK Operator)
- 3) Ported-to network

All Call Query (ACQ): when a Licensed Operator performs NP lookups for every originated call, in order to be able to directly route a call to the Subscription Network

Onward Routing (OR): when a Licensed Operator does not perform NP lookups for every originated call, but only performs lookups for received calls from other networks (for example from abroad) for which the Originating Network did not perform a NP Lookup and subsequently 'onward routes' the call to the Subscription network. This can be performed by the BLOCK Operator – to whom the call will be routed based on the number range- or by a transit operator as a service.

Routing Number (RN): a number which is looked up in a NP database/SRF, indicating the network to which the phone number belongs or has been ported. This RN can be prefixed to the called number (NSN or MSISDN) for:

- Routing to the Subscription Network
- Indicating that a NP check has already been performed. This implies that following a NP lookup the RN shall always be added, even if the number has not been ported.

A Transit Network will not modify the RN. The Destination Network receiving a call with RN included shall not modify the RN, but it shall release the call if the subscriber is not active on this network.

2.2.2 General Principles

Each Licensed Operator shall route calls to ported numbers in a most efficient way. Licensed Operators shall route calls to the Subscription network, when it receives calls from networks which have not performed NP lookups for the Bahrain phone numbers. These networks can be foreign networks terminating traffic, though there is no restriction on foreign networks to maintain a Number Portability database with Bahrain numbers.

Although several techniques can serve the same goal, it is necessary –in order to avoid incompatibility issues or call loops- that the voice (ISUP) and signaling (SCCP) interfaces between operators are specified.

Applicable Interfaces for routing between the Licensed Operators:

- voice (ISUP)
- Signaling (SCCP/MAP) for SMS and other non-call related signaling
- MMS (MM4)

Voice

The general principle is that all Licensed Operators shall perform Number Portability lookups when:

1. Licensed Operator's customer places (originates) a call
2. Licensed Operator receives a call from another network which has not performed a NP lookup.

1) This is also referred to as **All Call Query (ACQ)**. If the Called Party is ported from the original operator (BLOCK Operator) to a new Subscription network, then the call to the National Significant

Number (NSN) shall be directly routed to the Subscription network by including a Routing Number (RN) in the ISUP-IAM message, also noted as: RN+NSN.

“Directly” in this context means that the call will not be routed to the BLOCK Operator first. The call may however pass a transit operator (see Ad 2).

If the Called party is not ported then the call shall be routed to the BLOCK Operator, also with the NSN prefixed with RN in the IAM.

The Licensed Operator receiving an ISUP-IAM with RN, shall not modify the RN. In case the RN refers to its own network (does not act as transit) and the subscriber is not connected on this network, then the call shall be released.

The call may also be destined for the licensed Operator’s own customers (onnet call). In these cases it is up to the operator how to route the calls and handle the ISUP-IAM.

2) A Licensed Operator may receive a call from another network. These calls can be destined for the Licensed Operator’s own customers (terminating traffic) or are destined to another Licensed Operator (transit traffic).

In case the call is - according to the RN - destined for the Licensed Operator’s customers, but the routing number is incorrect then the call shall be dropped. This measure prevents call loops in case the terminating network’s SRF/NP database indicates that the number belongs to the originating network.

In case of transit, the transiting network is fully transparent regarding the RN provided by the originating network. Even if RN seems to be wrong according to the SRF/NP database, then the call will be routed to the destination by RN.

If the call does not contain a RN, then the Licensed Operator shall perform a check on the SRF/Number Portability database to check the corresponding network. The following situation can occur:

- a. call is routed by number range and Licensed Operator is BLOCK Operator. The BLOCK Operator terminates the call to its subscriber.
- b. call is routed by number range and Licensed Operator is BLOCK Operator but number has ported out. The BLOCK Operator shall act as a Transit Network and the call shall be routed to the Subscription Network. This is also referred to a **Onward Routing (OR)**. The NP database holds all Bahrain ported numbers- not only its own out ported numbers, enabling the Licensed Operator to include the correct RN directly in the ISUP-IAM without having to take measures for subsequent porting (relaying SRI messages or modifying RN’s).
- c. call is offered for Transit. The transit operator will perform Onward Routing for to the Subscription Networks. Whether calls are ported or still with their BLOCK Operator, a RN will be included.

SMS

For SMS the same principle is applicable, but the protocols are different (MAP) from voice (ISUP). After a subscriber has submitted a SMS towards the SMS-C, then the SMS-C shall perform the MAP operation Send Routing Info for Short Message (SRI_SM) to the HLR. An intermediate step however is to check the SRF/number portability database if the number has been ported(ACQ). If the number has been ported then the MAP message SRI_SM shall be sent to the Subscription network's HLR (instead of BLOCK Operator) with RN+MSISDN. The Subscription network's HLR shall answer the originating network's SMS-C with information on where to route the SMS (visited MSC, corresponding IMSI).

If a Licensed Operator receives a SRI_SM (no RN) but the customer has been ported out, then it shall onward route the SRI to the Subscription network according to the NP lookup (RN+MSISDN).

If a SRI_SM has been routed to the wrong Destination Network (RN not correct) then the RN shall not be modified but an acknowledgement will be sent back that the subscriber is unknown. This is analogue to the solution for voice (drop the call) to prevent loops.

Other Signaling

If a Licensed Operator (BLOCK Operator in these cases) receives other signaling destined for a subscriber that has been outported (e.g. SRI for Optimal Routing , Call Completion for Busy Subscriber or CAMEL message Any Time Inquiry) then the messages shall be onward routed to the Subscription network.

MMS

There are no NP arrangements for the MM4 interface, assuming the originating MMS-C makes use of the MAP signaling messages SRI_SM or Send_IMSI to find the corresponding Subscription network by Mobile Country Code and Mobile Network Codes (MCC MNC).

Transit

In above context 'direct routing' may still take place via a transit operator if no direct interconnects are in place. The different scenario's are depicted in Figure 2.

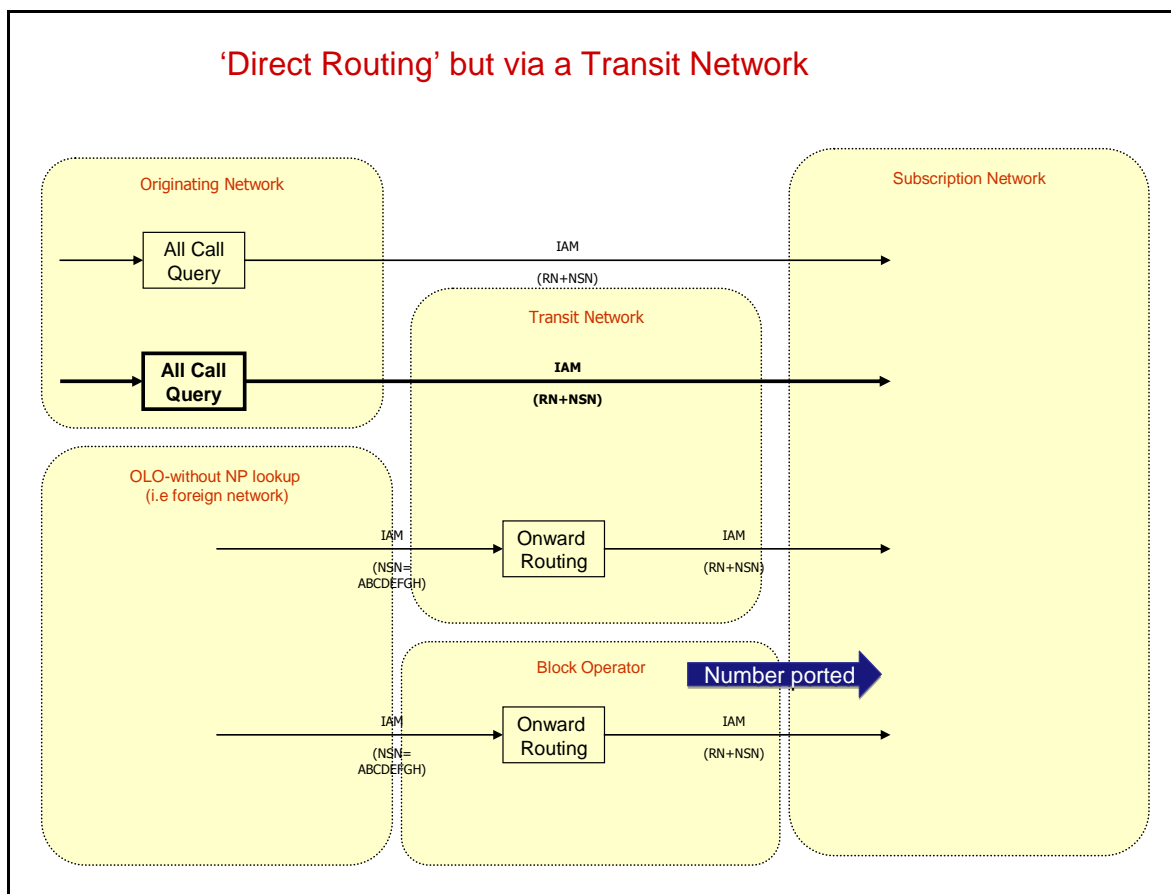

Figure 2. 'Direct Routing' via a Transit Network

2.2.3 ETSI/3GPP Specifications

The following specifications in detail describe the 'All Call Query' and 'Onwards Routing' mechanism, as well as possible technical implementations on the Operator's side and make reference to specifications explaining in more detail the impact on MAP and ISUP fields:

- ETSI TS 122 066 V4.0.0 (2001-03) Digital cellular telecommunications system (Phase 2+) (GSM); Universal Mobile Telecommunications System (UMTS); Support of Mobile Number Portability (MNP); Service description; Stage 1 (3GPP TS 22.066 version 4.0.0 Release 4)
- ETSI TS 123 066 V4.0.0 (2001-03) TS Digital cellular telecommunications system (Phase 2+) (GSM); Universal Mobile Telecommunications System (UMTS); Support of Mobile Number Portability (MNP); Technical Realisation; Stage 2 (3GPP TS 23.066 version 4.0.0 Release 4)

The MMS scenario's follow the following specification:

- 3GPP TS 23.140 V6.16.0 (2009-03) Technical Specification 3rd Generation Partnership Project; Technical Specification Group Core Network and Terminals; Multimedia Messaging Service (MMS); Functional description; Stage 2(Release 6)

This Routing and Charging document is leading for the implementation of Charging and Routing principles in the Kingdom of Bahrain. It is based on the routing principles defined in the abovementioned ETSI specifications.

2.2.4 Routing mechanisms: 'All Call Query' and 'Onward Routing'

Figure 3 and Figure 4 depict the ACQ and OR routing mechanisms. As explained in chapter 2.2.2, in practice Licensed Operators shall use a combination of both ACQ and OR.

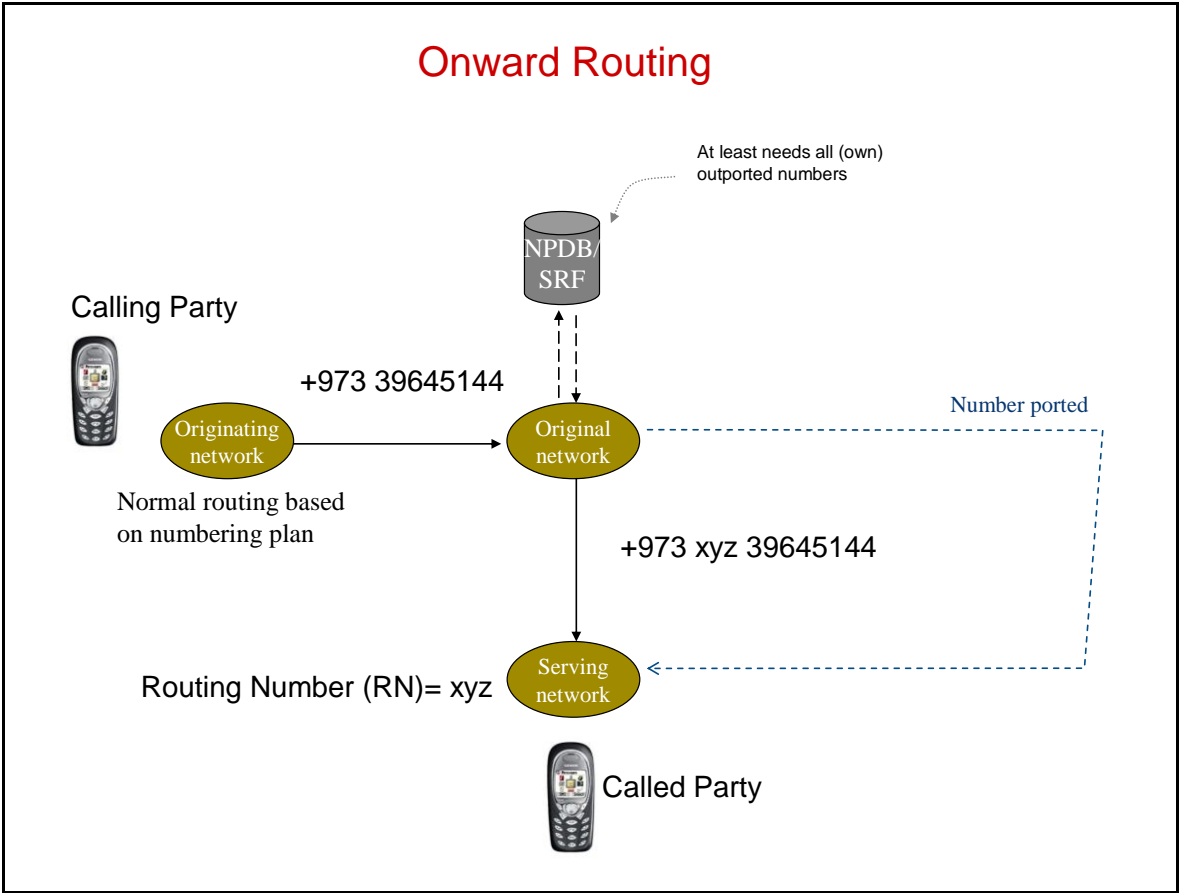

Figure 3 – Onward Routing (OR)

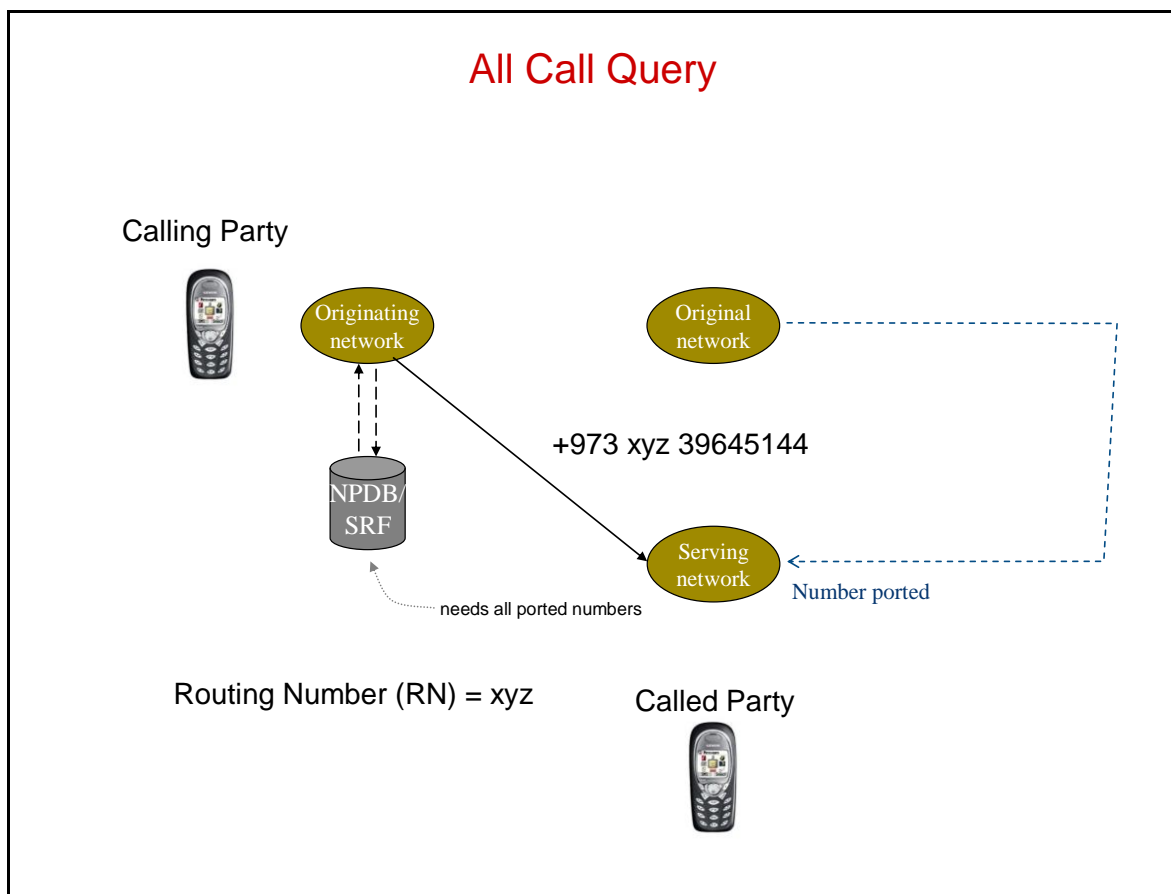

Figure 4 – All Call Query (ACQ)

2.2.5 Traffic Scenario's MNP

Below are depicted the different traffic scenario's. Note that in cases where is stated 'no lookup as RN already included', there is in fact no objection to NP lookups for (internal) means as long as the Operator shall not modify the RN for onward routing.

2.2.5.1 Traffic Scenario's MNP- voice

Note:

All scenario's where is stated "No NP lookup as RN already included" means that the RN shall not be modified on the ISUP interface as NP lookup has already been done by the Originating Network. This specification does not aim to limit the Licensed Operator on their internal implementation (i.e. whether or not a SRF/NPDB is used or not to find a corresponding HLR etcetera).

If the number is not connected on the Destination Network, then again no modification of the RN takes (given that the destination network has a different RN registered in its NPDB/SRF) place but the call is released. These situations however should lead to an operational procedure to solve the inconsistency that exists between the origination and destination network.

The reason not to change the RN in the destination network is to prevent ‘circular routing’ of calls.

In addition to this measure (or possibly as an alternative measure) network operators are advised to analyze and implement functions for ‘looping prevention’.

Traffic scenario 1c (Figure 7 - on-net call) - is an example and is included for completeness. This document does not aim to set rules for the Licensed Operator on how/if to perform NP lookups nor on how to route these calls (whether an RN should be used or not).

For scenario 3a (Figure 10) and scenario 3b (Figure 11), a foreign network terminating traffic is chosen as an example for a network which has no NP lookup facility. However, there is no legal or technical restriction to prevent a foreign operator to hold a NP database with Bahrain numbers and directly route calls accordingly.

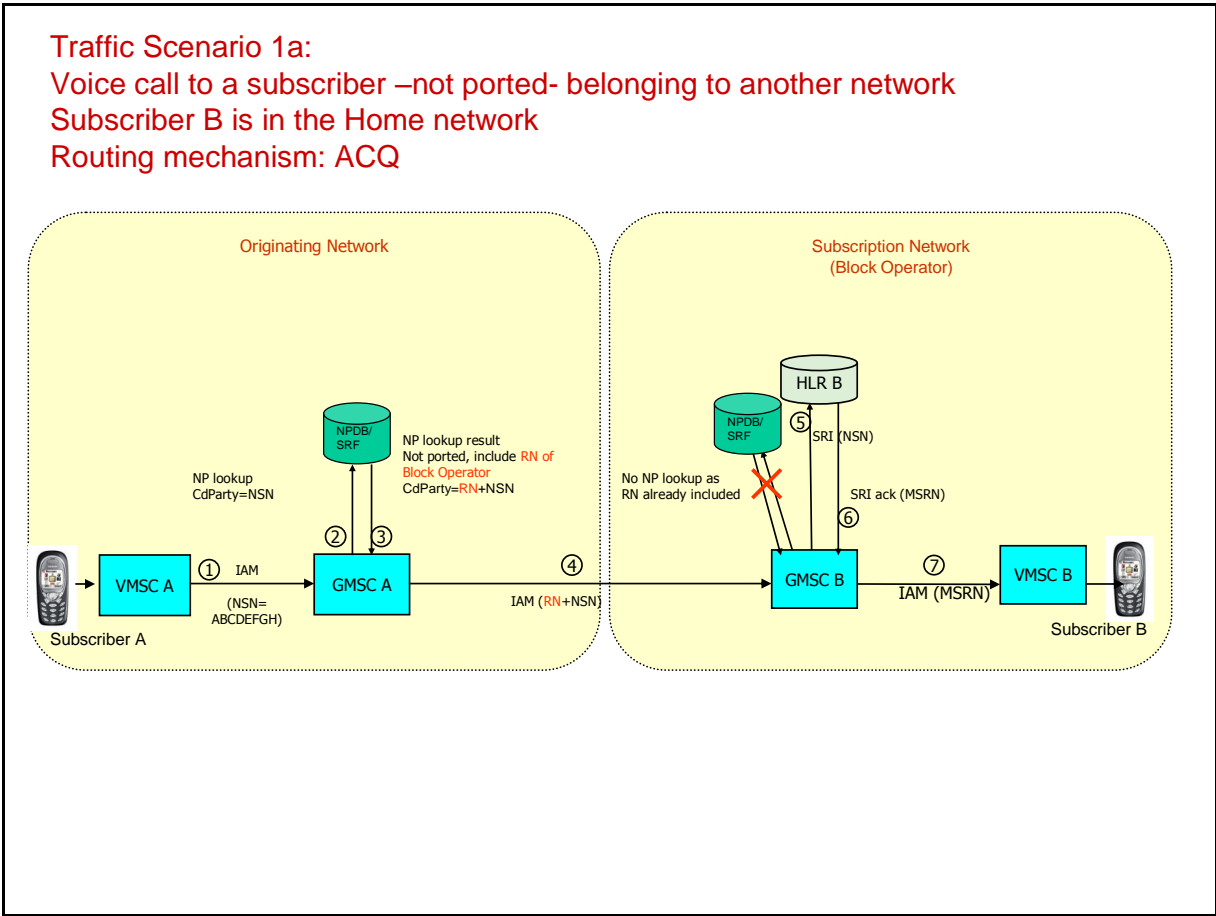

Figure 5. Voice call to a non-ported subscriber in another network-non roaming

Traffic Scenario 1b:
 Voice call to a customer –not ported- belonging to another network
 Subscriber B is roaming
 Routing mechanism: ACQ

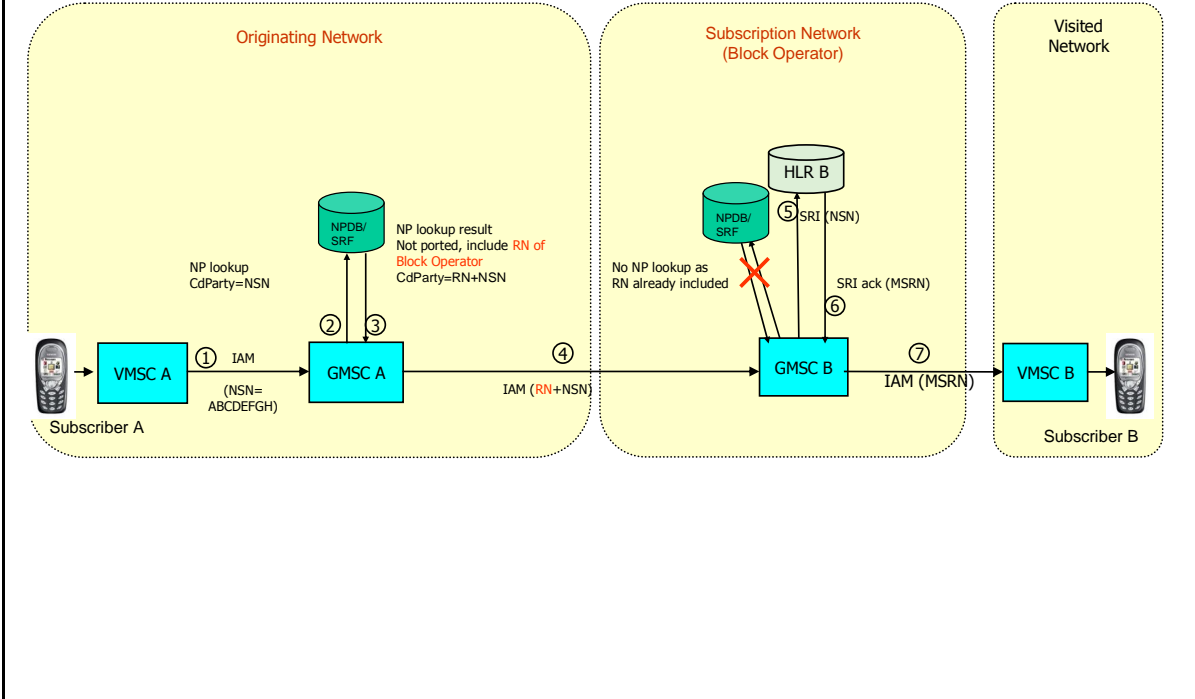

Figure 6. Voice call to a non-ported subscriber in another network- roaming

Traffic Scenario 1c:
 Voice call to a customer –not ported- belonging to the same network (onnet)
 Subscriber B is in the home network
 Routing mechanism: ACQ

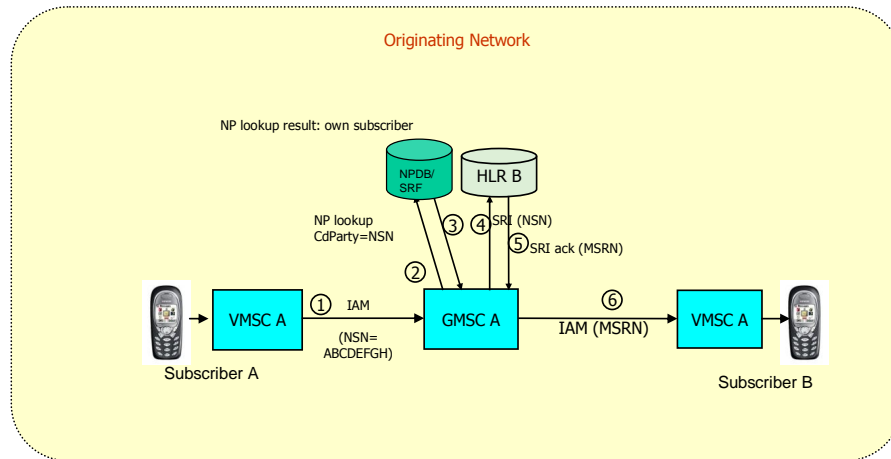

Figure 7. Voice call to a non-ported subscriber in the same network (on-net)

Traffic Scenario 2a:
 Voice call to a subscriber –ported- belonging to another network
 Subscriber B is in the Home network
 Routing mechanism: ACQ

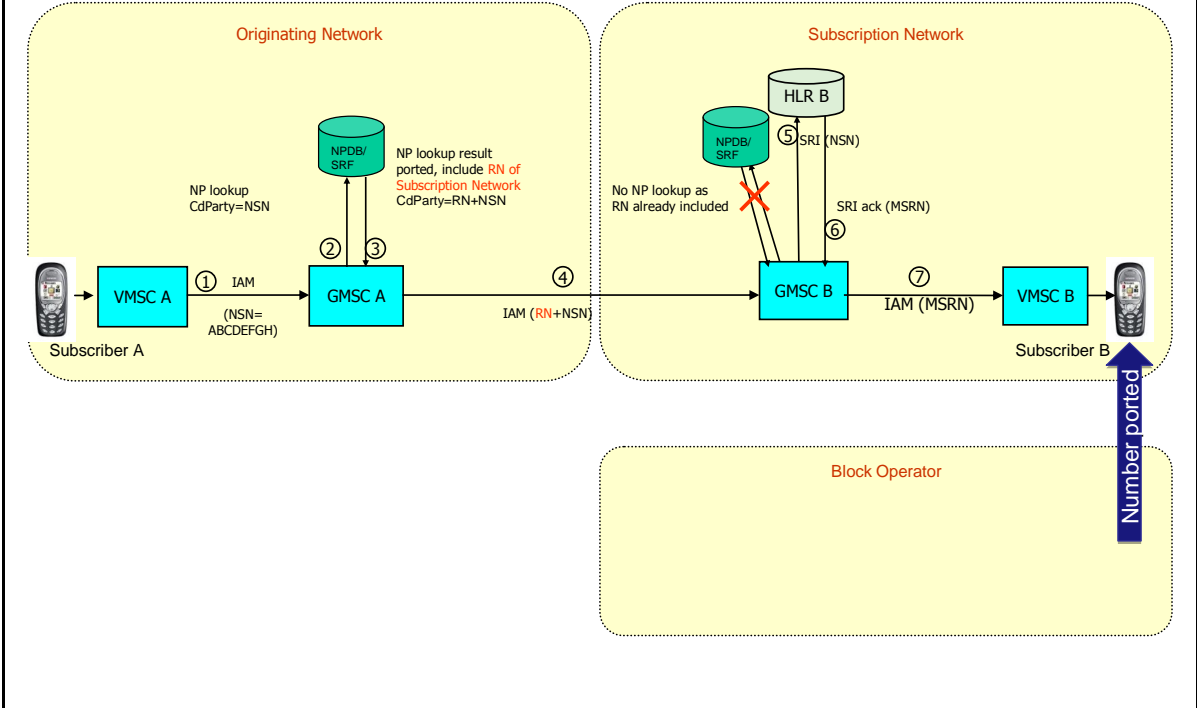

Figure 8. voice call to a ported number(ACQ) in another network - non roaming

Traffic Scenario 2b:
Voice call to a subscriber –ported- belonging to another network
Subscriber B is roaming
Routing mechanism: ACQ

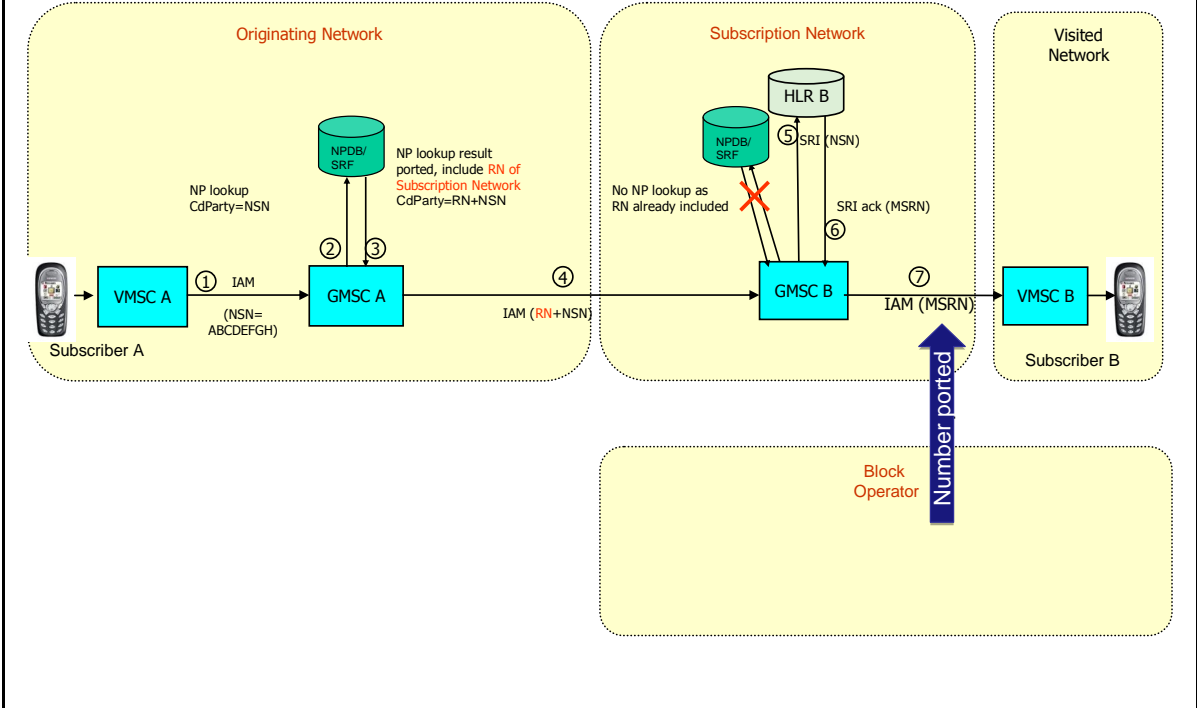

Figure 9. voice call to a ported number (ACQ)in another network- roaming

Traffic Scenario 3a:
 Voice call to a subscriber –ported- belonging to another network
 Subscriber B is in the Home network
 Routing mechanism: OR

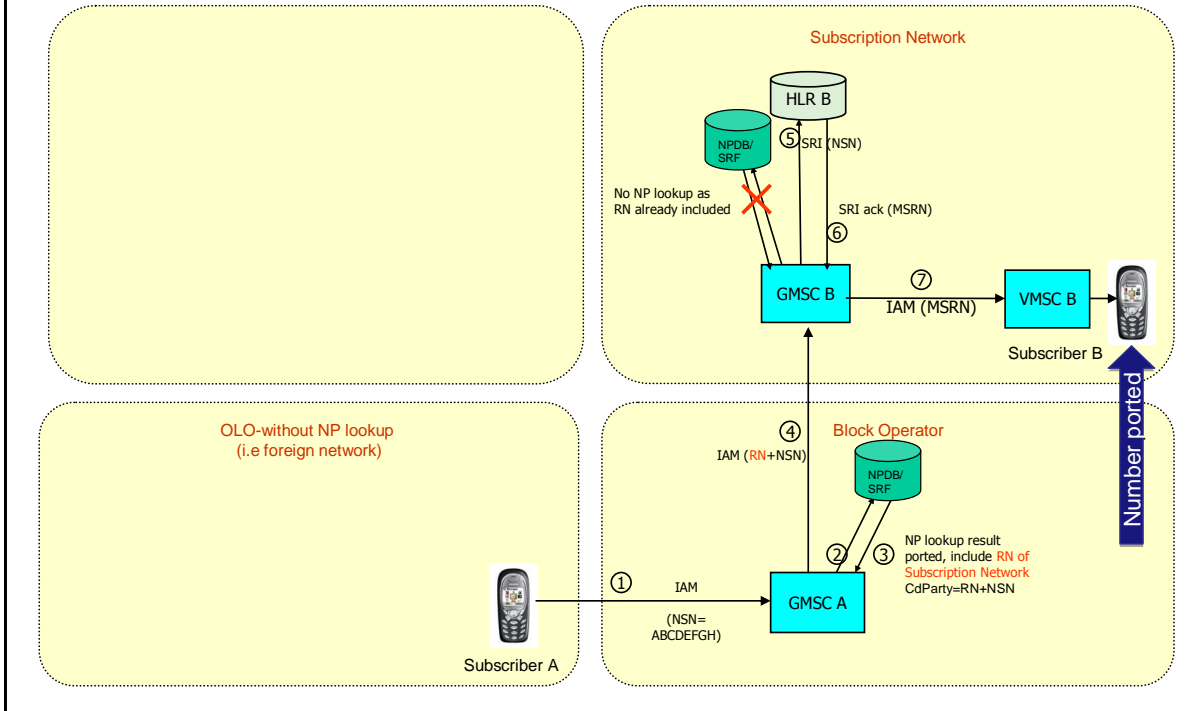

Figure 10. voice call to a ported number (OR) in another network-non roaming

Traffic Scenario 3b:
 Voice call to a subscriber –ported- belonging to another network
 Subscriber B is roaming
 Routing mechanism: OR

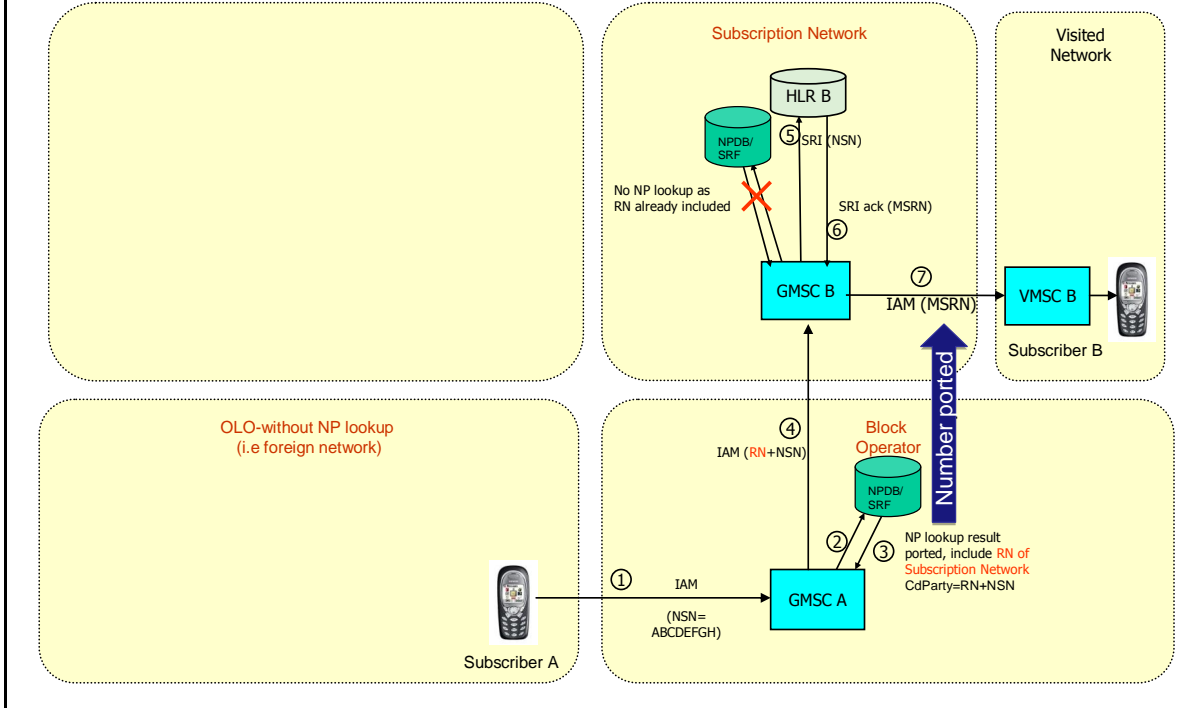

Figure 11. voice call to a ported number (OR) in another network-roaming

2.2.5.2 Traffic scenario's MNP- SMS Signaling

Note: Traffic scenario 4c (Figure 14, on-net SMS) is an example and is included for completeness. This document does not aim to set rules for the Licensed Operator on how/if to perform NP lookups for these calls nor on how to route these calls, for example whether or not a RN should be used.

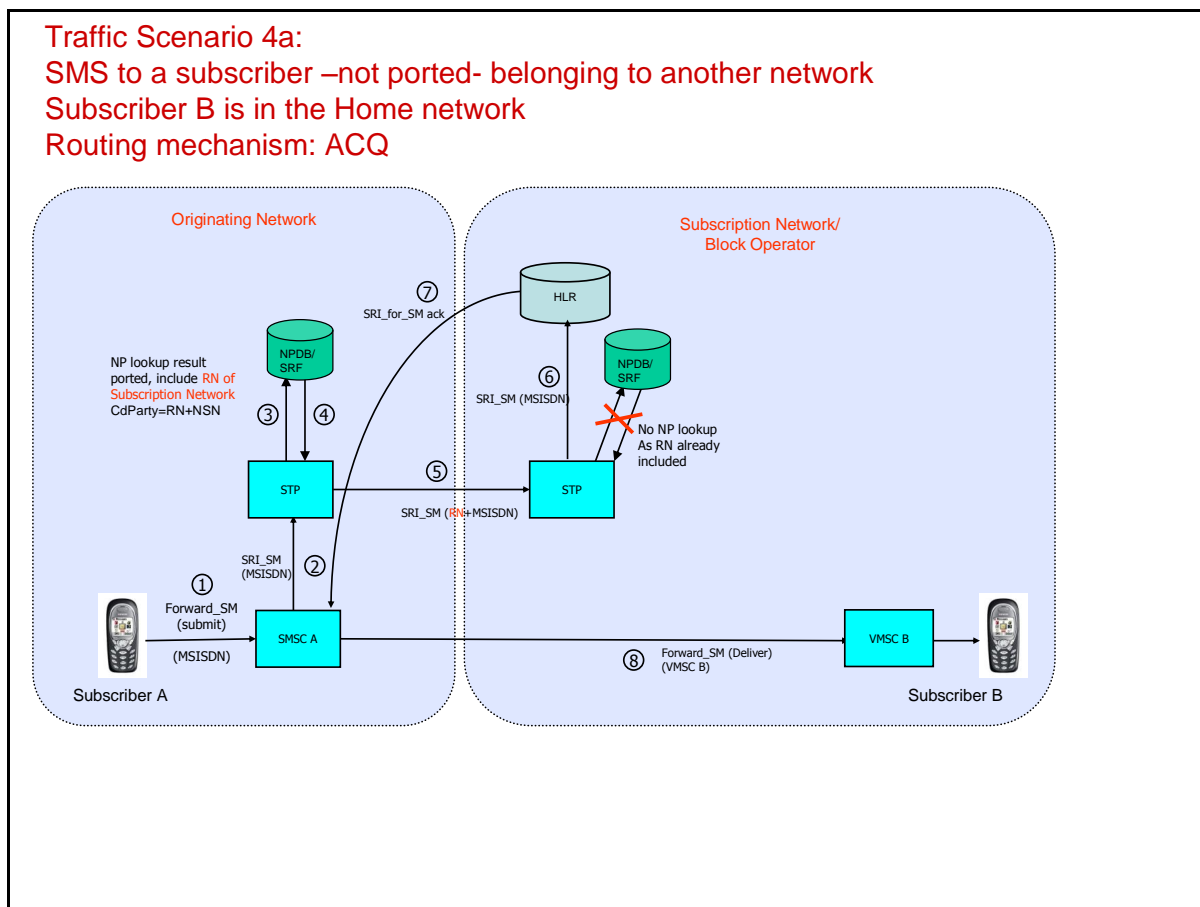

Figure 12. SMS to non-porting number in another network – non roaming

Traffic Scenario 4b:
SMS to a subscriber –not ported- belonging to another network
Subscriber B is roaming
Routing mechanism: ACQ

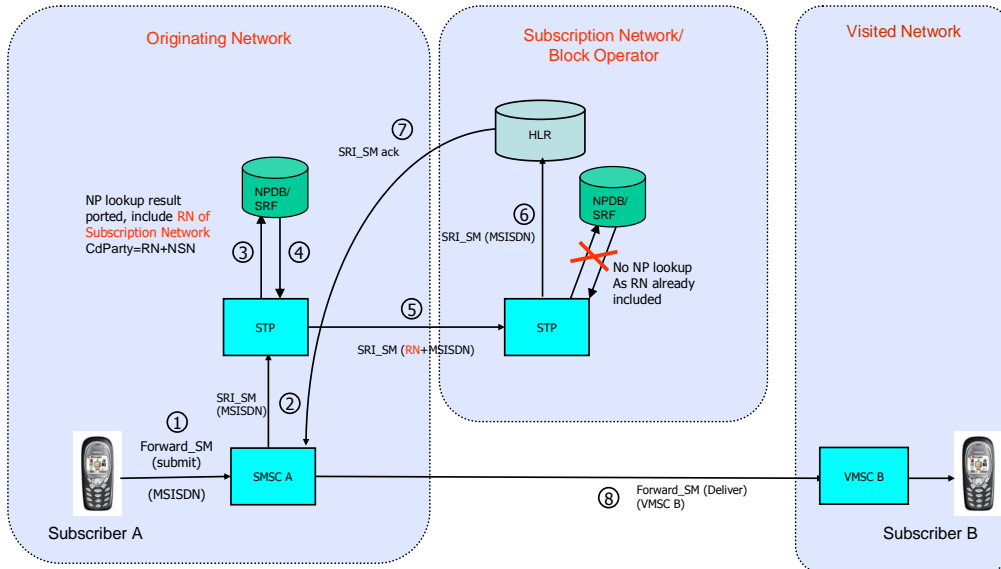

Figure 13. SMS to non-ported number in another network – roaming

Traffic Scenario 4c:
 SMS to a subscriber –not ported- belonging to the same network (onnet)
 Subscriber B is in the home network
 Routing Mechanism: ACQ

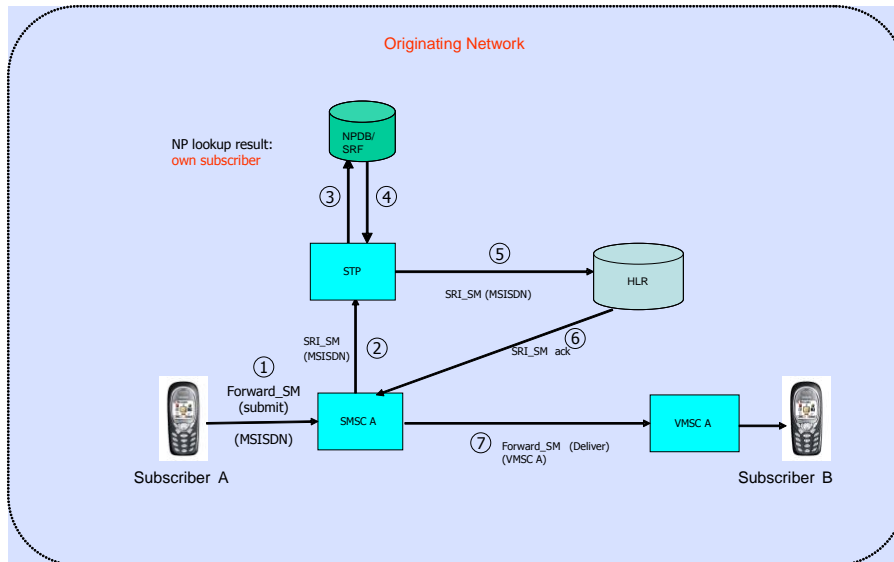

Figure 14. SMS to non-ported number on the same network (on-net)

Traffic Scenario 5a:
 SMS to a subscriber –ported- belonging to another network
 Subscriber B is in the Home network
 Routing mechanism: ACQ

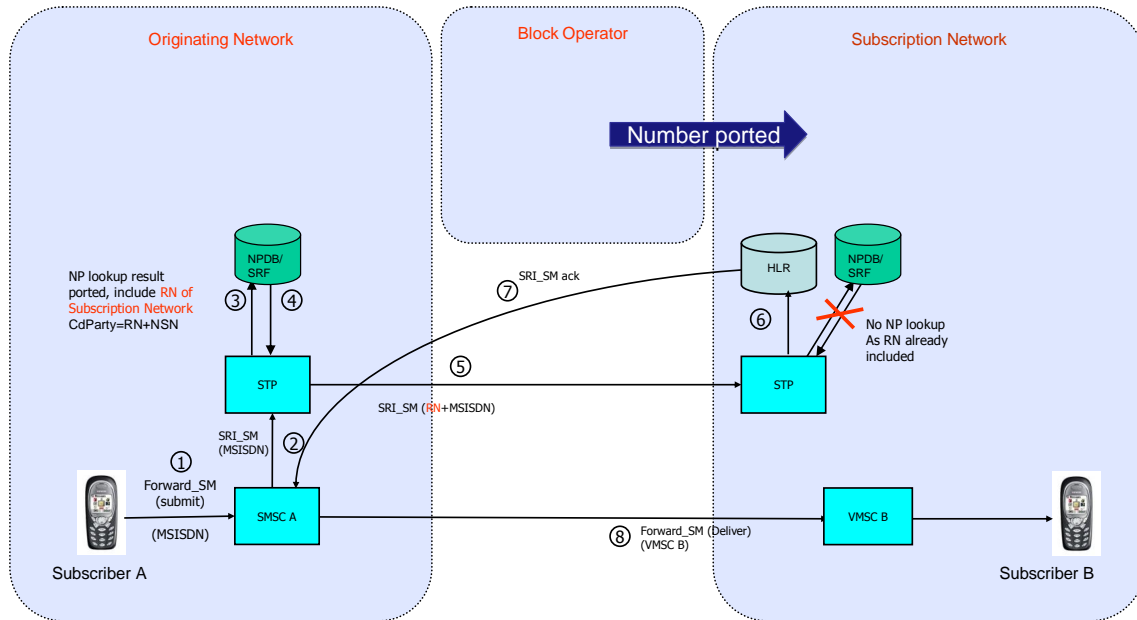

Figure 15. SMS to ported number (ACQ) on another network- non roaming

Traffic Scenario 5b:
 SMS to a subscriber –ported- belonging to another network
 Subscriber B is roaming
 Routing mechanism: ACQ

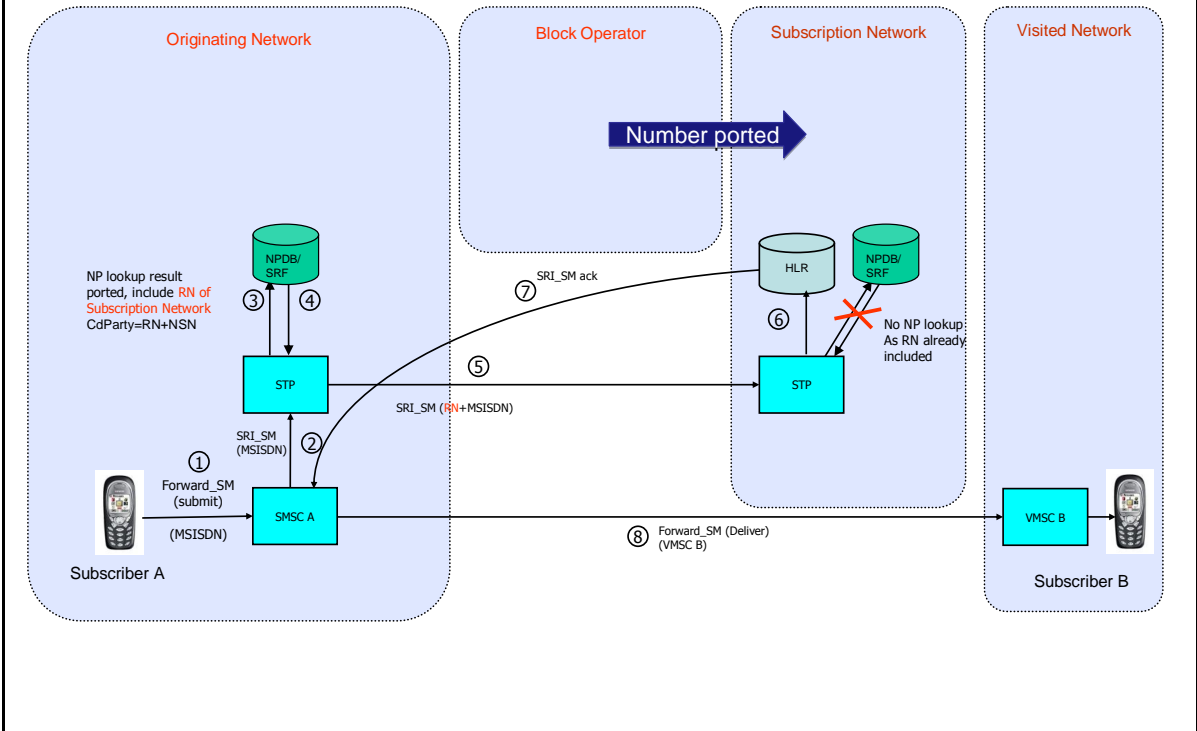

Figure 16. SMS to ported number (ACQ) on another network- roaming

Traffic Scenario 6a:
 SMS to a subscriber –ported- belonging to another network
 Subscriber B is in the Home network
 Routing mechanism: OR

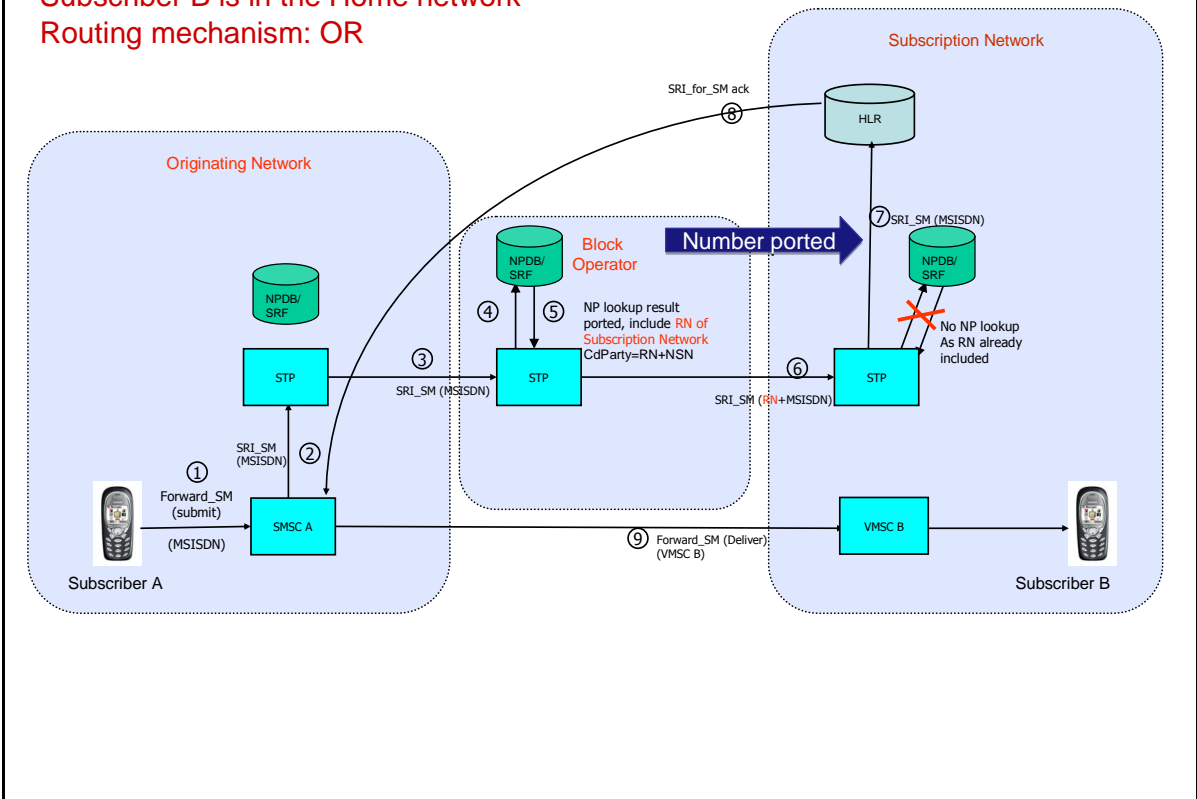

Figure 17. SMS to ported number (OR) on another network- non roaming

Traffic Scenario 6b:
 SMS to a subscriber –ported- belonging to another network
 Subscriber B is roaming
 Routing mechanism: OR

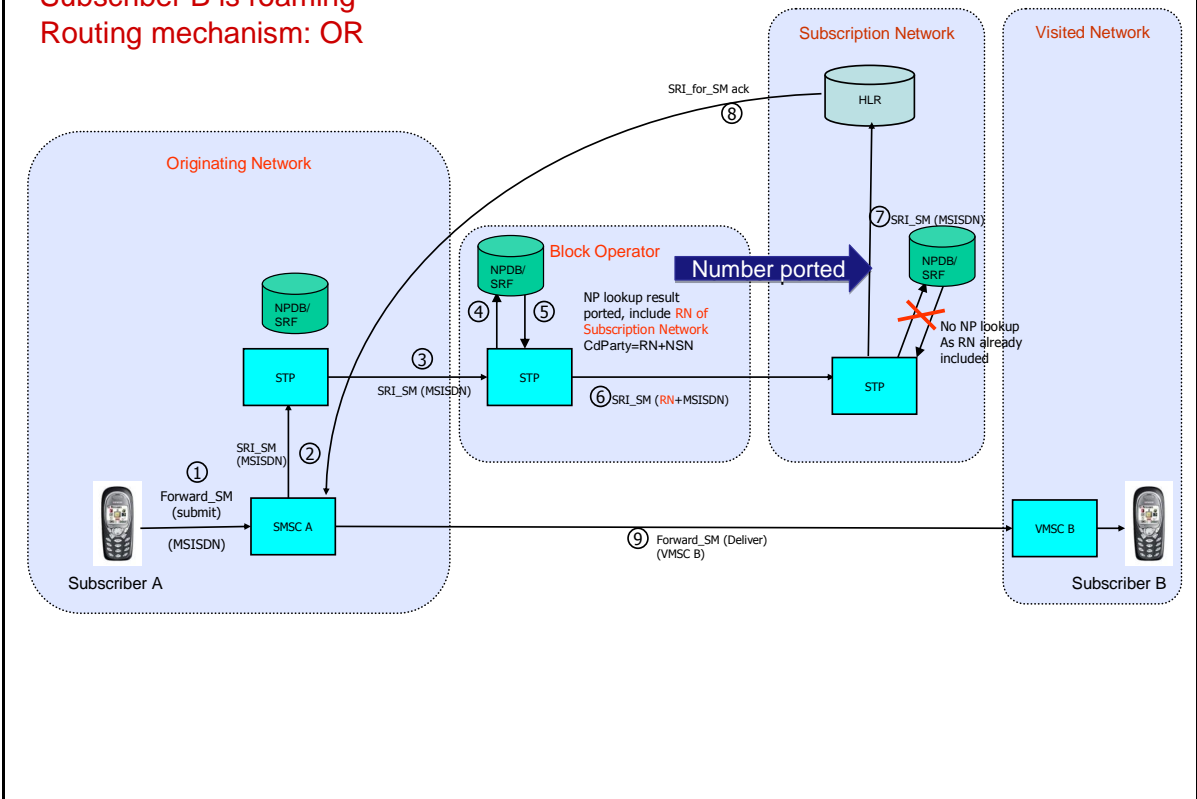

Figure 18. SMS to ported number (OR) on another network- roaming

2.2.5.3 Traffic scenario's MNP- other signaling

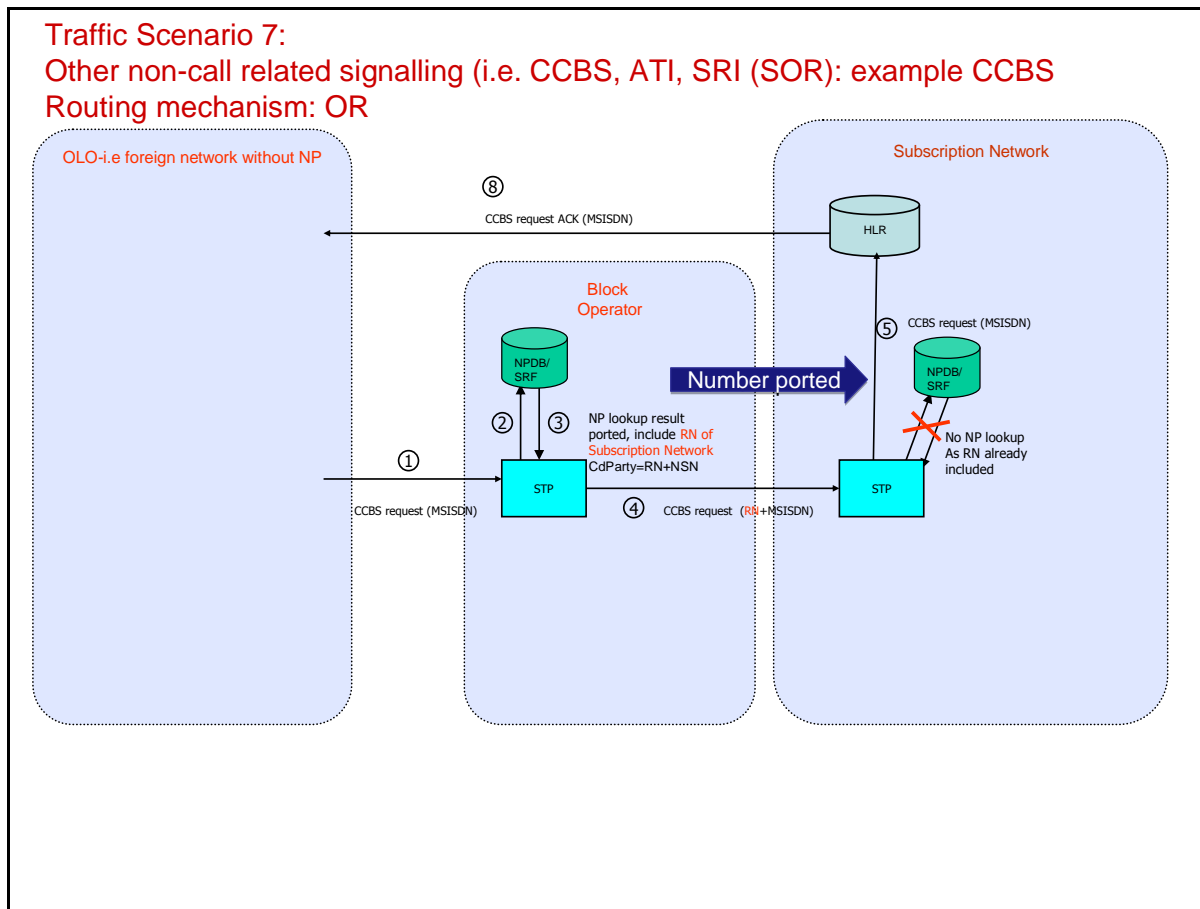

Figure 19. other signaling to ported numbers (OR)

2.2.5.4 Traffic scenario's MNP - MMS to ported to mobile numbers

There are no NP arrangements for the MM4 interface, like onward routing. MMS uses the SMS MAP message SRI_SM to resolve the corresponding network (Subscription Network) by IMSI. The first 5 digits (6 in North America) are the Mobile Country Code (MCC) and Mobile Network Code (MNC). These are in turn used to resolve the Subscription Network's MMS-C IP address.

Alternatively the MAP operation SEND_IMSI can be used.

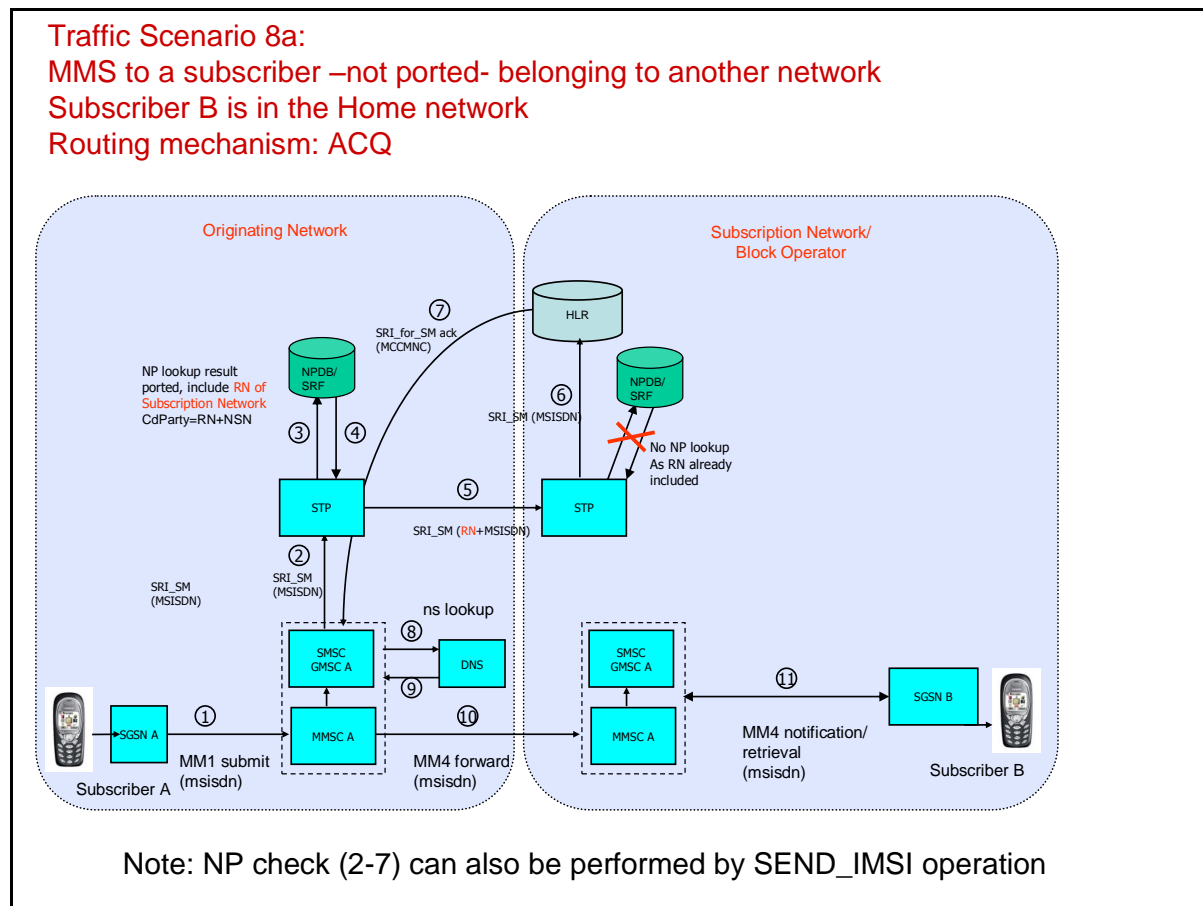

Figure 20. MMS to non-ported numbers in another network- non roaming

Traffic Scenario 8b:
MMS to a subscriber –ported- belonging to another network
Subscriber B is in the Home network
Routing mechanism: ACQ

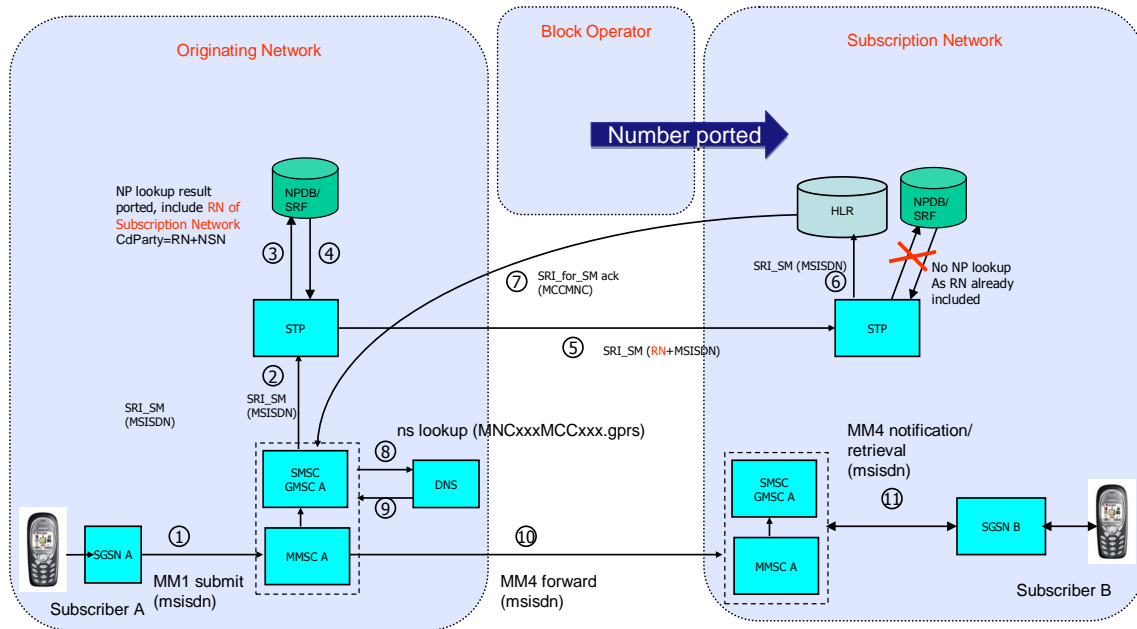
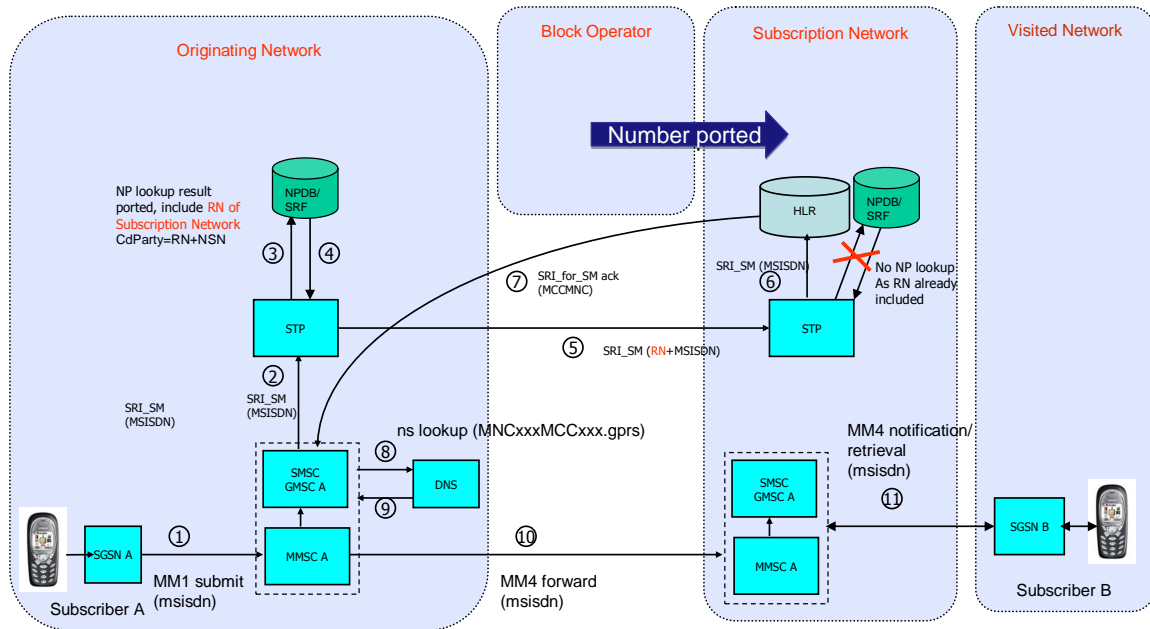

Figure 21. MMS to a ported number in another network - non roaming

Traffic Scenario 8c:
MMS to a subscriber –ported- belonging to another network
Subscriber B is roaming
Routing mechanism: ACQ



Note: NP check (2-7) can also be performed by SEND_IMSI operation

Figure 22. MMS to a ported number in another network-roaming

2.3 Routing for FNP

2.3.1 General Principles

For cases where circuit switching and ISUP signaling are applied for interconnection between networks, the traffic scenarios for FNP are similar to the MNP scenarios. However it should be noted that:

- 1) The terminology for certain network components like GMSC or VMSC does not exist in fixed networks;
- 2) SMS/MMS does not apply;
- 3) The terminating Subscriber is not capable of roaming in a visited network (internationally) as is the case for mobile networks.
- 4) Signaling internally within the fixed network is most likely not SS7 signaling but Session Initiation Protocol (SIP), where SIP URI are used instead for routing.

For cases where IP interconnections may be applied (using SIP) the SIP URI should identify to which subscription network a call should be routed e.g. if the number 12345678 is ported from network A to network B, then instead of applying the routing number for network B, a SIP URI such as 12345678@sip.networkb.bh should be applied, that unambiguously directs the call to the ported subscriber in the subscription network. In this example the Routing Number provided by the BNPS to the origination network (and stored in the local NP database of Network A) should be uniquely translated to a corresponding SIP URI. This solution can only work in case each SIP URI address in the destination network is adhering to a fixed format such as in the above example.

Optionally the RN number could be added to the NSN part in the SIP URI in order to make known to the destination network that a NP look up took place at the origination, so that the destination network will not 'reroute' the call in case it has conflicting Routing and NP information in its own network. This would prevent 'looping' or 'circular routing' as in the circuit switching technology.

2.3.2 Traffic Scenario's FNP

In the next figures not every possible scenario is depicted. Two examples are given:

- 1) (Figure 23) Call to a ported Fixed Line subscriber- directly routed to the Subscription network by All Call Query Mechanism
- 2) (Figure 24) Call to a ported Fixed Line subscriber- onward routing to Subscription network by BLOCK operator

Traffic Scenario 9a:
Call to a Fixed Line subscriber –ported- belonging to another network
Routing mechanism: ACQ

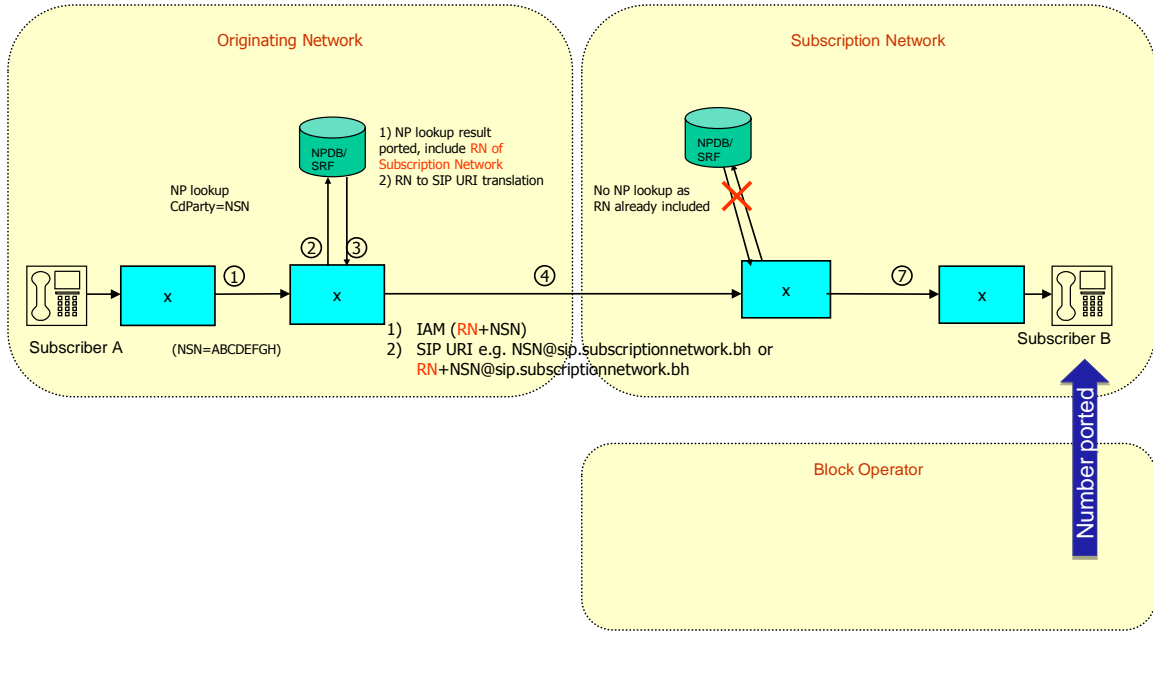

Figure 23. Call to ported Fixed Line subscriber (ACQ)

Traffic Scenario 9b:
 Call to a Fixed Line subscriber –ported- belonging to another network
 Routing mechanism: OR

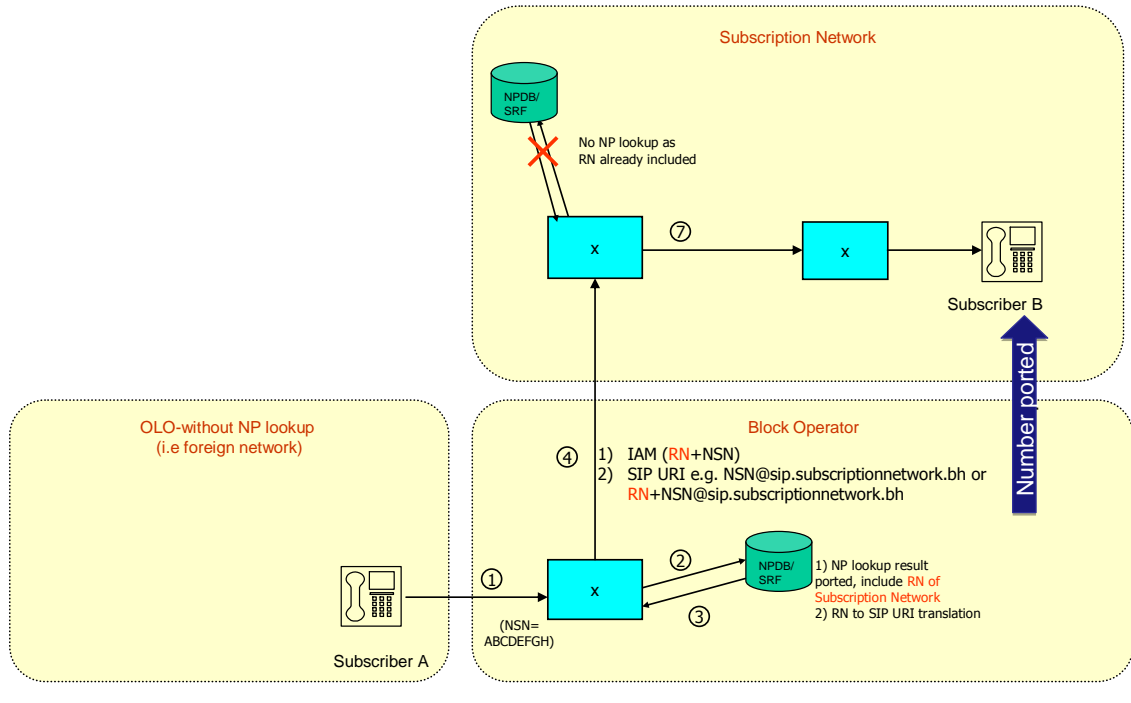

Figure 24. Call to ported Fixed Line subscriber (OR)

3 Charging

3.1 Introduction

This chapter specifies the charging aspects

3.2 Charging of porting transactions

Licensed Operators will bear the costs involved with setting up Number Portability processes and IT/Network investments.

Charging for number portability is explained in the Number Portability Regulation Document.

3.3 Charging for calls to ported mobile numbers

3.3.1 Charging Scenario's MNP

3.3.1.1 Charging scenario MNP – voice

The charges between operators for handling calls are handled via Interconnect and Roaming agreements and are not subject to MNP specification. However, for the sake of clarity the most important scenario's have been depicted in the following Figures.

Charging for Traffic Scenario 2a

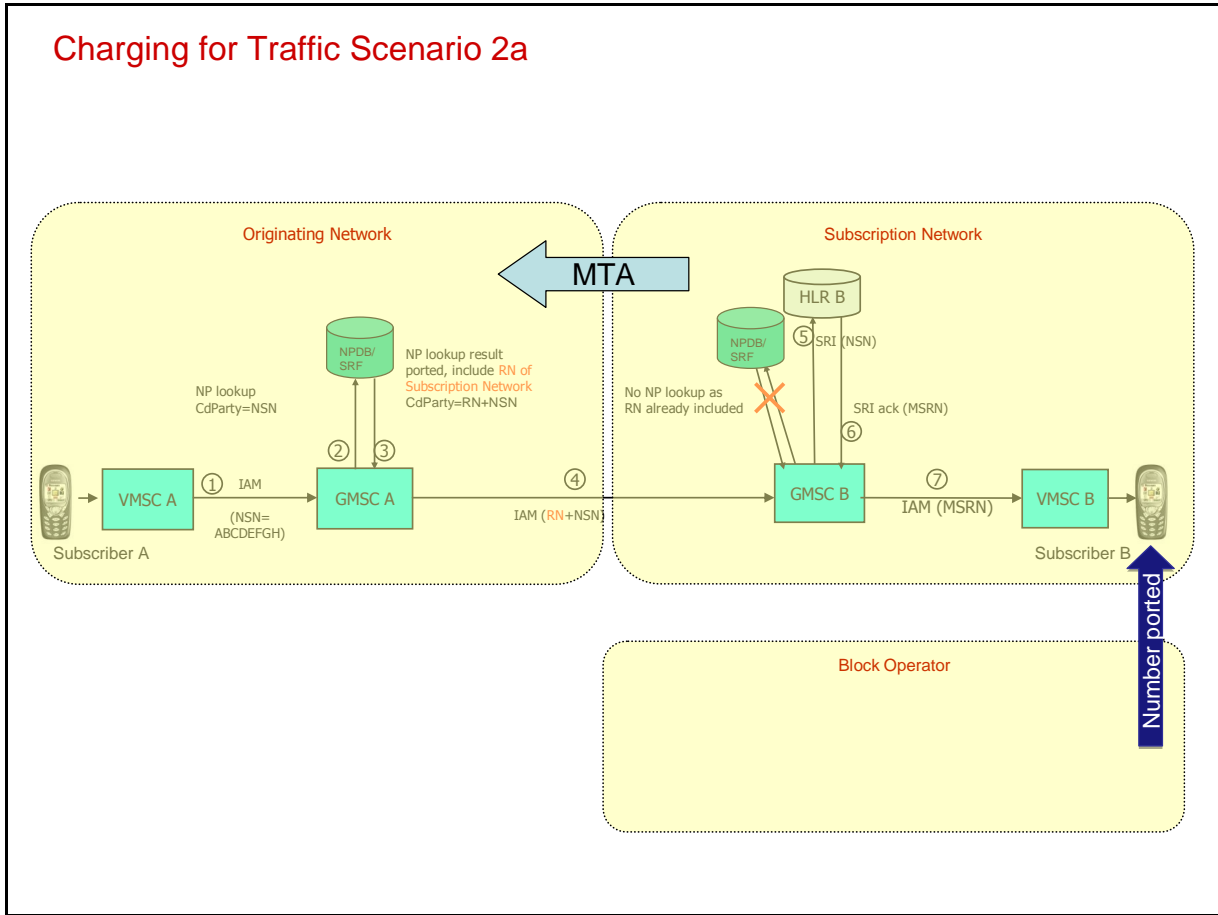

Figure 25. Interconnect settlement for calls to ported number (ACQ) – non roaming

Charging for Traffic Scenario 2b

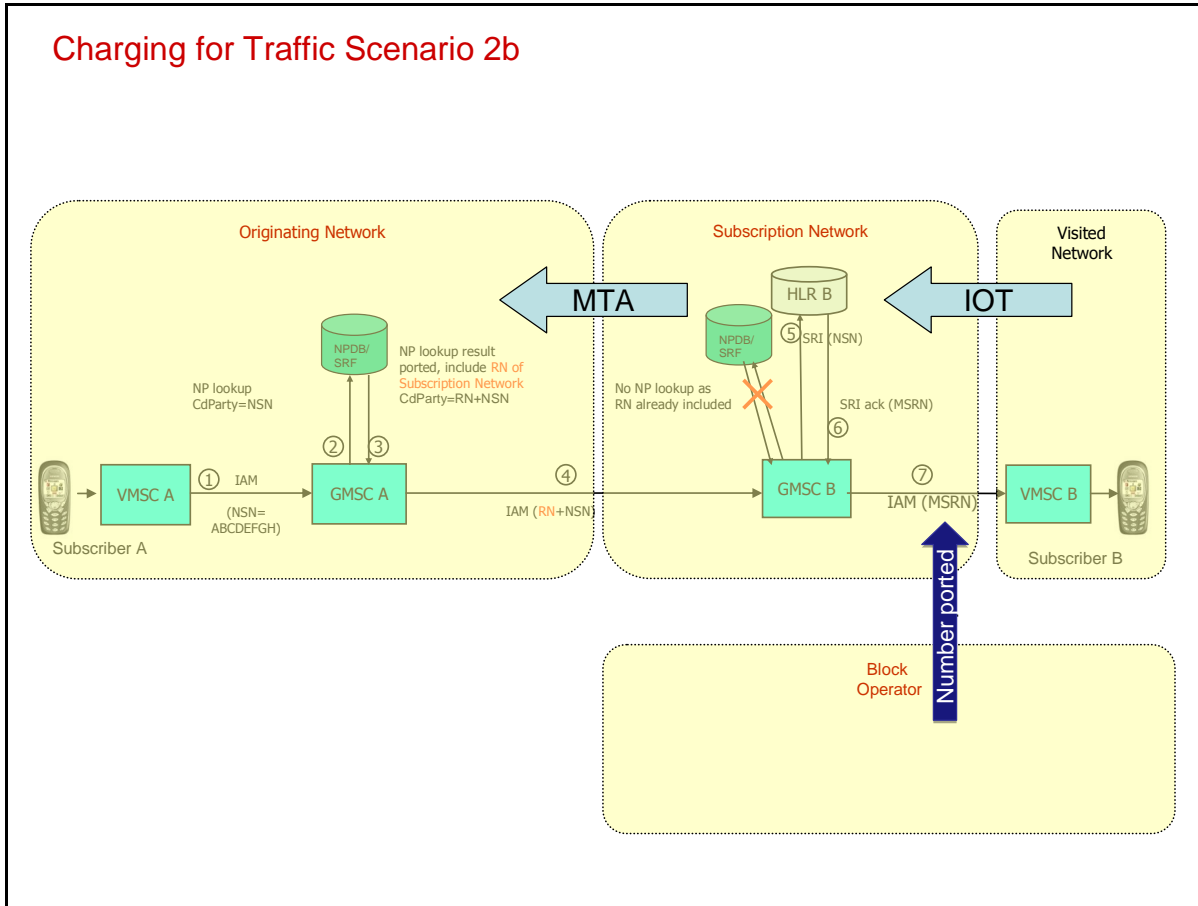

Figure 26. Interconnect settlement for calls to ported number (ACQ) – roaming

Charging for Traffic Scenario 3a

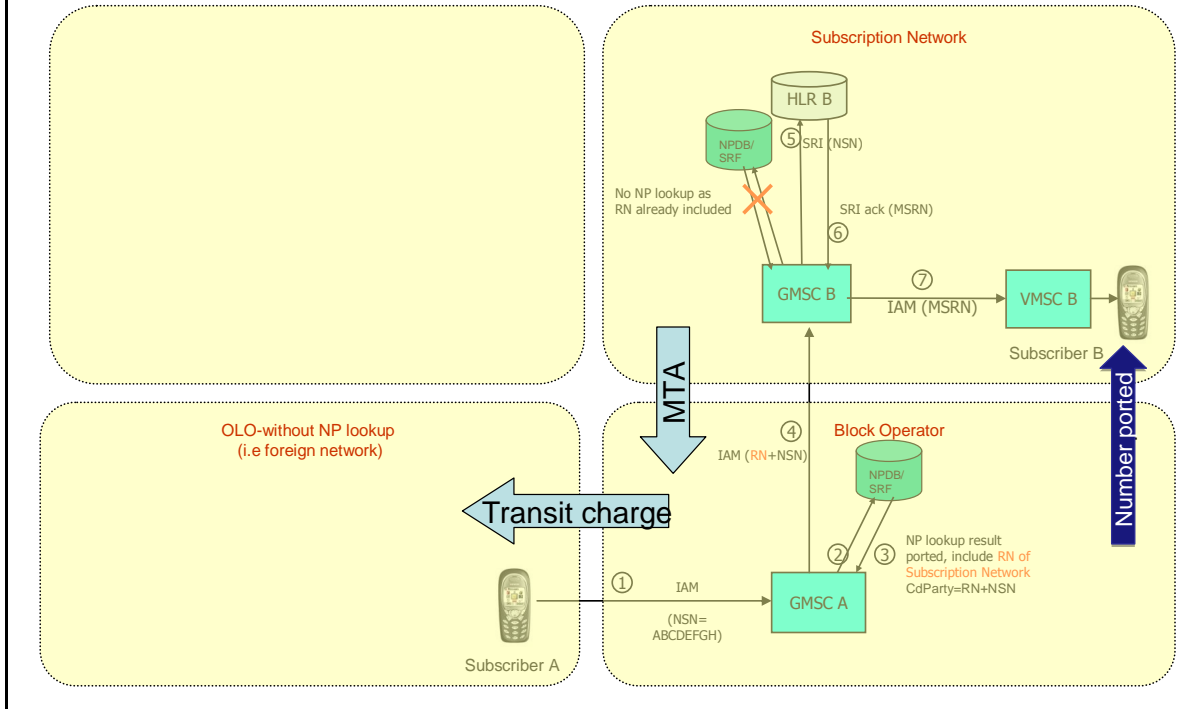

Figure 27. Interconnect settlement for calls to ported number (OR) – non roaming

Charging for Traffic Scenario 3b:

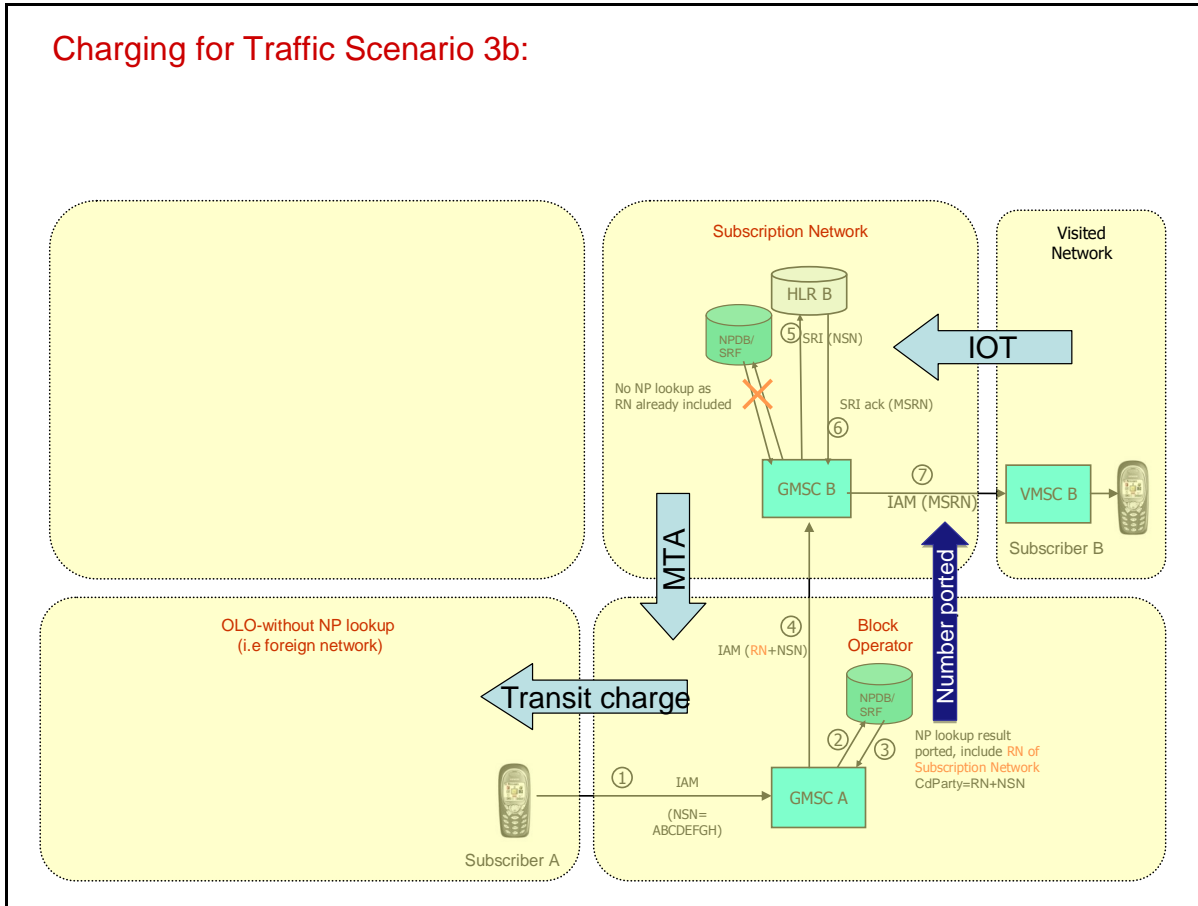

Figure 28. Interconnect settlement for calls to ported number (OR) – roaming

3.4 Charging of calls to ported Fixed Line numbers

3.4.1 General Principles

The charging principles for calls to (ported) Fixed Line numbers are the same as for Mobile numbers. There is a slight difference in terminology: MTA is then called FTA (Fixed Terminating Access fee).

3.4.2 Charging scenario's FNP

Like for MNP, the charges between operators for handling calls are handled via Interconnect agreements and are not subject to the NP specifications. However, for the sake of clarity the scenarios described in chapter 2.3.2 have been depicted in the following figures.

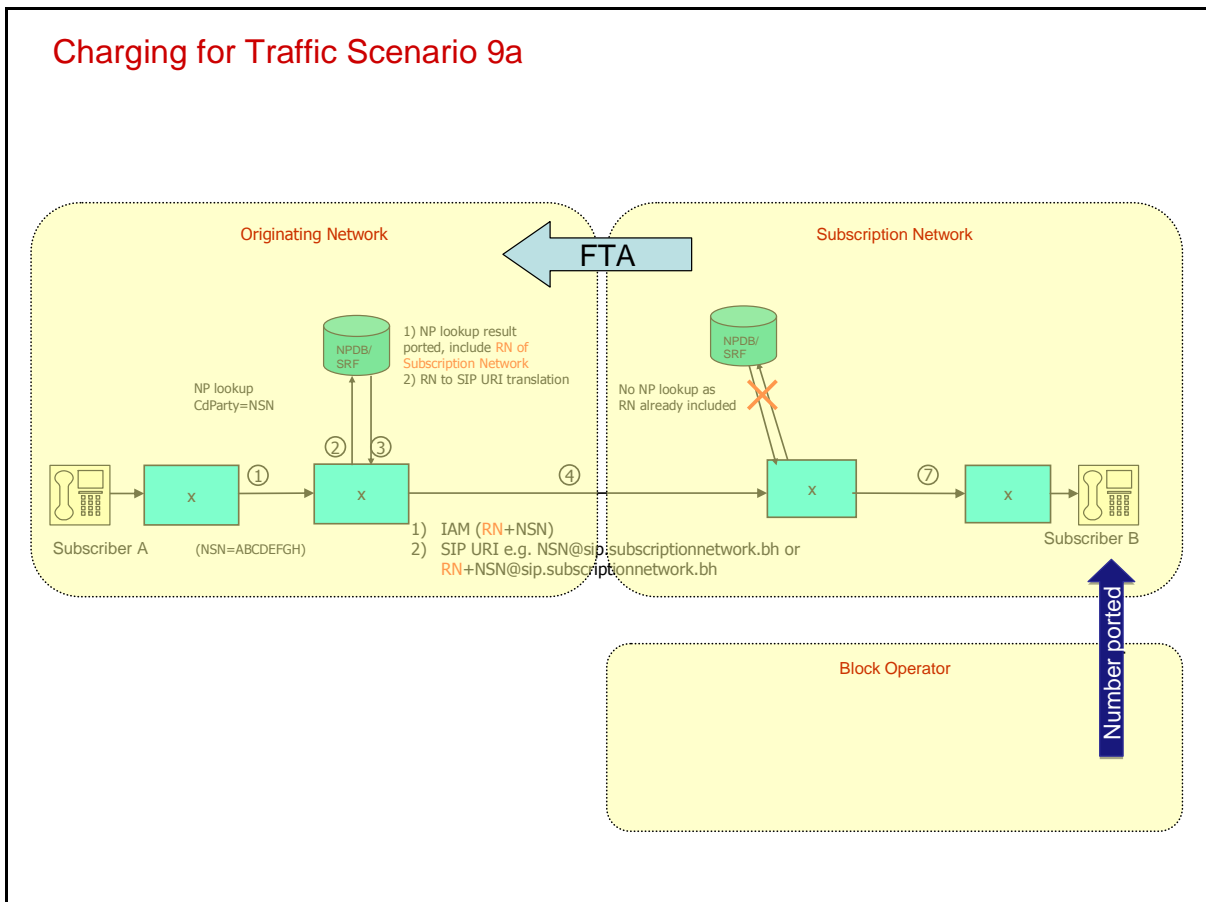

Figure 29. Interconnect settlement for calls to ported Fixed Line subscriber (ACQ)

Charging for Traffic Scenario 9b

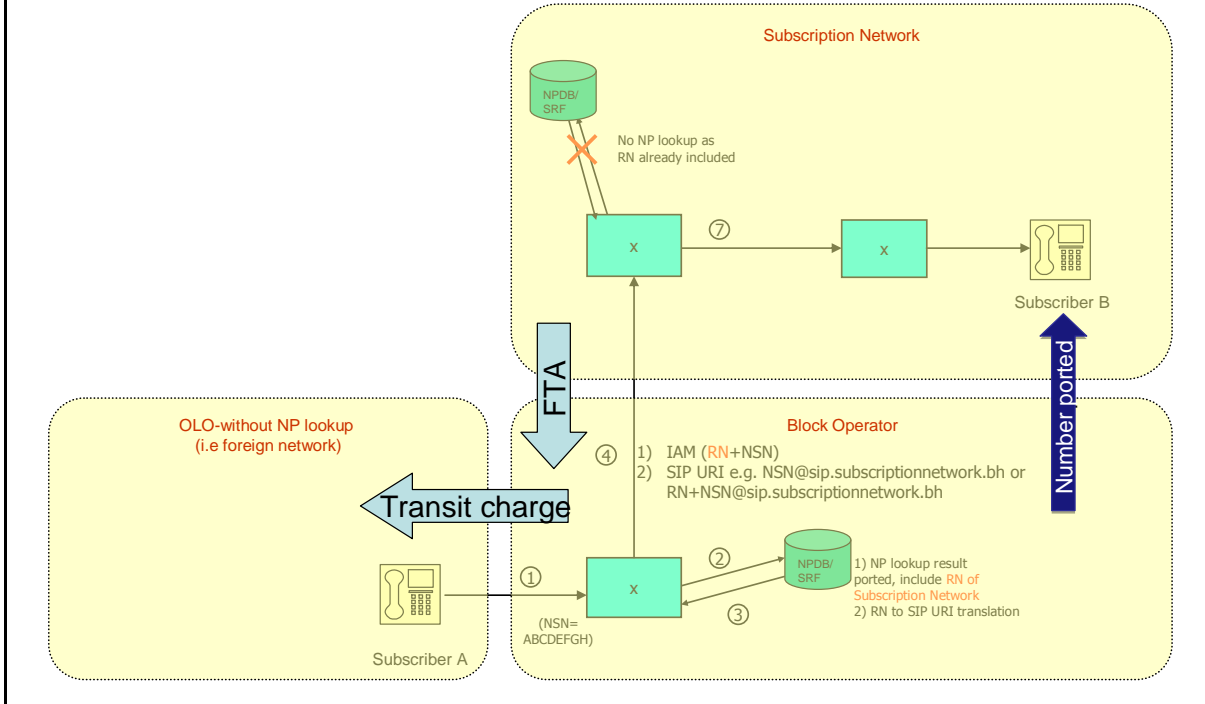

Figure 30. Interconnect settlement for calls to ported Fixed Line subscriber (OR)

Glossary

ACQ	All Call Query
BLOCK Operator	The Licensed Operator who is the original holder of a ported number-as it has been assigned the range
BNPS	Bahrain Number Portability System (central NP database). Central facility for validation of NP messages, Central NP database, administration and reporting, and customer inquiries.
Destination Network	The Licensed Operator which is receiving a calls
DONOR	DONOR Network Operator: the Licensed Operator who is transferring the number to the RECIPIENT
FNP	Fixed Number Portability
FTA	Fixed Terminating Access fee
HLR	Home Location Register
IAM	Initial Address Message (ISUP)
IMSI	International Mobile Subscriber Identity. Number used for identification of a mobile subscriber. It is stored on the SIM card and sent by the phone to the network.
IOT	Inter Operator Tariff
ISUP	ISDN User Part or ISUP is part of the Signaling System #7 which is used to set up telephone calls in Public Switched Telephone Networks.
SRI_SM	Send Routing Info for Short Message (MAP)
MAP	Mobile Application Part (ss7 signaling stack)
MCC MNC	Mobile Country Code & Mobile Network Code, also 5 (in USA 6) digits of imsi
MMSC	Multimedia Messaging Service Centre
MNP	Mobile Number Portability
MSC	Mobile Switching Centre
MSISDN	Mobile Subscriber Integrated Services Digital Network Number

NP	Number Portability: the capability for a subscriber to change licensed operator without changing their number
NSN	National Significant Number
MTA	Mobile Terminating Access fee
OLO	Other Licensed Operator
OR	Onward Routing
Originating Network	The Licensed Operator originating a call
RECIPIENT	RECIPIENT Network Operator: the Licensed Operator to whom the number is being ported
RN	Routing Number
Routing Number	A number (example A01) which is used to route voice calls or signaling (like sms) to the correct Subscription Network. This number is used in the Porting Broadcast messages, which allows participants to update their routing tables accordingly (also known as 'pointers')
Service Provider	A Service Provider is a reseller, using the SIM cards and Mobile Numbers of a Licensed Operator
Serving Network	Term used in the context of a call. This is not necessarily the Subscription Network, as a caller can use another network (international roaming)
SMS-C	Short Message Service Centre
Subscription Network	The network currently serving a subscription. This may be the BLOCK Operator but may also be a ported-to network.
TOR	Terms of Reference
Transit Network	Licensed Operator carrying traffic between the Originating Network and Destination Network
Universal Number	Can be used for both Fixed purposes as Mobile
V-MSC	Visited Mobile Switching Centre