

TELECOMMUNICATIONS REGULATORY AUTHORITY BAHRAIN



هيئة تنظيم الاتصالات
Telecommunications Regulatory Authority

Number Portability Process Specification

Version: 1.0
Status: Final
Date: 31-10-2010

Modification History

Issue	Date	Modification
0.1	27-09-2009	First draft Specification document
0.2	26-10-2009	Second draft Specification, completed chapters, incorporated operator's comments to Specification version 01 and decisions from working groups
0.3	09-11-2009	Review of previous versions included. Results of MNP WG included.
0.31	18-11-2009	Change of text concerning resolution procedure changed
0.4	09-12-2009	Review of Specification text, clarifications, and proof-reading in preparation for public consultation
0.5	14-01-2010	Formatting changes
0.6	21-07-2010	Corrections, feedback from consultation taken into account
0.7	26-08-1020	Final corrections and format changes
0.8	07-09-2010	Update after sessions on 07-09-2010
1.0	18-10-2010	Finalised version

Distribution

Issue	Date	Addressees
0.1	27-09-2009	Mobile Number Portability Working Group (MNP WG), TRA
0.2	26-10-2009	Mobile Number Portability Working Group (MNP WG), TRA
0.3	09-11-2009	Mobile Number Portability Working Group (MNP WG), TRA
0.31	18-11-2009	Mobile Number Portability Working Group (MNP WG), TRA
0.4	09-12-2009	Public Consultation
0.5	29-03-2009	TRA
0.6	21-07-2010	TRA
0.7	26-08-2010	TRA
0.8	07-09-2010	TRA
1.0	18-10-2010	Publication

Review History

Issue	Date	Reviewed By
0.1	22-10-2009	Batelco, STC, ZAIN
0.5	Consultation period	Batelco, STC, ZAIN, Ericsson, GIZA Systems, Systor (Public Consultation)

Referenced Documents

Reference	Description
[1]	Number Portability Regulation issued by the Telecommunications Regulatory Authority; 27-04-2010.
[2]	National Numbering Plan; 10-09-2008; final version;
[3]	Central System Specification; Final v1.0; 31-10-2010;
[4]	Routing and Charging Specification; Final v1.0; 31-10-2010;

Contents

1	Introduction	5
1.1	Number Portability Implementation in the Kingdom of Bahrain.....	5
2	Number Portability (MNP and FNP).....	6
2.1	Definitions	6
3	Number Portability Procedures.....	7
3.1	Number Porting procedures and exchange of messages	7
3.1.1	Phase 1: Preparation.....	7
3.1.2	Phase 2: Execution.....	11
3.1.3	Phase 3: Deactivation	12
3.1.4	Phase 4: NP Query.....	13
3.1.5	Phase 5: Billing Resolution Process	14
3.2	Error Notifications	17
4	NP Messages	19
4.1	NP messages codes	19
4.2	NP message description.....	20
4.3	NP Message fields description	23
4.4	Operator Codes and Routing Numbers.....	29
4.5	NP messages structure	30
4.5.1	Porting Request (NpRequest).....	30
4.5.2	Porting Request Acknowledgement (NpRequestAck)	31
4.5.3	Porting Request Acceptance (NpRequestAccept).....	32
4.5.4	Porting Request Rejection (NpRequestReject).....	33
4.5.5	Porting Cancellation (NpRequestCancel)	35
4.5.6	Porting Execution (NpExecute)	36
4.5.7	Porting Broadcast (NpExecuteBroadcast)	36
4.5.8	Porting Executed (NpExecuteComplete)	37
4.5.9	Deactivation (NpDeactivate)	38
4.5.10	Deactivation Acknowledgement (NpDeactivateAck).....	38
4.5.11	Deactivation Broadcast (NpDeactivateBroadcast)	39
4.5.12	Deactivation Complete (NpDeactivateComplete)	39

4.5.13	NP Query (NpQuery).....	40
4.5.14	NP Query Complete (NpQueryComplete).....	41
4.5.15	Billing Resolution (NpBillingResolution).....	41
4.5.16	Billing Resolution End (NpBillingResolutionEnd).....	42
4.5.17	Billing Resolution Received (NpBillingResolutionReceived).....	43
4.5.18	Billing Resolution Alert (NpBillingResolutionAlert).....	43
4.6	Error Notifications	44
4.6.1	Structure of Message	44
4.6.2	Error Codes	46
5	Porting Conditions	48
5.1	Preparation	48
5.2	Execution	57
5.3	Deactivation.....	60
5.4	Query	64
5.5	Billing Resolution	66
5.6	Number Portability Procedure Flow Diagrams	70
6	Procedure for use of Error Code ERR0099 and Reject Code REJ0099.....	75
7	Rules for use of Error Code ERR0029 “Unexpected or inconsistent data”	76
8	Complex Porting Situations.....	77
9	Number Portability Process for Universal Numbers.....	79
10	Porting Windows/ Timers Definitions.....	80
11	Key Performance Indicators (KPI).....	87
	Glossary	89

1 Introduction

This document is issued pursuant to Article 3 of the Number Portability Regulation (the “Regulation”) issued by the Telecommunications Regulatory Authority of the Kingdom of Bahrain (TRA) on April 27, 2010¹. It contains the detailed specification for the processes associated with both Fixed Number Portability (FNP) and Mobile Number Portability (MNP) as must be implemented within the Kingdom of Bahrain.

1.1 Number Portability Implementation in the Kingdom of Bahrain

Article 6 of the Regulation establishes that Number Portability is a Recipient-led process that is initiated when a Subscriber submits a valid Number Portability Request and any necessary supporting documents to the Recipient Operator. Article 6(c) of the Regulation explicitly prohibits contact between the Donor Operator and the Subscriber in the context of Number Portability. Consequently the Recipient Operator, through the Central System, coordinates all communications concerning Number Portability.

Details on the Central System are referenced in Specification [2], Central System Specification.

Details on routing and charging processes are specified in Specification [3], Routing and Charging Specification.

Article 5(a) of the Regulation obliges all Licensees granted a Telecommunications License that allows the use of Numbers to implement Number Portability. Article 4 mandates the use of a Central System by all such Licensees, who must be connected to the Central System and use it in accordance with the Number Portability Specifications.

Article 11 of the Regulation articulates that the Authority will establish and administer the Central System and that each Licensee obliged to implement Number Portability shall bear its own costs relating to its own copy (Licensee Copy) of the Central System, connectivity between the Licensee Copy and the Central System as well as routing and support systems required in order to comply with the obligations of the Regulation. Figure 1 illustrates the Number Portability network that will be implemented as a consequence of the Regulation.

¹ The Number Portability Regulation is available at “http://www.tra.org.bh/en/pdf/NPRegulation-English_2_.pdf”

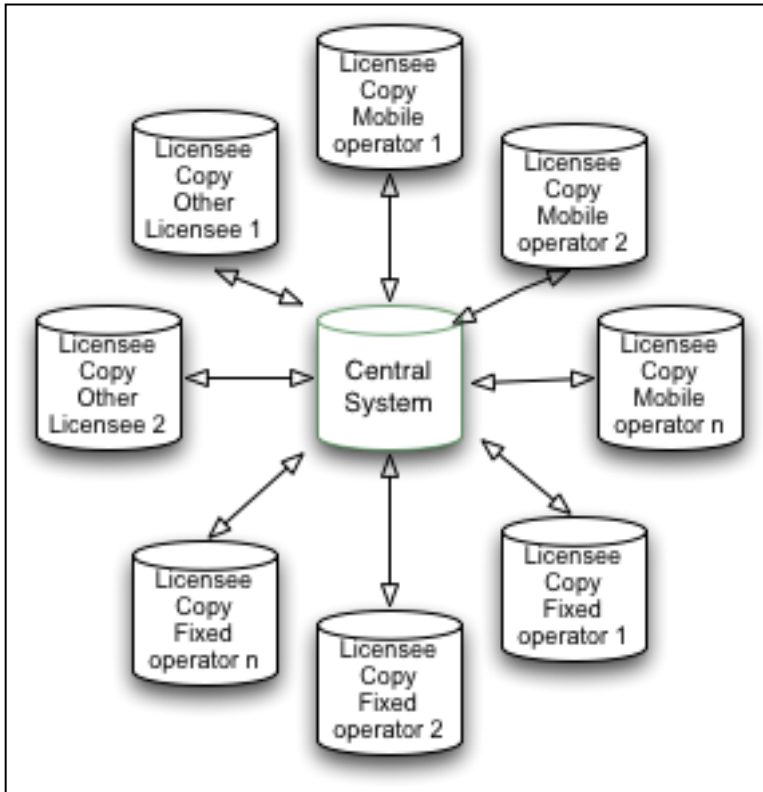

Figure 1 Centralized model for NP implementation

2 Number Portability (MNP and FNP)

2.1 Definitions

Unless otherwise stated herein all capitalized terms will have the same meaning as that ascribed to it in the Regulation, the National Numbering Plan or the Telecommunications Law.

“**Other Operator**” means any party involved in a particular instance of the Number Portability Process other than the Donor Operator or Recipient Operator.

“**Serving Operator**” means the network on which the Subscriber is located.

“**Subscription Network**” means the network to which a Number has been Ported.

3 Number Portability Procedures

3.1 Number Porting procedures and exchange of messages

The generic process of Number Portability has been broken down into five discrete procedural phases that have been developed to apply to Fixed Numbers, Mobile Numbers, Universal Numbers and Special Numbers. These procedural phases include:

- Preparation
- Execution
- Deactivation
- Query
- Billing Resolution

3.1.1 Phase 1: Preparation

Number Portability is initiated when a Subscriber submits a Number Portability Request to the Recipient Operator. Once the Request is accepted as complete by the Recipient Operator, the Number Portability Request is forwarded to the Central System for validation. The Central System acts as a filter and either acknowledges the Number Portability Request, in which case it is forwarded to the Donor Operator or is rejected and returned to the Recipient Operator. There are eight (8) reasons for which the Central System may reject a Number Portability Request which are listed in Section 4.5.4.1.

Once acknowledged and forwarded by the Central System to the Donor Operator the Number Portability Request is subject to further validation by the Donor Operator. Nine (9) reasons for which the Donor Operator may reject the Number Portability Request are listed in Section 4.5.4.1.

An accepted Number Portability Request can only be cancelled by the direct request of the Subscriber. This can occur at any stage of the Porting Process prior to initiation of the execution phase.

If a Recipient Operator wishes to Port several Numbers such as a range of Numbers, or a group of non-consecutive Numbers belonging to one Subscriber (e.g. to one company), then the Recipient Operator should send individual Porting Requests for each of these Numbers. This is applicable also in case of fax or data Numbers (GSM Phase 2 service), or in case of MSN Numbers for ISDN. Please refer to Section 8 Complex Porting Situations of this Specification for further details.

There are four possible scenarios for the preparation phase:

- 1) The Porting Request is rejected by the Central System (figure 2)
- 2) The Porting Request is rejected by the Donor Operator (figure 3)

- 3) The Porting Request is accepted by the Donor Operator (figure 4)
- 4) The Porting Request is cancelled by the Recipient Operator upon request by the Subscriber (figure 5)

It should be noted that the Central System will not change the acceptance or rejection information in the Donor Operator's response to a Porting Request.

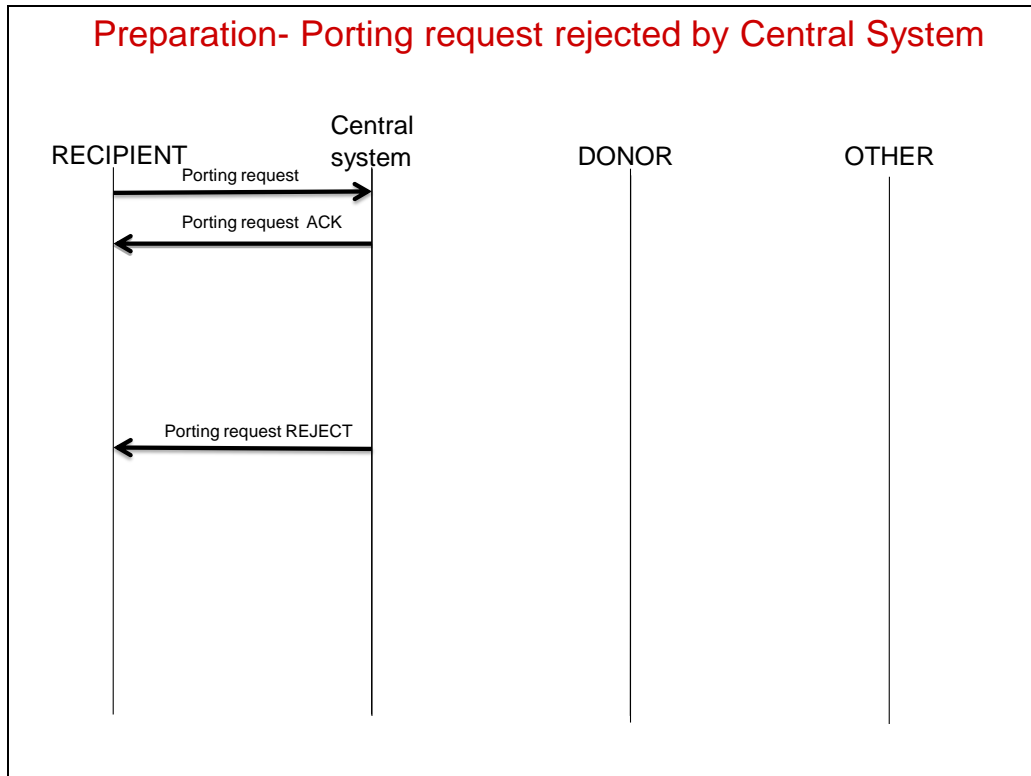

Figure 2 Message Flow Diagram of the preparation phase - Porting Request rejected by the Central System

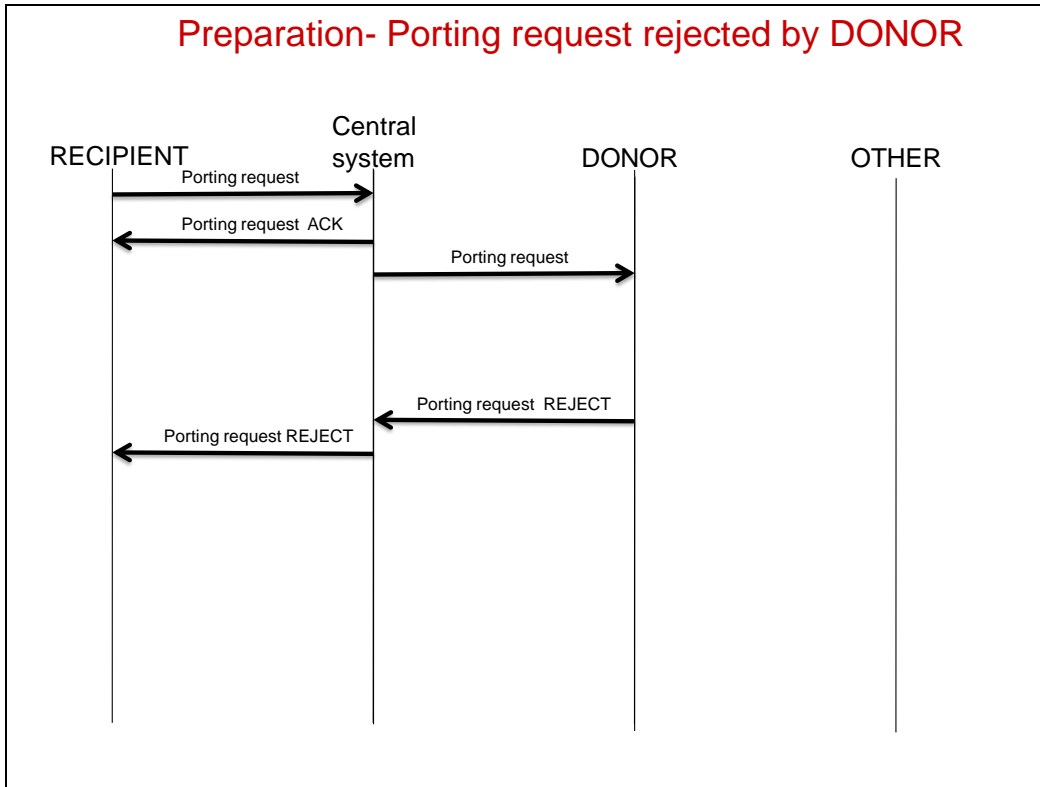

Figure 3 Message Flow Diagram of the preparation phase - Porting Request rejected by the Donor Operator

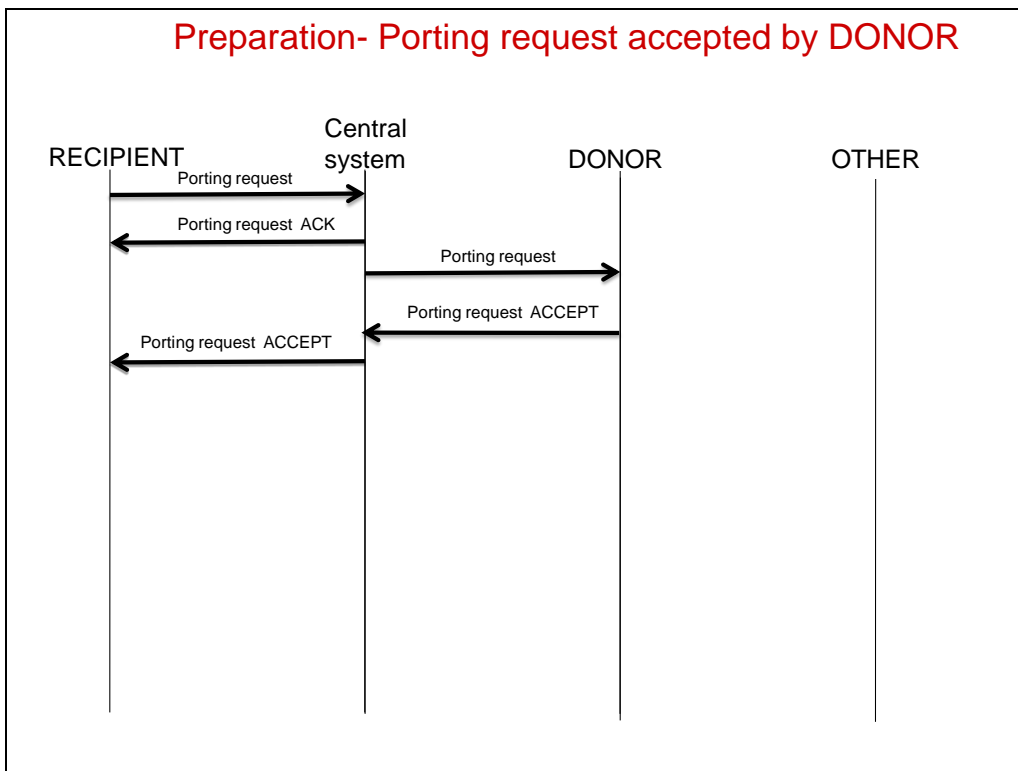

Figure 4 Message Flow Diagram of the preparation phase - Porting Request accepted by the Donor Operator

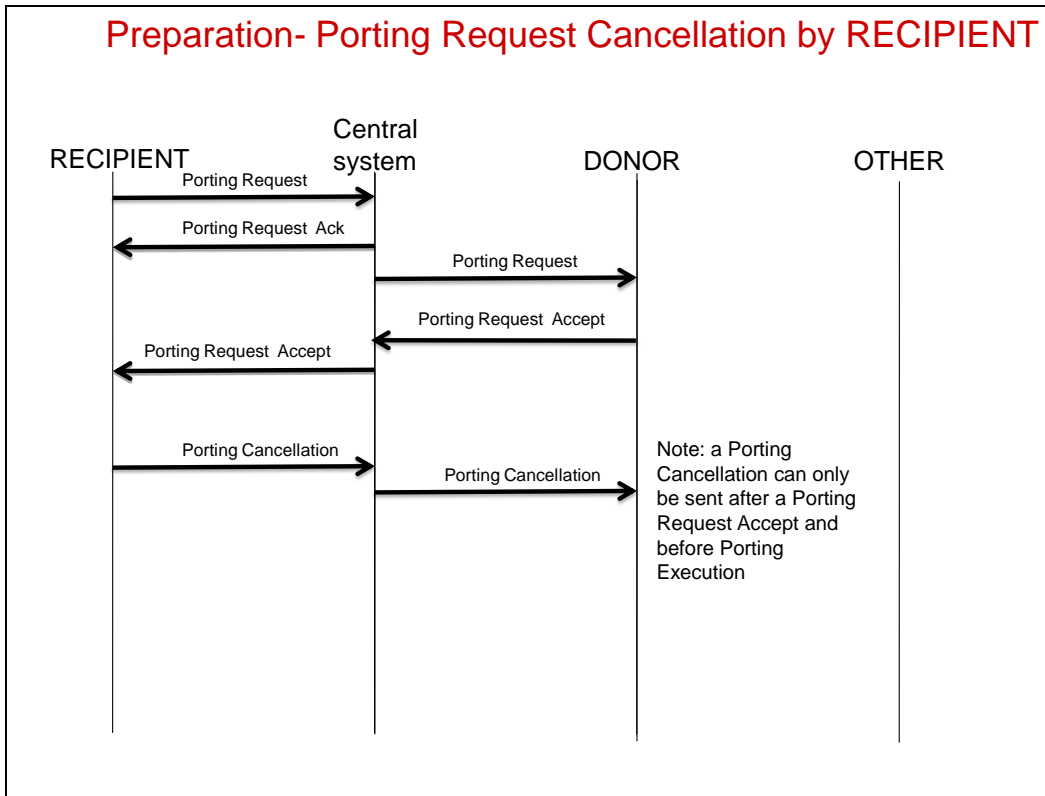

Figure 5. Message Flow Diagram of the preparation phase - Porting Request cancelled by the Recipient Operator

3.1.2 Phase 2: Execution

During the Execution phase the Donor and Recipient Operators will prepare for and execute the Porting of a Number.

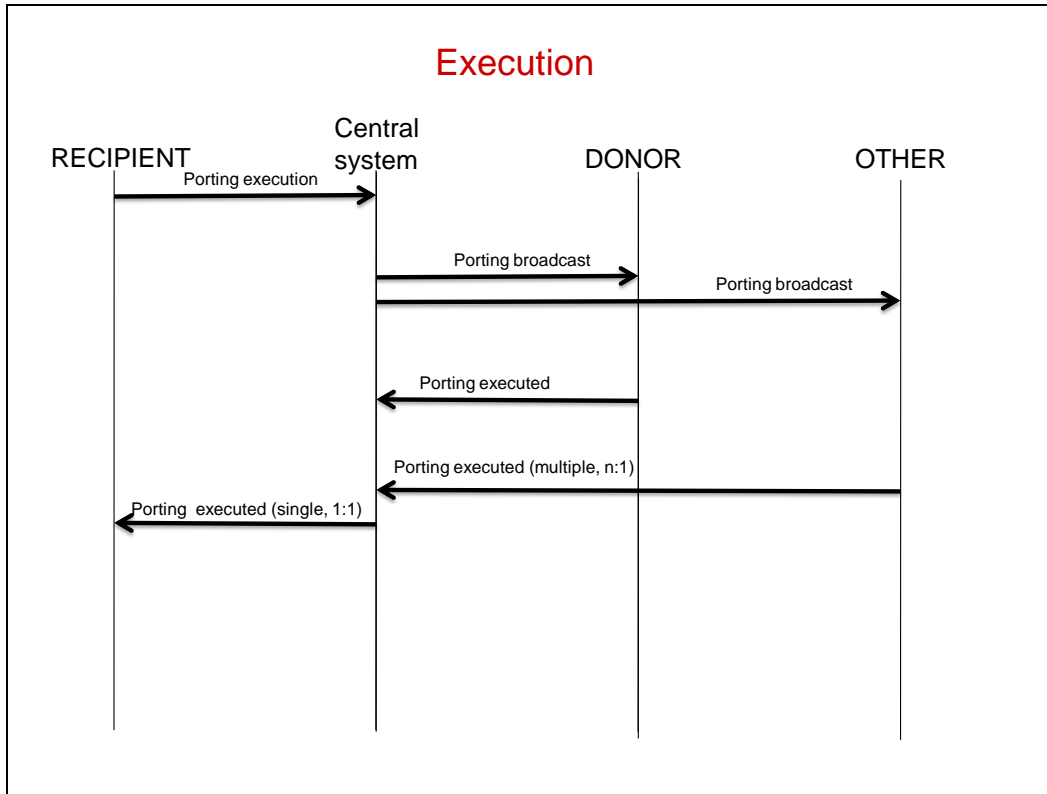

Figure 6 Message Flow diagram of the Execution phase

The Recipient Operator will send a Porting Execution message to the Central System once the Ported Number has been connected to its' network. The Central System will broadcast the execution of the Porting Process to the Donor Operator and all Other Operators.

The Donor Operator, on receiving the Porting Broadcast message, will disconnect the Number from its' network and respond with a Porting Executed message. All Other Operators will have to update their network routing database and systems accordingly.

Upon receipt of a successful response to the Porting Execution message from the Donor Operator, the Central System will send a Porting Executed message to the Recipient Operator (default configuration). In the Central System it could optionally be configured whether:

- the key transit operators should also have responded;
- a set of other operators should also have responded;
- all operators should also have responded.

3.1.3 Phase 3: Deactivation

The Deactivation process concerns the return of a Number to the Block Operator who has been assigned the Number Range to which the previously Ported Number belongs to. The Number will be returned within the allowed Return Period after the Subscription Network has disconnected that Number from its' network. All Other Operators will also be informed about the Deactivation via a broadcast message. This enables Licensees to update their network routing database and systems accordingly.

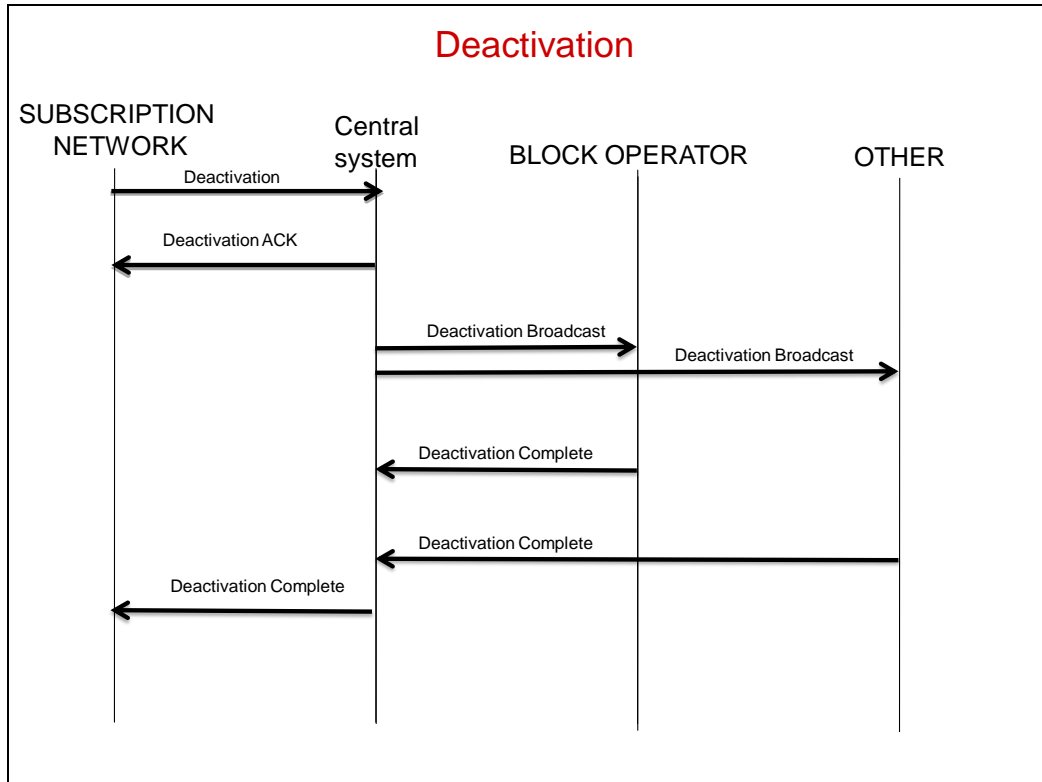

Figure 7 Message Flow Diagram of Deactivation

After updating their respective network routing databases, each Operator, including the Block Operator, will respond to the Deactivation Broadcast message with a Deactivation Complete message.

Upon receipt of a successful response to the Deactivation Broadcast message from the Block Operator, the Central System will send the Deactivation Complete Message to the Subscription Network (default configuration). In the Central System it could optionally be configured whether:

- the key transit operators should also have responded;
- a set of the other operators should also have responded;
- all operators should also have responded.

The Ported Number must be returned to the Block Operator if the Subscriber has been disconnected for any reason other than subsequent Number Porting, and only the Block Operator is entitled to re-use the Number for a new subscription.

3.1.4 Phase 4: NP Query

Operators will be able to request and obtain Number Porting data from the Central System by sending a NPQuery message² to the Central System. The NPQuery message is intended to allow Licensees to request a specified extract of the Ported Number Database for their reference or records. The NPQuery message is not intended to be used for real-time lookup for call routing. The NPQuery message will define which set of data is requested. The Central System will respond to the NPQuery message by sending the response 'NPQueryComplete'. The Central System will also store a file for the requestor that contains the requested data at a designated location. The query process allows for specific criteria:

- Service Type
- Start date/time
- End date/time
- Operator Code
- Number or Number Range

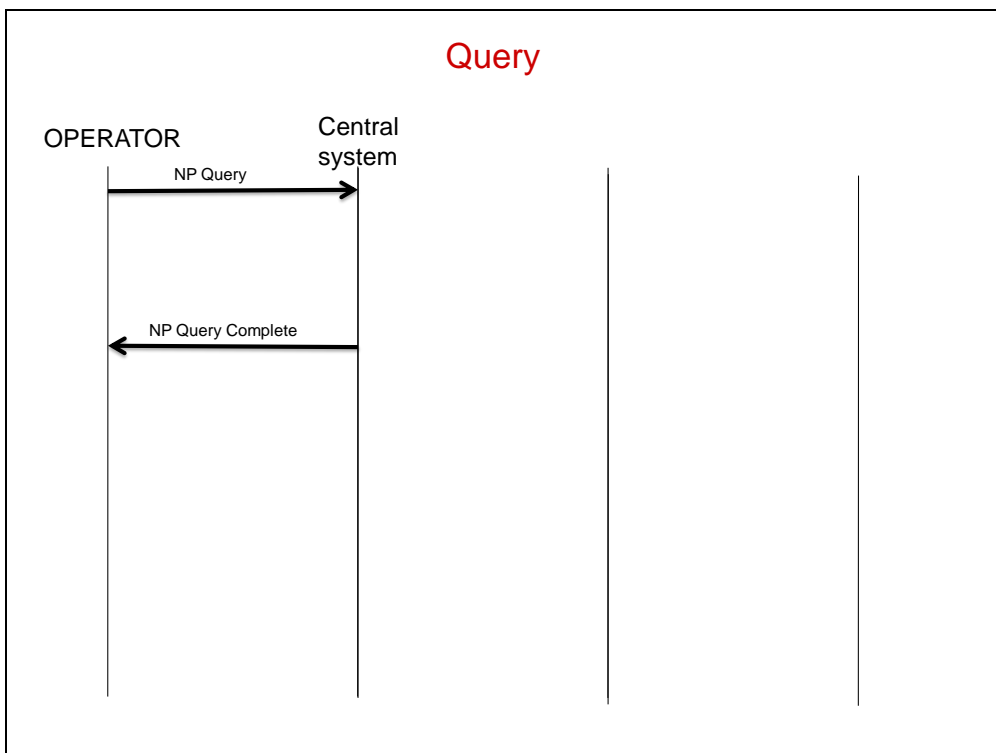

Figure 8 Message Flow diagram of NPQuery message

² This Query message is not intended to be used for real time look-ups for call processing, as described in Specification [3], Routing and Charging.

3.1.5 Phase 5: Billing Resolution Process

After the Porting of a Number has been completed, a phase may be started in which the Subscriber is obliged to settle any outstanding and overdue payments owed to the Donor Operator for services to the Number which has been Ported.

If within a certain period, known as the Billing Notification Period, a Subscriber who has previously Ported their Number still has Bad Debt (as defined in the Regulation) with their Donor Operator, the Donor Operator may initiate the Billing Resolution process in order to assist in the recovery of the outstanding owed amounts. The Donor Operator sends the Billing Resolution message to the Central System, which forwards the message to the Subscription Network. The Subscription Network responds with the Billing Resolution Received message.

During the Billing Resolution process the service to the Subscriber's Ported Number will face incrementally increasing service degradation, as long as the outstanding Bad Debt is not cleared.

There are three levels of service degradation defined in the Billing Resolution process:

Level 1: Barring of international outgoing calls

Level 2: Barring of all outgoing calls

Level 3: Disconnection of the Ported Number and return of the Ported Number to the Block Operator

The minimum time between levels is called the Minimum Billing Resolution Alert time. The maximum time between levels is the Maximum Billing Resolution Alert Time. The Donor Operator may send a Billing Resolution Alert message to instruct the Recipient Operator to proceed to the next level of service degradation. Each sequential Billing Resolution Alert message must be received before the Maximum Billing Resolution Alert Time expires.

The Billing Resolution process ends either when:

- 1) The NPBillingResolutionEnd message has been sent from the Donor Operator (the Subscriber has settled the Bad Debt with the Donor Operator). Upon receipt of this message, all normal services provided by the Subscription Network to this Number will be reactivated, as per the contractual arrangements between the Subscriber and the Subscription Network.
- 2) The Subscriber has not settled the outstanding Bad Debt, and the Subscription Network Operator has received each of the sequential Billing Resolution Alert Messages within the allowed time frame. In this case the Subscription Network will disconnect the Number and discontinue services to that Number. The Number must then be returned to the Block Operator within 30 days and cannot be reused or reissued by the Subscription Network. This outcome of the Billing Resolution process can only be reached if the Donor Operator has sent all Billing Resolution Alert messages within the allotted time period for each message.
- 3) The Donor Operator has not submitted any of the Billing Resolution Alert messages within their allotted time period (Maximum Billing Resolution Alert Time expired for any of the three levels). In this case all normal services provided by the Subscription

Network to this Number will be reactivated, as per the contractual arrangements between the Subscriber and the Subscription Network.

A Donor Operator can submit only one Billing Resolution message for each Porting case (per PORT_ID).

These situations are depicted as follows:

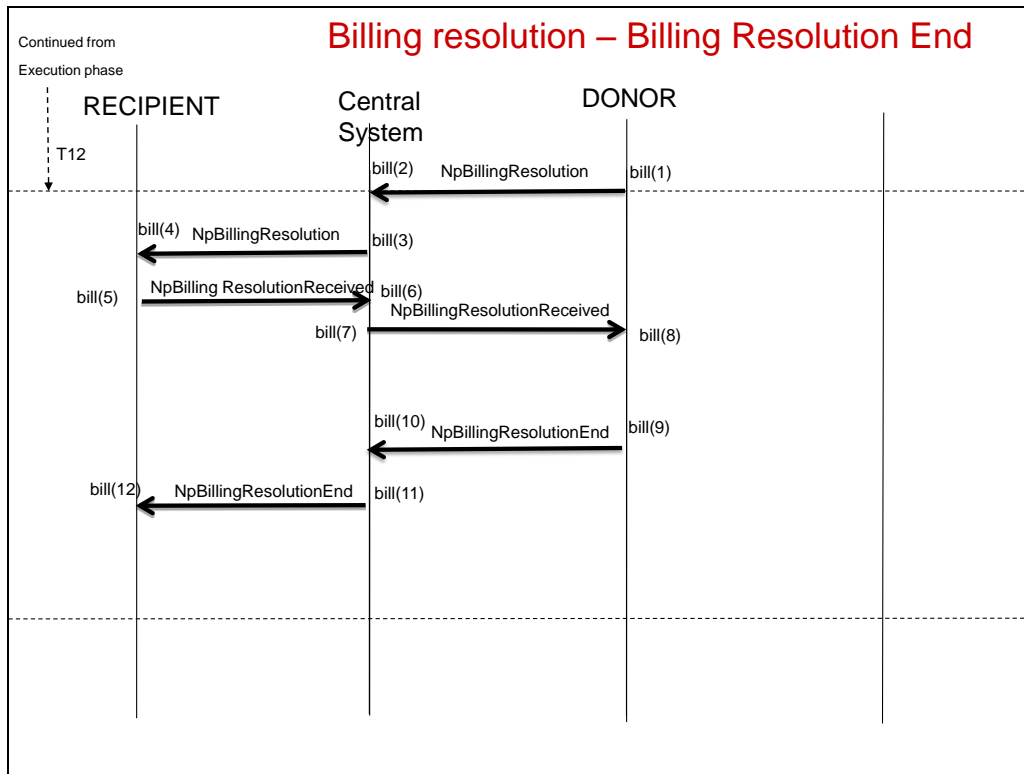

Figure 9 Message Flow Diagram - Billing Resolution End

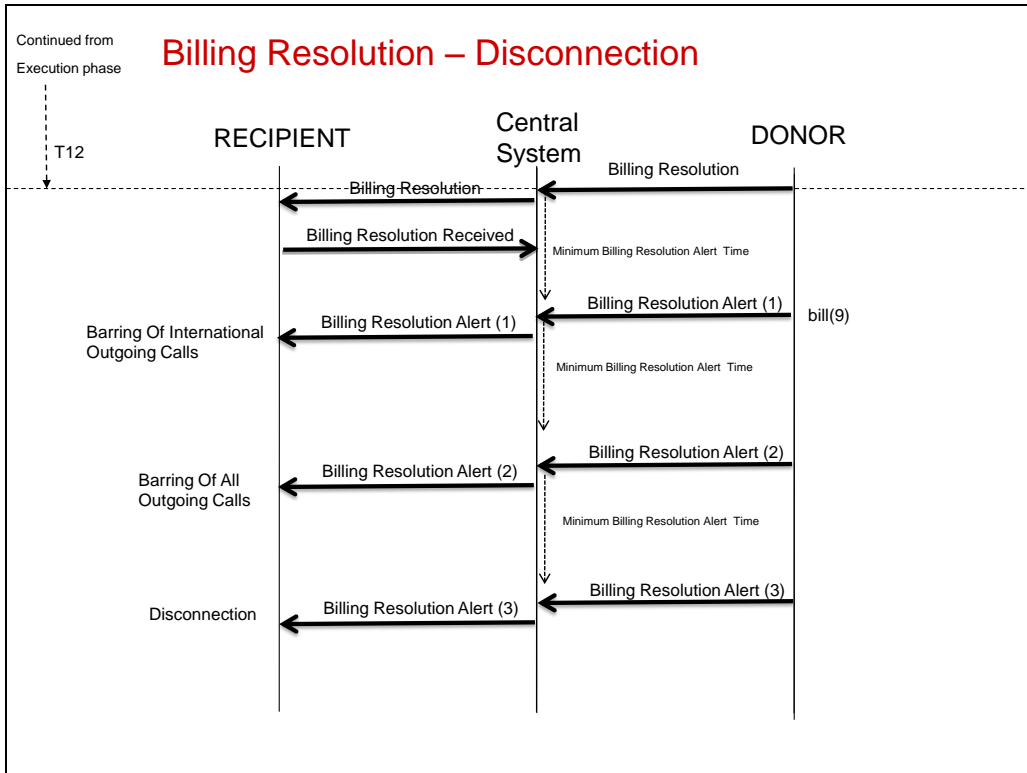

Figure 10 Message Flow Diagram – Billing Resolution Disconnection

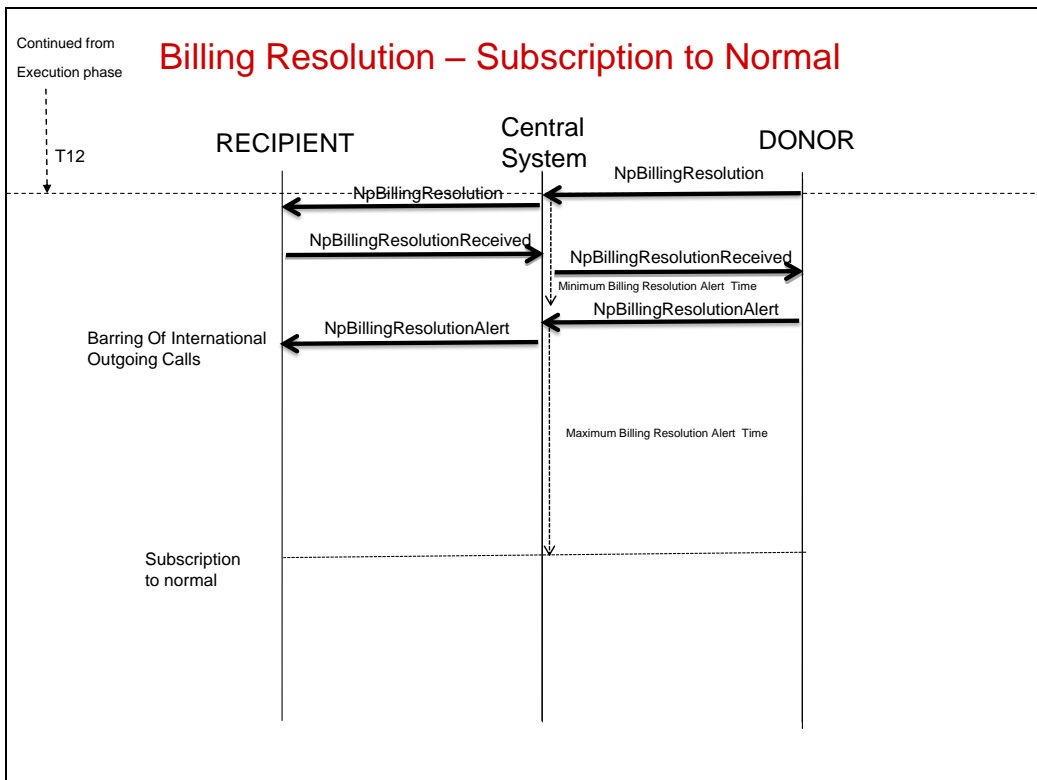

Figure 11 Message Flow Diagram - Billing Resolution Return of Subscription to Normal

At no time will the Recipient Operator become responsible or liable for the outstanding unpaid amounts owed by the Subscriber to the Donor Operator. The Subscriber that decided to Port a Number will remain responsible for any liabilities.

The Donor Operator has the responsibility of issuing the invoices in a timely manner to the Subscriber. The Donor Operator must invoice the Subscriber for any outstanding dues, including roaming charges, penalty fees and outstanding contract amounts.

The Subscriber has the right to dispute the amounts billed to them by the Donor Operator (incorrect invoices, administrative inconsistencies, dues already settled previously, etc) per normal dispute resolution procedures as described in Sections 55 and 56 of the Telecommunications Law of the Kingdom of Bahrain. It is the Subscriber's responsibility to follow up with the Donor Operator to resolve these issues.

At any of the Service Degradation levels, the Donor Operator must send reminders to the Subscriber regarding the payment. These reminders may only be sent by SMS, Email, postal delivery, or by Automatic Call Announcement.

The Central System will raise a flag for each Number that has an ongoing Billing Resolution process. If the flag is raised, the Central System will reject any new Porting Requests for that Number. Specific Reject Codes have been defined for such cases. Upon completion of the Billing Resolution process, regardless of outcome, the flag will be removed.

If a Porting Request for a Number has already been approved prior to the initiation of a Billing Resolution process on the same Number, the Central System will block the execution of the Porting Execution message. Specific Error Codes have been defined for such cases.

3.2 Error Notifications

All participants (Recipient Operator, Subscription Network, the Central System, Donor Operator, Other Operators, Block Operator) can send an Error Notification to any message received in the following cases:

- The NP message format is incorrect, incomplete or cannot be read;
- The content of the message fields are not according to the specified format;
- The NP message is out of sequence.

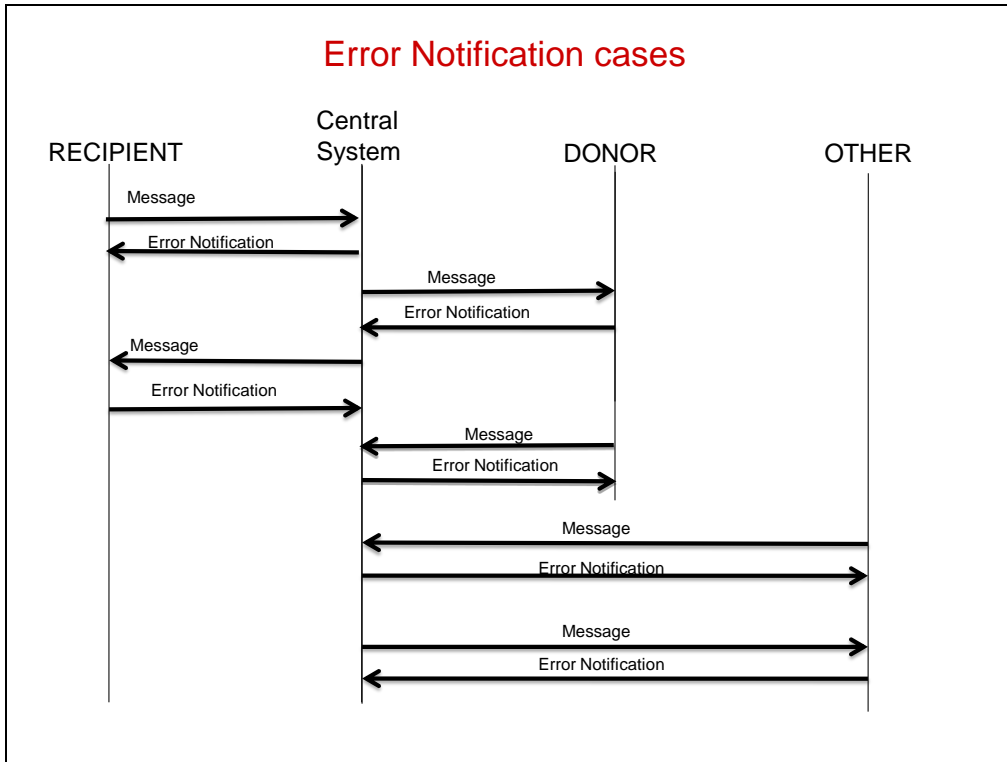

Figure 12 Message Flow Diagram - Error Notification Example

The Error Notification shall contain an Error Code, indicating what part of the NP message was found to be in error. See Section 4.6 for details on Error Messages.

4 NP Messages

4.1 NP messages codes

The following table defines the Message Codes of the Porting messages:

	Phase	Functional name	Message Code
1	Preparation	Porting Request	NpRequest
2		Porting Request Acknowledge	NpRequestAck
3		Porting Request Accept	NpRequestAccept
4		Porting Request Reject	NpRequestReject
5		Porting Cancellation	NpRequestCancel
6	Execution	Porting Execution	NpExecute
7		Porting Broadcast	NpExecuteBroadcast
8		Porting Executed	NpExecuteComplete
9	Deactivation	Deactivation	NpDeactivate
10		Deactivation Acknowledge	NpDeactivateAck
11		Deactivation Broadcast	NpDeactivateBroadcast
12		Deactivation Complete	NpDeactivateComplete
13	Query	NP Query	NpQuery
14		NP Query Complete	NpQueryComplete
15	Billing Resolution	Billing Resolution	NpBillingResolution
16		Billing Resolution End	NpBillingResolutionEnd
17		Billing Resolution Received	NpBillingResolutionReceived
18		Billing Resolution Alert	NpBillingResolutionAlert

4.2 NP message description

The table below explains the purpose of each Porting message and the relation between the messages:

	Message	Purpose	Next message which can be sent by receiver
1	NpRequest	This message is sent from the Recipient Operator to the Donor Operator. The NpRequest starts the Porting Process. The Donor Operator should be able to identify the Subscriber based on provided information. If the NpRequest is rejected, a new NpRequest for the same Number may be sent.	NpRequestAck and either NpRequestAccept OR NpRequestReject
2	NpRequestAck	The Central System validates the Porting Request. If the message and fields are according to the required format (no Error Notification), then the NpRequestAck shall be sent to the Recipient Operator. The Port-ID assigned by the Central System will be part of this message.	none
3	NpRequestAccept	The Donor Operator will send a NpRequestAccept provided that the information in the NpRequest message meets the necessary conditions.	NpRequestCancel OR NpExecute
4	NpRequestReject	The Central System can reject the Porting Request if there are inconsistencies or certain conditions are not met (i.e. Donor Operator is not a valid participant, or another party has already requested Porting for the same Number). The NpRequestReject message will contain the Reject Code, indicating the reason for rejecting the Request. After the Central System has passed the Porting Request to	Optional: NpRequest (new request)

Specification [1]: Number Portability Process Specification

	Message	Purpose	Next message which can be sent by receiver
		the Donor Operator, the Donor Operator will send a NpRequestReject if the provided information does not meet the necessary conditions. The message will contain the Reject Code, indicating the reason for rejection.	
5	NpRequestCancel	The Recipient Operator can cancel the Number Porting, but only after the NpRequest has been accepted and before the NpExecute is sent.	none
6	NpExecute	The Recipient Operator will inform the Central System that the Number to be Ported has been connected on the Recipient Operator network. This will be forwarded by the Central System to all other participants (Donor Operator and Other Operator) as a broadcast (NpExecuteBroadcast)	NpExecuteComplete: one single message from the Central System to the Recipient Operator instead of individual messages from every participant.
7	NpExecuteBroadcast	This message is sent by the Central System to all Operators, allowing them to update their routing tables. In addition, for the Donor Operator, receiving this message is the trigger to disconnect the Porting Number from its' network and systems.	NpExecuteComplete (from Donor Operator and Other Operator)
8	NpExecuteComplete	This message will be sent by all participants who have updated their routing tables after having received the NpExecuteBroadcast. The Donor Operator, after disconnecting the Porting Number from its network, confirms the release of the Number by sending the NpExecuteComplete message. The Central System will send one NpExecuteComplete message to	None

Specification [1]: Number Portability Process Specification

	Message	Purpose	Next message which can be sent by receiver
		the Recipient Operator to confirm that the Porting execution is finalized.	
9	NpDeactivate	<p>This message will be sent to deactivate a Ported Number from the Subscription Network and return that Number to its' Block Operator.</p> <p>The Subscription Network notifies the Central System about the deactivation and the Central System will inform all other participants through the NpDeactivateBroadcast message.</p>	NpDeactivateAck and NpDeactivateComplete
10	NpDeactivateAck	The Central System validates the Deactivation. If the message and fields are according to the required format (no Error Notification), then the NpDeactivateAck message shall be sent to the Recipient Operator. The Port-ID assigned by the Central System will be part of this message.	None
11	NpDeactivateBroadcast	The Central System sends this message to all Operators, after having received a NpDeactivate message. When the Operators receive this broadcast, they will have to update their network routing databases.	NpDeactivateComplete
12	NpDeactivateComplete	When Operators have updated their network routing databases after having received a NpDeactivateBroadcast, they will then send a NpDeactivateComplete message.	none
13	NpQuery	When Licensees or participants wish to receive a full or partial extract of the Ported Numbers Database, they can do so by requesting a file through sending a NpQuery message to the	NpQueryComplete

	Message	Purpose	Next message which can be sent by receiver
		Central System.	
14	NpQueryComplete	The Central System responds with this message, indicating that the requested file is ready. The file shall be transferred to a designated directory on the Central System.	None
15	NpBillingResolution	The Donor Operator sends the NpBillingResolution message to notify the Recipient Operator that a Subscriber has outstanding Bad Debt with the Donor Operator, after the Porting has been executed and within the Billing Notification Period.	NpBillingResolutionReceived
16	NpBillingResolutionEnd	The Donor Operator sends the NpBillingResolutionEnd message following the NpBillingResolution message to notify the Recipient Operator that the Subscriber has no remaining outstanding debt.	None
17	NpBillingResolutionReceived	The Recipient responds to the NpBillingResolution message to notify that the message was received.	Response to NpBillingResolution
18	NpBillingResolutionAlert	The Donor Operator, for the purpose of Billing Resolution, has to send a Billing Resolution Alert message to instruct the Recipient Operator to proceed to the next level of service degradation.	None

4.3 NP Message fields description

Listed below are all possible fields in the NP messages, a description of the content, the format and additional remarks where applicable.

	Field name	Description	Format	Additional Remarks
1	SERVICE_TYPE	Type of telephone service: M (Mobile), F	"M", "F", "S"	' S ' covers Special Services, Premium Rate Services and

Specification [1]: Number Portability Process Specification

	Field name	Description	Format	Additional Remarks
		(Fixed), S (other Services)		Type B Short Codes) A Universal Number is Ported as a Fixed Number ('F') or as a Mobile Number ('M'), depending on how it is classified by the Block Operator.
2	MESSAGE_CODE	The message code corresponding to the Porting message: i.e. NpRequest	See Section 4.1 for NP message codes	
3	NUMBER	The Number to be Ported.	National Significant Number format (NSN), ABCDEFGH	
4	SUBMISSION_ID	Unique ID assigned by the Recipient Operator to a Porting Request.	The SUBMISSION_ID shall be: 4 digit Recipient Operator code-YYYY-8 digit sequence number. Example: ZAIN-2010-00000001	The SUBMISSION_ID may be repeated in several Porting Requests in order to identify that these Porting Requests are linked (e.g. that they belong to the same Subscriber, or are on the same contract)
5	DATE_FROM	Only used for NPQuery to select a specific time span for which a query is required.	YYYYMMDDhhmm	
6	DATE_TO	Only used for NPQuery to select a specific time span for which a	YYYYMMDDhhmm	

Specification [1]: Number Portability Process Specification

	Field name	Description	Format	Additional Remarks
		query is required.		
7	NUMBER_FROM	Only used for NPQuery to select a specific Number Range	Number, National Significant Number format (NSN), ABCDEFGH	
8	NUMBER_TO	Only used for NPQuery to select a specific Number Range	Number, National Significant Number format (NSN), ABCDEFGH	
9	PORT_ID	Unique ID assigned by the Central System to be used in messages referring to this Porting case	For a Number Porting this shall be: 4 digit Recipient Operator code-4 digit Donor Operator code- date of sending Porting Request YYYYMMDD- 5 digit sequential number (restarted each day) in the range of 00000-89999. The combination of Date and Sequence Number is unique. Example: ZAIN-BTCM-20100907-00001	For a deactivation this will be: BLOCK_ID-SUBSCRIPTION_NETWORK_ID-date of sending deactivation YYYYMMDD-5 digit sequence number starting at 90000 Example: ZAIN-VIVA-20101022-90001 See Section 4.4 for the list of Operator Codes
10	DONOR_ID	The ID used by the Central System to identify the Donor Operator.	4 digit operator code, e.g ZAIN See Section 4.4 for operator codes	
11	RECIPIENT_ID	The ID used by the Central System to identify the Recipient Operator.	4 digit operator code, e.g. BTCM See Section 4.4 for operator codes	
12	BLOCK_ID	Used in case of a Deactivation. This ID identifies the Block operator	4 digit operator code, e.g ZAIN See Section 4.4 for	

Specification [1]: Number Portability Process Specification

	Field name	Description	Format	Additional Remarks
		(the original Number holder) of the deactivated Number.	operator codes	
13	OPERATOR_ID	Used only in case of a NpQuery. The OPERATOR_ID is used to select an operator for which the NP Query must be executed.	4 digit operator code, e.g. BTCM See Section 4.4 for operator codes	
14	SUBSCRIPTION_NETWORK_ID	Used in case of a Deactivation. This ID identifies the Subscription Network which has deactivated a Number that was previously Ported in.	4 digit operator code, e.g. BTCM See Section 4.4 for operator codes	
15	NEW_ROUTE	The Routing Number corresponding to the RECIPIENT_ID.	A reference in the range of a01 to a99 and b01 to b99 See Section 4.4 for Routing Numbers	
16	PORTING_DATE_TIME	This is the time and date at which the Porting has taken place according the Central System.	YYYYMMDDhhmm	
17	REJECT_CODE	Used when a Porting Request is rejected. The Reject Code indicates the reason the Request is rejected.	See Section 4.5.4.1 for Reject Codes, e.g. REJ0001	

Specification [1]: Number Portability Process Specification

	Field name	Description	Format	Additional Remarks
18	SIM_CARD_NUMBER	Used only for Mobile Number Portability. The Integrated Circuit Card ID (ICCID, ITU E.118) as written on the SIM card.	Length 18-19 digits Format (ITU E.118) is: 89<cc><mnc><rest >	Formats for the mobile operators are, for example: BTCM : 8997301x..x ZAIN : 8997302x..x VIVA: 8997303x..x
19	COMPANY_FLAG	Used to indicate whether the Subscriber is an individual person or a company.	"Y" if the Subscriber is a company else "N" if the Subscriber is an individual person.	
20	CPR	Central Population Registry number	9 digit number Example: 123456789	If COMPANY_FLAG = Y then the COMMERCIAL_REG_NUMBER is mandatory and CPR and/or PASSPORT_NUMBER should be provided of (any of) the authorized persons representing the company. It is allowed to provide both. If COMPANY_FLAG = N then the COMMERCIAL_REG_NUMBER is left empty. CPR and/or PASSPORT_NUMBER should be submitted. It is allowed to provide both.
21	COMMERCIAL_REG_NUMBER	Commercial Registration Number in case of a company (COMPANY_FLAG is "Y")	5 digit number Example: 12345	
22	PASSPORT_NUMBER	Passport number	12 characters maximum	
23	RESOLUTION_LEVEL	Text field to identify a service degradation level	'LEVEL1', 'LEVEL2', or 'LEVEL3'	

Specification [1]: Number Portability Process Specification

	Field name	Description	Format	Additional Remarks
		in the Billing Resolution Process		
24	COMMENTS	Text field for optional additional information	Free text field, 100 characters maximum	
25	ORIGINATION_ID	The ID of the party that is originating the message.	4 digit operator code, e.g. BTCM See Section 4.4 for operator codes	
26	DESTINATION_ID	The ID of the party that is the message is destined for.	4 digit operator code, e.g. BTCM See Section 4.4 for operator codes	

4.4 Operator Codes and Routing Numbers

The below table defines the operator codes used in the fields DONOR_ID, RECIPIENT_ID, ORIGINATION_ID, DESTINATION_ID, BLOCK_ID and SUBSCRIPTION_NETWORK_ID as well as the associated Routing number as used in the field NEW_ROUTE.

	Company Name	Operator Code	Routing number	Remark
1	Bahrain Telecommunications Company (BATELCO) B.S.C	BTCM	a01	Mobile
2	Zain Bahrain B.S.C. Closed	ZANM	a02	Mobile
3	VIVA Bahrain B.S.C. Closed	VIVA	a03	Mobile
4	Menatelecom W.L.L.	MNAM	a04	Mobile
4	2Connect WLL	2CON	b01	Fixed
5	Atyaf Telecommunications and Infrastructure Bahrain W.L.L.	ATIB	b02	Fixed
6	Bahrain Broadband Co. W.L.L	BABC	b03	Fixed
7	Bahrain Telecommunications Company (BATELCO) B.S.C	BTCF	b04	Fixed
8	Elephant Talk Bahrain W.L.L	ELTA	b05	Fixed
9	Etisacom Bahrain Company W.L.L	ETBC	b06	Fixed
10	Golden Star Telecommunications W.L.L.	GOLD	b07	Fixed
11	Kulacom Communication S.P.C	KULA	b08	Fixed
12	Lightspeed Communications W.L.L	LSCO	b09	Fixed
13	Menatelecom W.L.L	MNAF	b10	Fixed
14	Nuetel Communications S.P.C	NUET	b11	Fixed
15	Rapid Telecommunications W.L.L	RAPD	b12	Fixed
16	Rawabi Telecommunications and Software Co. LTD	RWAB	b13	Fixed
17	Kalam Telecom Bahrain B.S.C Closed	KLAM	b14	Fixed
18	Life Communication B.S.C Closed	LIFE	b15	Fixed
19	Zain Bahrain B.S.C. Closed	ZANF	b16	Fixed
20	Central System	CSYS	N/A	

	Company Name	Operator Code	Routing number	Remark
21	N/A	ALLO	N/A	All Operators in case of broadcast messages

4.5 NP messages structure

4.5.1 Porting Request (NpRequest)

FIELD	Optional/ Mandatory/ Empty/ Conditional	Remark
SERVICE_TYPE	Mandatory	Example "M"
MESSAGE_CODE	Mandatory	"NpRequest"
NUMBER	Mandatory	Example: 31234567
PORT_ID	EMPTY	To be assigned by the Central System
SUBMISSION_ID	Mandatory	Example: BTCM-2010-12345678
DONOR_ID	Mandatory	Example: VIVA
RECIPIENT_ID	Mandatory	Example: BTCM
SIM_CARD_NUMBER	Conditional: Mandatory for Mobile Number Portability Empty for all other forms of Number Portability	Example: 8997301012345678901
COMPANY_FLAG	Mandatory	Example: Y
CPR	Conditional: Mandatory if Passport Number is not provided. Optional otherwise.	Example: 123456789
COMMERCIAL_REG_NUMBER	Conditional Mandatory if COMPANY_FLAG =Y	Example: 12345

Specification [1]: Number Portability Process Specification

FIELD	Optional/ Mandatory/ Empty/ Conditional	Remark
	Empty if COMPANY_FLAG =N	
PASSPORT_NUMBER	Conditional: Mandatory if CPR is not provided. Optional otherwise.	Example: NRDR42CJ9
COMMENTS	Optional	
ORIGINATION_ID	Mandatory	Example: BTCM (equal to RECIPIENT_ID)
DESTINATION_ID	Mandatory	CSYS (equal to the Central System)

4.5.2 Porting Request Acknowledgement (NpRequestAck)

FIELD	Optional/ Mandatory/ Empty/ Conditional	Remark
SERVICE_TYPE	Mandatory	"M"
MESSAGE_CODE	Mandatory	"NpRequestAck"
NUMBER	Mandatory	Example: 31234567
PORT_ID	Mandatory	Provided by the Central System and used throughout the whole Porting Process Example: BTCM-VIVA-20101012-00001
SUBMISSION_ID	Mandatory	Example: BTCM-2010-12345678
DONOR_ID	Mandatory	Example: VIVA
RECIPIENT_ID	Mandatory	Example: BTCM
ORIGINATION_ID	Mandatory	CSYS (equal to the Central System)

FIELD	Optional/ Mandatory/ Empty/ Conditional	Remark
DESTINATION_ID	Mandatory	Example: BTCM (equal to RECIPIENT_ID)

4.5.3 Porting Request Acceptance (NpRequestAccept)

The Central System is transparent for the NpRequestAccept message. No information shall be added by the Central System, except for changing the ORIGINATION_ID and DESTINATION_ID.

FIELD	Optional/ Mandatory/ Empty/ Conditional	Remark
SERVICE_TYPE	Mandatory	"M"
MESSAGE_CODE	Mandatory	"NpRequestAccept"
NUMBER	Mandatory	Example: 31234567
PORT_ID	Mandatory	Provided by the Central System upon receipt of NpRequest and used by all participants throughout the whole Porting Process. Example: BTCM-VIVA-20101012-00001
SUBMISSION_ID	Mandatory	Example: BTCM-2010-12345678
DONOR_ID	Mandatory	Example: VIVA
RECIPIENT_ID	Mandatory	Example: BTCM
ORIGINATION_ID	Mandatory	Either DONOR_ID or Central System
DESTINATION_ID	Mandatory	Either Central System or RECIPIENT_ID

4.5.4 Porting Request Rejection (NpRequestReject)

FIELD	Optional/ Mandatory/ Empty/ Conditional	Remark
SERVICE_TYPE	Mandatory	"M"
MESSAGE_CODE	Mandatory	"NpRequestReject"
NUMBER	Mandatory	Example: 31234567
PORT_ID	Mandatory	Provided by the Central System and used throughout the Porting Process Example: BTCM-VIVA-20101012-00001
SUBMISSION_ID	Mandatory	Example: BTCM-2010-12345678
DONOR_ID	Mandatory	Example: VIVA
RECIPIENT_ID	Mandatory	Example: BTCM
REJECT_CODE	Mandatory	The Central System and the Donor operator will validate the Porting Request against the predefined list of Reject Codes. Example: REJ0001
COMMENTS	Optional	
ORIGINATION_ID	Mandatory	CSYS or DONOR_ID
DESTINATION_ID	Mandatory	RECIPIENT_ID or CSYS

4.5.4.1 Reject codes for NpRequestReject

Reject Codes used by the Central System or Donor Operator:

Code	Text	Central System	Donor Operator
REJ0001	A Porting Process is already in progress for this Number (Request rejected by Central System)	X	
REJ0002	RECIPIENT_ID is not valid (Request rejected by Central System)	X	
REJ0003	DONOR_ID is not valid (Request rejected by Central System)	X	

Specification [1]: Number Portability Process Specification

Code	Text	Central System	Donor Operator
REJ0004	NUMBER and SERVICE_TYPE do not match (Request rejected by Central System)	X	
REJ0005	Wrong Donor Operator: Donor Operator is not serving the Number in the Porting Request (Request rejected by Central System)	X	
REJ0006	The Number requested to be Ported is subject to a Billing Resolution Process (Request rejected by Central System)	X	
REJ0007	Company Flag has unexpected value (Request rejected by Donor Operator)		X
REJ0008	Number is not active or in service (Request rejected by Donor Operator)		X
REJ0009	Subscriber has Bad Debt (Request rejected by Donor Operator)		X
REJ0010	SIM_CARD_NUMBER does not match the SIM chip assigned to the Number (Request rejected by Donor Operator)		X
REJ0011	CPR required for validation (Donor Subscription details include a CPR number) (Request rejected by Donor Operator)		X
REJ0012	CPR and PASSPORT_NUMBER are missing (Request rejected by Central System)	X	
REJ0013	CPR number does not match the requested Porting Number's Subscriber details (Request rejected by Donor Operator)		X
REJ0014	PASSPORT_NUMBER does not match the requested Porting Number's Subscriber details (Request rejected by Donor Operator)		X
REJ0015	PASSPORT_NUMBER required for validation (Donor Subscription details include a Passport Number) (Request rejected by Donor Operator)		X
REJ0016	COMMERCIAL_REG_NUMBER required (Request rejected by Central System)	X	
REJ0017	COMMERCIAL_REG_NUMBER does not match the requested Porting Number's Subscriber details (Request rejected by Donor Operator)		X
REJ0098	Rejection by Central System was expected (Request rejected by Donor Operator) Reason (Rejection code expected from Central System) should be described in COMMENTS field		X
REJ0099	Other (Request rejected by Donor Operator)		X

Code	Text	Central System	Donor Operator
	Reason should be described in COMMENTS field. See Section 6: Procedure for the Use of REJ0099		

The Rejection Code REJ0098 is provided by the Donor Operator, in case that the Donor Operator identifies a situation that already should have been a reason to reject a Porting Request by the Central System. Such situations may exist if the Central System has incorrect or incomplete information. In such case the Donor Operator in the NPRequestReject message should fill in 'REJ0098' in the REJECT CODE field and the expected Reject Code in the COMMENTS field.

E.g. If the Porting Request has an unexpected SERVICE_TYPE, the Donor Operator should fill in 'REJ0004' in the COMMENTS field. This is to indicate the Donor Operator would have expected the Central System to reject the Porting Request with Reject code REJ0004.

4.5.5 Porting Cancellation (NpRequestCancel)

The Central System is transparent for this message to the Donor Operator. No information shall be added by the Central System, except for changing the ORIGINATION_ID and DESTINATION_ID.

FIELD	Optional/ Mandatory/ Empty/ Conditional	Remark
SERVICE_TYPE	Mandatory	"M"
MESSAGE_CODE	Mandatory	"NpRequestCancel"
NUMBER	Mandatory	Example: 31234567
PORT_ID	Mandatory	Example: BTCM-VIVA-20101012-00001
SUBMISSION_ID	Mandatory	Example: BTCM-2010-12345678
DONOR_ID	Mandatory	Example: VIVA
RECIPIENT_ID	Mandatory	Example: BTCM
ORIGINATION_ID	Mandatory	
DESTINATION_ID	Mandatory	

4.5.6 Porting Execution (NpExecute)

FIELD	Optional/ Mandatory/ Empty/ Conditional	Remark
SERVICE_TYPE	Mandatory	"M"
MESSAGE_CODE	Mandatory	"NpExecute"
NUMBER	Mandatory	Example: 31234567
PORT_ID	Mandatory	Example: BTCM-VIVA-20101012-00001
DONOR_ID	Mandatory	Example: VIVA
RECIPIENT_ID	Mandatory	Example: BTCM
ORIGINATION_ID	Mandatory	Example: BTCM
DESTINATION_ID	Mandatory	CSYS

4.5.7 Porting Broadcast (NpExecuteBroadcast)

FIELD	Optional/ Mandatory/ Empty/ Conditional	Remark
SERVICE_TYPE	Mandatory	"M"
MESSAGE_CODE	Mandatory	"NpExecuteBroadcast"
NUMBER	Mandatory	Example: 31234567
PORT_ID	Mandatory	Example: BTCM-VIVA-20101012-00001
DONOR_ID	Mandatory	Example: VIVA
RECIPIENT_ID	Mandatory	Example: BTCM
NEW_ROUTE	Mandatory	example: a03
PORTING_DATE_TIME	Mandatory	Example: 201010141200
ORIGINATION_ID	Mandatory	CSYS
DESTINATION_ID	Mandatory	ALLO

4.5.8 Porting Executed (NpExecuteComplete)

FIELD	Optional/ Mandatory/ Empty/ Conditional	Remark
SERVICE_TYPE	Mandatory	"M"
MESSAGE_CODE	Mandatory	"NpExecuteComplete"
NUMBER	Mandatory	Example: 31234567
PORT_ID	Mandatory	Example: BTCM-VIVA-20101212-00001
DONOR_ID	Mandatory	Example: VIVA
RECIPIENT_ID	Mandatory	Example: BTCM
PORTING_DATE_TIME	Mandatory	Example: 201010141200
ORINATION_ID	Mandatory	DONOR_ID or other Operator ID
DESTINATION_ID	Mandatory	CSYS

4.5.9 Deactivation (NpDeactivate)

FIELD	Optional/ Mandatory/ Empty/ Conditional	Remark
SERVICE_TYPE	Mandatory	"M"
MESSAGE_CODE	Mandatory	"NpDeactivate"
NUMBER	Mandatory	Example: 31234567
SUBSCRIPTION_NET WORK_ID	Mandatory	
BLOCK_ID	Mandatory	
ORIGINATION_ID	Mandatory	BLOCK_ID
DESTINATION_ID	Mandatory	CSYS

4.5.10 Deactivation Acknowledgement (NpDeactivateAck)

FIELD	Optional/ Mandatory/ Empty/ Conditional	Remark
SERVICE_TYPE	Mandatory	"M"
MESSAGE_CODE	Mandatory	"NpDeactivateAck"
NUMBER	Mandatory	Example: 31234567
PORT_ID	Mandatory	Example: ZAIN-VIVA-20101022-90001
SUBSCRIPTION_NET WORK_ID	Mandatory	Example: VIVA
BLOCK_ID	Mandatory	Example: ZAIN
ORIGINATION_ID	Mandatory	CSYS
DESTINATION_ID	Mandatory	Example: ZAIN (Equal to BLOCK_ID)

4.5.11 Deactivation Broadcast (NpDeactivateBroadcast)

FIELD	Optional/ Mandatory/ Empty/ Conditional	Remark
SERVICE_TYPE	Mandatory	"M"
MESSAGE_CODE	Mandatory	"NpDeactivateBroadcast"
NUMBER	Mandatory	Example: 31234567
PORT_ID	Mandatory	Example: ZAIN-VIVA-20101022-90001
SUBSCRIPTION_NETWORK_ID	Mandatory	Example: VIVA
BLOCK_ID	Mandatory	Example: ZAIN
ORIGINATION_ID	Mandatory	CSYS
DESTINATION_ID	Mandatory	ALLO

4.5.12 Deactivation Complete (NpDeactivateComplete)

FIELD	Optional/ Mandatory/ Empty/ Conditional	Remark
SERVICE_TYPE	Mandatory	"M"
MESSAGE_CODE	Mandatory	"NpDeactivateComplete"
NUMBER	Mandatory	Example: 31234567
PORT_ID	Mandatory	Example: ZAIN-VIVA-20101022-90001
SUBSCRIPTION_NETWORK_ID	Mandatory	Example: VIVA
BLOCK_ID	Mandatory	Example: ZAIN
ORIGINATION_ID	Mandatory	DONOR_ID or other OPERATOR_ID
DESTINATION_ID	Mandatory	CSYS

4.5.13 NP Query (NpQuery)

FIELD	Optional/ Mandatory/ Empty/ Conditional	Remark
MESSAGE_CODE	Mandatory	"NpQuery"
DATE_FROM	Optional	Example: 20100101hhmm If left empty then the Central System assumes the whole Ported Number Database or, if provided, an extract of the Database up to the date specified in DATE_TO.
DATE_TO	Optional	Example: 20100922hhmm If DATE_TO is left empty then the Central System assumes the whole Ported Number Database or, if provided, an extract of the Database up to the date specified in DATE_FROM.
NUMBER_FROM	Optional	Example: 30000000 If NUMBER_FROM is left empty then the Central System assumes all Numbers or, if provided, all Numbers up to the Number specified in the NUMBER_TO field.
NUMBER_TO	Optional	Example: 31234567 If NUMBER_TO field is left empty then the Central System assumes all Numbers or, if provided, all Numbers starting from the Number specified in the NUMBER_FROM field.
OPERATOR_ID	Optional	Example: BTCM If OPERATOR_ID is left empty then the Central System assumes all operators.
COMMENTS	Optional	

FIELD	Optional/ Mandatory/ Empty/ Conditional	Remark
ORINATION_ID	Mandatory	The OPERATOR_ID of the sender of the NP query e.g. BTCM
DESTINATION_ID	Mandatory	CSYS

4.5.14 NP Query Complete (NpQueryComplete)

FIELD	Optional/ Mandatory/ Empty/ Conditional	Remark
MESSAGE_CODE	Mandatory	"NpQueryComplete"
COMMENTS	Optional	Copy of comments of NP Query
ORINATION_ID	Mandatory	CSYS
DESTINATION_ID	Mandatory	Initial Requester of the NP Query e.g. BTCM

4.5.15 Billing Resolution (NpBillingResolution)

The Central System is not transparent for this message. The Central System may change the SUBSCRIPTION_NETWORK_ID in cases where the Number has been onward Ported. The Central System will change the ORINATION_ID and DESTINATION_ID.

FIELD	Optional/ Mandatory/ Empty/ Conditional	Remark
SERVICE_TYPE	Mandatory	"M"
MESSAGE_CODE	Mandatory	"NpBillingResolution"
NUMBER_FROM	Mandatory	Example: 31234567
PORT_ID	Mandatory	Example: BTCM-VIVA-20101012-00001
DONOR_ID	Mandatory	Example: VIVA

FIELD	Optional/ Mandatory/ Empty/ Conditional	Remark
SUBSCRIPTION_NETWORK_ID	Mandatory	Example: BTCM
ORINATION_ID	Mandatory	
DESTINATION_ID	Mandatory	

4.5.16 Billing Resolution End (NpBillingResolutionEnd)

The Central System is transparent for this message. No information shall be added by the Central System, except for changing the ORINATION_ID and DESTINATION_ID.

FIELD	Optional/ Mandatory/ Empty/ Conditional	Remark
SERVICE_TYPE	Mandatory	"M"
MESSAGE_CODE	Mandatory	"NpBillingResolutionEnd"
NUMBER	Mandatory	Example: 31234567
PORT_ID	Mandatory	Example: BTCM-VIVA-20101012-00001
DONOR_ID	Mandatory	Example: VIVA
SUBSCRIPTION_NETWORK_ID	Mandatory	Example: BTCM
ORINATION_ID	Mandatory	
DESTINATION_ID	Mandatory	

4.5.17 Billing Resolution Received (NpBillingResolutionReceived)

The Central System is transparent for this message. No information shall be added by the Central System, except for changing the ORIGINATION_ID and DESTINATION_ID.

FIELD	Optional/ Mandatory/ Empty/ Conditional	Remark
SERVICE_TYPE	Mandatory	"M"
MESSAGE_CODE	Mandatory	"NpBillingResolutionReceived"
NUMBER	Mandatory	Example: 31234567
PORT_ID	Mandatory	Example: BTCM-VIVA-20101012-00001
DONOR_ID	Mandatory	Example: VIVA
SUBSCRIPTION_NETWORK_ID	Mandatory	Example: BTCM
ORIGINATION_ID	Mandatory	
DESTINATION_ID	Mandatory	

4.5.18 Billing Resolution Alert (NpBillingResolutionAlert)

The Central System is transparent for this message. No information shall be added by the Central System, except for changing the ORIGINATION_ID and DESTINATION_ID.

FIELD	Optional/ Mandatory/ Empty/ Conditional	Remark
SERVICE_TYPE	Mandatory	"M"
MESSAGE_CODE	Mandatory	"NpBillingResolutionAlert"
NUMBER	Mandatory	Example: 31234567
PORT_ID	Mandatory	Example: BTCM-VIVA-20101012-00001
DONOR_ID	Mandatory	Example: VIVA
SUBSCRIPTION_NETWORK_ID	Mandatory	Example: BTCM
RESOLUTION_LEVEL	Mandatory	Example: LEVEL1

FIELD	Optional/ Mandatory/ Empty/ Conditional	Remark
ORINATION_ID	Mandatory	
DESTINATION_ID	Mandatory	

4.6 Error Notifications

4.6.1 Structure of Message

FIELD	Optional/ Mandatory/ Empty/ Conditional	Form at	Description
MESSAGE_CODE	Mandatory	"Error Message"	
PORT_ID	Conditional: Mandatory if available (depending on the stage reached in the Porting Process) Empty otherwise	See Section 4.3 for field format	Provided by the Central System and used throughout the whole Porting Process. Example: BTCM-VIVA- 20101012-00001
REJECTED_MESSAGE_CODE	Mandatory	See Section 4.1 for NP message codes	Example: NpRequest
ERROR_CODE	Mandatory	ERRXXXX X=0-9 See Section 0 for Error Codes	The Central System will validate the codes against the list of predefined Error Codes. Example: ERR0002
COMMENTS	Conditional: Mandatory in case of ERROR_CODE: ERR0099 Optional otherwise	Free text field, 100 characters maximum	Text field for additional information which is not formalized in the message content.
ORINATION_ID	Mandatory	See Section 4.3 for field format	Example: VIVA or the Central System. This is the party that is originating the Error

Specification [1]: Number Portability Process Specification

FIELD	Optional/ Mandatory/ Empty/ Conditional	Form at	Description
			Notification.
DESTINATION_ID	Mandatory	See Section 4.3 for field format	Example: BTCM or the Central System. This must be the origination from which the initial faulty message was received.

4.6.2 Error Codes

Code	Text
ERR0001	Message format incorrect
ERR0002	Message out of sequence
ERR0003	Invalid Reject Code
ERR0004	Field SERVICE_TYPE not according to format
ERR0005	Field MESSAGE_CODE not according to format
ERR0006	Field NUMBER not according to format
ERR0007	Field NUMBER_FROM or NUMBER_TO not according to format (NPQuery)
ERR0008	SUBMISSION_ID not according to format
ERR0009	Field DATE_FROM not according to format
ERR0010	Field DATE_TO not according to format
ERR0011	Field PORT_ID not according to format
ERR0012	Field DONOR_ID not according to format
ERR0013	Field RECIPIENT_ID not according to format
ERR0014	Field ORIGINATION_ID not according to format
ERR0015	Field DESTINATION_ID not according to format
ERR0016	Field BLOCK_ID not according to format
ERR0017	Field SUBSCRIPTION_NETWORK_ID not according to format
ERR0018	Field OPERATOR_ID not according to format
ERR0019	Field NEW_ROUTE not according to format
ERR0020	<not assigned>
ERR0021	Field PORTING_DATE_TIME not according to format
ERR0022	Field REJECT_CODE not according to format
ERR0023	Field SIM_CARD_NUMBER not according to format
ERR0024	Field COMPANY_FLAG not according to format
ERR0025	Field CPR not according to format

Specification [1]: Number Portability Process Specification

Code	Text
ERR0026	Field COMMERCIAL_REG_NUMBER not according to format
ERR0027	Field PASSPORT_NUMBER not according to format
ERR0028	Field RESOLUTION_LEVEL not according to format
ERR0029	Unexpected or inconsistent data. See Chapter 7, Rules for the use of ERR0029
ERR0030	Message not sent within Billing Notification Period
ERR0031	Field Comment_1 not according to format
ERR0032	Billing Resolution Alert Error
ERR0099	OTHER- Reason included in COMMENTS field. (See Section 6: Procedure for the use of ERR0099)

5 Porting Conditions

This section describes in detail the Porting processes and each possible step to take in the Number Portability Process. Each step in the Preparation, Execution, Deactivation, Query and Billing Resolution procedures are defined by the following procedural stages:

prep(n) - Preparation procedure

exec(n) - Execution procedure

deac(n) - Deactivation procedure

quer(n) - Query procedure

bill(n) - Billing Resolution procedure

In addition, there are Time Intervals (Tn) defined between some of the procedural steps (e.g. T1).

Detailed process flow diagrams for each procedural stage can be seen in Section 5.6: Number Portability Procedure Flow Diagrams.

5.1 Preparation

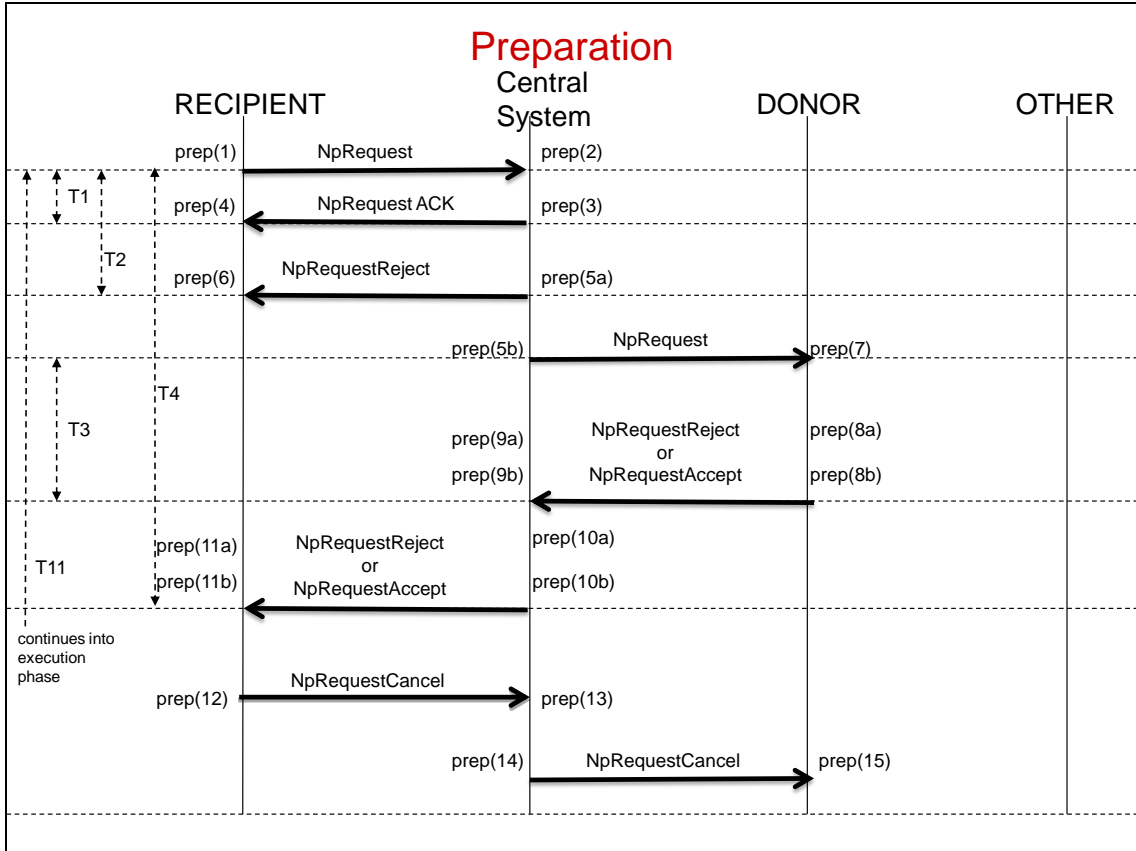

Figure 13 Preparation: process states and timers

prep(1): Process Stage prep(1) is the Recipient Operator sending the NpRequest message to the Central System

All fields in the Porting Request must be filled in according to the field definitions in Section 4 of this Specification.

- The Recipient Operator collects and provides data for the Porting Process as specified: Service Type, Message Code, Telephone Number, DONOR_ID, RECIPIENT_ID, Origination ID, Destination ID, SIM card number (SIM card number applies to Mobile Number Portability only).
- If the Subscriber is a private Subscriber the Recipient Operator sets the Company Flag to 'N', and provides the Subscriber's CPR and/or passport number. If no CPR exists then the passport number is mandatory. It is allowed to provide both. The Commercial Register Number field should be left empty for private Subscribers.
- If the Subscriber is a business Subscriber the Recipient Operator sets the Company Flag to "Y". The CPR and/or passport number of an authorized representative and the Commercial Register Number of the company must be provided. It is allowed to provide both the CPR and Passport number of an authorized company representative.
- If a Subscriber wishes to Port multiple Numbers (e.g. in the case of a company) then individual Requests for each Number should be submitted by the Recipient Operator's system to the Central System. This does not impact any processes between the Recipient and the Subscriber (e.g. the Recipient may accept a single form with multiple Numbers to be Ported, a single contract may be signed for multiple Numbers, etc). Each Number to be Ported will individually reach process stage prep(1). Multiple Porting Requests that have been submitted by a single Subscriber as one 'batch' will be assigned the same SUBMISSION_ID by the Recipient Operator. (Please see Section 8: Complex Porting Situations for further details).
- The Central System will process each Porting Request at the first opportunity to do so (e.g. if the Porting Request is submitted outside of the Porting Window, it will be processed as soon as the Porting Window is open). If a Subscriber wishes to Port a Number at some future date then the Recipient Operator holds the Porting Request and submits it when the requested Porting date has come within reach (i.e. maximum three days before the requested Porting date to account for 1 day Donor Operator response time and 2 day Porting Process time).

prep(2): Process Stage prep(2) is the Central System receiving the NpRequest message from the Recipient Operator

The Central System receives the NpRequest and validates the message and fields format:

- Timer T1 is started to track the time between sending the NpRequest and NpRequestAck messages by the Donor Operator.
- Timer T2 is started to track the time of the Central System checking on blocking issues: time between receiving the Porting Request at the Central System and the Central System replying with a NpRequestReject message (reject by the Central System).

- Timer T4 is started to track the time elapsed between the Central System receiving the NpRequest message and sending the NpRequestAccept / NpRequestReject messages (rejection by Donor Operator) to the Recipient Operator.
- Timer T11 is started to track the duration of the complete Porting Process: time between receiving the NpRequest message in the Central System until sending the NpExecuteComplete message from the Central System to the Recipient Operator.
- If the message cannot be read then the Central System will send an Error Notification containing Error Code ERR0001.
- If any of the fields in the NpRequest message is not according to the correct format then the Central System will send an Error Notification containing an Error Code referring to the field that is not compliant (e.g. If the DONOR_ID is incorrect, Error Code ERR0012 is sent by the Central System; if the CPR code is not the right length or format, then code ERR0025 is sent by the Central System). If several errors are found, then a like number of Error Notifications may be sent by the Central System.
- If an Error Notification is sent by the Central System , and received by the Recipient Operator, the Recipient Operator will revert to Process Stage prep(1).
- If all message fields are according to the required format, the Central System allocates a Port-ID (RECIPIENT_ID-DONOR_ID-YYYYMMDD-5 digit sequence number in the range of 00000-89999) and prepares the NpRequestAck message.

prep(3): Process Stage prep(3) is the Central System sending the NpRequestAck message to the Recipient Operator

- The Central System assigns a Port-ID and prepares the NpRequestAck message.
- The NpRequestAck message is sent by the Central System to the Recipient Operator.
- Timer T1 is stopped by the Central System.
- The Central System prepares for prep(5a)/prep(5b) by validating the message contents and applies (at least) the following validation rules. If any of the business rules is violated then the Central System will reach process stage prep(5a).
 - The Central System checks if a Porting Request is already in progress for the Number requested. If so, then Reject Code REJ0001 is sent.
 - The Central System checks if the service Type flag and the Number fields are compatible (e.g. Type = "M" and Number =3BCDEFGH). If not, then Reject Code REJ0004 is sent.
 - The Central System checks if the Donor Operator and the Recipient Operator are both applicable Licensees for the Type of Number requested for Porting. If not then Reject Codes REJ0002 or REJ0003 are sent.
 - The Central System checks the Ported Number Database to ensure that the Number requested for Porting is served by the Donor Operator. If not, then Reject Code REJ0005 is sent.
 - The Central System checks if the Number to be Ported is subject to a Billing Resolution Procedure. If this is the case, then Reject Code REJ0006 is sent.
 - The Central System checks the Company Flag. If the COMPANY_FLAG = N then CPR and/or Passport number should be provided. If not, then Reject Code REJ0012 is sent. If the COMPANY_FLAG = Y then the Commercial

Register Number should be provided. If not, then Reject Code 0017 is sent. In addition, a CPR and/or Passport number of an authorized representative should also be provided. If these details are not provided, then Reject Code REJ0012 is sent.

- If any of the business rules are violated then the Central System will reach Process Stage prep(5a).
- If no business rule is violated then the Central System will reach Process Stage prep(5b).

prep(4): Process Stage prep(4) is the Recipient Operator receiving the NpRequestAck message from the Central System

- The Recipient Operator conducts the following error checking on the message (known hereafter as “Message Error Check”). See Chapter 0 for the full list of Error Codes:
 - If the NpRequestAck message cannot be read the Recipient Operator will send an Error Notification containing Error Code ERR0001 to the Central System.
 - If the NpRequestAck message was not expected by the Recipient Operator, the Recipient Operator will send an Error Notification containing Error Code ERR0002 (“message out of sequence”) to the Central System.
 - If any of the fields in the NpRequestAck message are not according to the correct format then the Recipient Operator will send an Error Notification containing an Error Code referring to the field that is not compliant. If several errors are found, then a like number of Error Notifications may be sent by the Central System.
 - The Recipient Operator validates the content of the message. If the values are inconsistent or not according to the initial request then Error Code ERR0029 (“unexpected or inconsistent data”) is sent to the Central System.
- If an Error Notification is sent, the Central System shall go back to Process Stage prep(3).
- If no Error Notifications are sent, then the Recipient Operator processes the NpRequestAck, prepares for Process Stage prep(6) and awaits receiving the response to the Porting Request (ACCEPT or REJECT).

Note: these situations are somewhat theoretical as the Central System is not expected to make mistakes in the message fields, but any participant is able to send Error Notifications (see also Section 3.2).

prep(5a): Process Stage prep(5a) is the Central System sending the NpRequestReject message to the Recipient Operator

- The Central System prepares the NpRequestReject message by populating the following fields in the message, either automatically or from the NpRequest message:
 - the applicable Reject Code;
 - Port ID;
 - Service Type;

- NUMBER
 - SUBMISSION_ID
 - DONOR_ID
 - RECIPIENT_ID;
 - ORIGINATION_ID is set to the Central System; and
 - Destination_ID is set to the RECIPIENT_ID.
- The Central System sends the NpRequestReject to the Recipient Operator.
 - The Central System stops Timer T2.

prep(5b): Process Stage prep(5b) is the Central System sending the NpRequest message to the Donor Operator

- The Central System fills in the PORT_ID, replicates all data from the NpRequest received from the Recipient Operator and prepares the Porting Request message to be forwarded to the Donor Operator.
- The Central System Timer T3 is started to track the time between the Central System sending the NpRequest to the Donor Operator and receiving a response (NpRequestAccept or NpRequestReject).
- The NpRequest message is sent to the Donor Operator.

prep(6): Process Stage prep(6) is the Recipient Operator receiving the NpRequestReject message from the Central System (Rejection from the Central System)

- The Recipient Operator conducts a Message Error Check on the NpRequestReject message. If any errors are found, an Error Notification with the relevant Error Code is sent to the Central System.
- If an Error Notification is sent, the Central System shall go back to Process Stage prep(5a).
- If the message was correct then the Preparation process ends.
- The Recipient Operator may decide to start the process again at prep(1) by preparing a new Porting Request.

prep(7): Process Stage prep(7) is the Donor Operator receiving the NpRequest message from the Central System

- The Donor Operator conducts a Message Error Check on the NpRequest message. If any errors are found, an Error Notification with the relevant Error Code is sent to the Central System.
- In case an Error Notification was sent, then the Central System shall send the corrected message by prep (5b).
- The Donor Operator prepares for Process Stage prep (8a) and prep (8b) and validates the following set of rules :
 - The Donor Operator may repeat business rules that the Central System has applied (to verify that REJ001-REJ006, REJ012, and REJ017 do not apply). If any of these Reject Codes apply then the Donor Operator will start to prepare for prep (8a) and will make use of REJ0098.

- The Donor Operator checks if the Number is under a valid subscription. If not, then Reject Code REJ0008 is sent.
- If the provided SIM card number (ICCID, as printed on the SIM card) does not correspond to the provided number (and the Number has passed validation) then Reject Code REJ0010 is sent. This applies for Mobile Number Portability only.
- If the COMPANY_FLAG was wrongly set, then Reject Code REJ0007 is sent by the Donor Operator
- If the CPR was expected (since a CPR is registered with the Donor Operator) then Reject Code REJ0011 is sent.
- If the CPR in the message provided does not match the Subscriber records with the Donor Operator then Reject Code REJ0013 is sent.
- If the PASSPORT_NUMBER was expected (since a passport number is registered with the Donor Operator) then Reject Code REJ0015 is sent.
- If the passport number in the message provided does not match the Subscriber records with the Donor Operator then Reject Code REJ0014 is sent.
- If the Subscriber is a business Subscriber with the Donor Operator (COMPANY_FLAG='Y') and if the Commercial Register Number in the message provided does not match with the Subscriber records of the Donor Operator then Reject Code REJ0017 is sent.
- If the Subscriber that wishes to Port a Number has been issued an invoice for which the stated due date has passed, and the minimum amount of debt value is exceeded then the Donor Operator can reject the Porting Request for reasons of 'Bad Debt'.
Specifically the Reject Code (REJ0009) is sent if all of the following conditions apply:

1. A Porting Subscriber has been invoiced for unpaid fees, bills or other dues by the Donor Operator for charges directly related to its telephone services contract (the contract upon which the Subscriber has been allocated the Number to be Ported);
2. The invoiced amount equals or exceeds BHD 3/- at the date of the Porting Request ;
3. The Porting Subscriber has been notified by the Donor Operator about the invoiced unpaid fees, bills or other dues (by SMS, email, postal delivery or automatic call announcement)
4. The due date has passed.

Existing unpaid charges, whether billed or unbilled, which have not exceeded the due date are NOT considered 'Bad Debt', and are not allowed to lead to the use of Reject Code REJ0009 as the response to a Porting Request. However, these unpaid charges, –or charges that have later accumulated to or above BHD 3/-, can at a later stage lead to the initiation of the Billing Resolution Procedure (See Section 0 for further details).

- Reject Code REJ0099 is reserved for unexpected reject causes that cannot be covered by any of the listed causes. REJ0099 shall always be

accompanied with an explanation in the COMMENTS field. See chapter 5.6 for the procedure to be followed when using Reject Code REJ0099

- If any of the Donor business rules are violated then the Donor Operator will prepare for Process Stage prep(8a)
- If no Donor business rules are violated then the Donor Operator will prepare for Process Stage prep(8b)

prep(8a) Process Stage prep(8a) is the Donor Operator sending the NpRequestReject message to the Central System

- The Donor Operator prepares the NpRequestReject message by populating the following fields, either automatically or from the NpRequest message:
 - The applicable Reject Code;
 - Service Type;
 - Number TO/Number From;
 - DONOR_ID;
 - RECIPIENT_ID;
 - PORT_ID;
 - SUBMISSION_ID
 - ORIGINATION_ID which is set to DONOR_ID; and
 - Destination _ID which is set to the RECIPIENT_ID.
- The Donor Operator sends the NpRequestReject message to the Central System.

prep(8b) Process Stage prep(8b) is the Donor Operator sending the NpRequestAccept message to the Central System

- The Donor Operator prepares the NpRequestAccept message by populating the following fields, either automatically or from the NpRequest message:
 - Service Type;
 - Number TO/Number From;
 - DONOR_ID;
 - RECIPIENT_ID;
 - PORT_ID;
 - ORIGINATION_ID which is set to DONOR_ID; and
 - Destination _ID which is set to the RECIPIENT_ID.
- Donor Operator sends the NpRequestAccept message out to the Central System.

prep(9a): Process Stage prep(9a) is the Central System receiving the NpRequestReject message from the Donor Operator

The Central System receives the NpRequestReject message and validates the message and data fields' format:

- Timer T3 is stopped

- The Central System conducts a Message Error Check on the NpRequestReject message. If any errors are found, an Error Notification with the relevant Error Code is sent to the Donor Operator.
- If an Error Notification is sent by the Central System, and received by the Donor Operator, the Donor Operator will go back to Process Stage prep(8a).
- If all message fields are correct then the Central System prepares for Process Stage prep (10a) to send the NpRequestReject message to the Recipient Operator.

NOTE: The Central System can only move from Process Stage prep(9a) to prep(10a) and from Process Stage prep(9b) to prep(10b). In other words, it will not replace the NpRequestReject message as sent by the Donor Operator into a NpRequestAccept message or vice versa.

prep(10a): Process Stage prep (10a) is the Central System sending the NpRequestReject message to the Recipient Operator

- The Central System sends the NpRequestReject message to the Recipient Operator.
- Timer T4 is stopped.

prep(9b): Process Stage prep (9b) is the Central System receiving the NpRequestAccept message from the Donor Operator

The Central System receives the NpRequestAccept message and validates the message and data field format:

- Timer T3 is stopped.
- The Central System conducts a Message Error Check on the NpRequestAccept message. If any errors are found, an Error Notification with the relevant Error Code is sent to the Donor Operator.
- If an Error Notification is sent by the Central System, and received by the Donor Operator, the Donor Operator will go back into Process Stage prep(8b).
- If all message fields are correct the Central System prepares for Process Stage prep(10b) to send the NpRequestAccept message to the Recipient Operator.

NOTE: The Central System can only move from Process Stage prep(9a) to prep(10a) and from Process Stage prep(9b) to prep(10b). In other words, it will not replace the NpRequestReject message as sent by the Donor Operator into a NpRequestAccept message or vice versa.

prep(10b): Process Stage prep(10b) is the Central System sending the NpRequestAccept message to Recipient Operator

- The Central System sends the NpRequestAccept message to the Recipient Operator.
- Timer T4 is stopped.

prep(11a): Process Stage prep(11a) is the Recipient Operator receiving the NpRequestReject message from the Central System (Rejection by the Donor Operator)

- The Recipient Operator conducts a Message Error Check on the NpRequestReject message. If any errors are found, an Error Notification with the relevant Error Code is sent to the Central System.
- If an Error Notification message is sent, then the Central System will go back to Process Stage prep(10a).

- In case no Error Notifications have been sent, then the end of the Preparation process has been reached. The Recipient Operator may decide to start the process again at Process Stage prep(1) by submitting a new Porting Request.

prep(11b): Process Stage prep(11b) is the Recipient Operator receiving the NpRequestAccept message from the Central System

- The Recipient Operator conducts a Message Error Check on the NpRequestAccept message. If any errors are found, an Error Notification with the relevant Error Code is sent to the Central System.
- If an Error Notification message is sent, then the Central System will go back to Process Stage prep(10b).
- If no Error Notification is sent then the Recipient Operator will prepare for Process Stages prep(12) or exec(1).

prep(12): Process Stage prep(12) is the Recipient Operator sending the NpRequestCancel message to the Central System

- The Recipient Operator collects and provides data for the Porting cancellation process from the NpRequest message that was accepted, after which the Recipient Operator reached process stage prep(11b).
- The Recipient Operator sends the NpRequestCancel message to the Central System.
- If no Error Notifications are received then the Recipient Operator has reached the end of the process. The Recipient Operator may decide to start the process again at Process Stage prep(1) by submitting a new Porting Request

prep(13) : Process Stage prep(13) is the Central System receiving the NpRequestCancel message from the Recipient Operator

- The Central System conducts a Message Error Check on the NpRequestCancel message. If any errors are found, an Error Notification with the relevant Error Code is sent to the Recipient Operator.
- If an Error Notification message is sent, then the Recipient Operator will go back to Process Stage prep(12).
- If no Error Notifications are sent then the Central System will prepare for Process Stage prep(14).

prep(14): Process Stage prep(14) is the Central System sending the NpRequestCancel message to the Donor Operator

- The Central System collects the required data and prepares the NpRequestCancel message.
- The NpRequestCancel message is sent to the Donor Operator.

prep(15): Process Stage prep(15) is the Donor Operator receiving the NpRequestCancel message from the Central System

- The Donor Operator conducts a Message Error Check on the NpRequestCancel message. If any errors are found, an Error Notification with the relevant Error Code is sent to the Central System.
- If an Error Notification message is sent, then the Central System will go back to Process Stage prep(14).

- If no Error Notifications are sent then the end of the Preparation process has been reached.

5.2 Execution

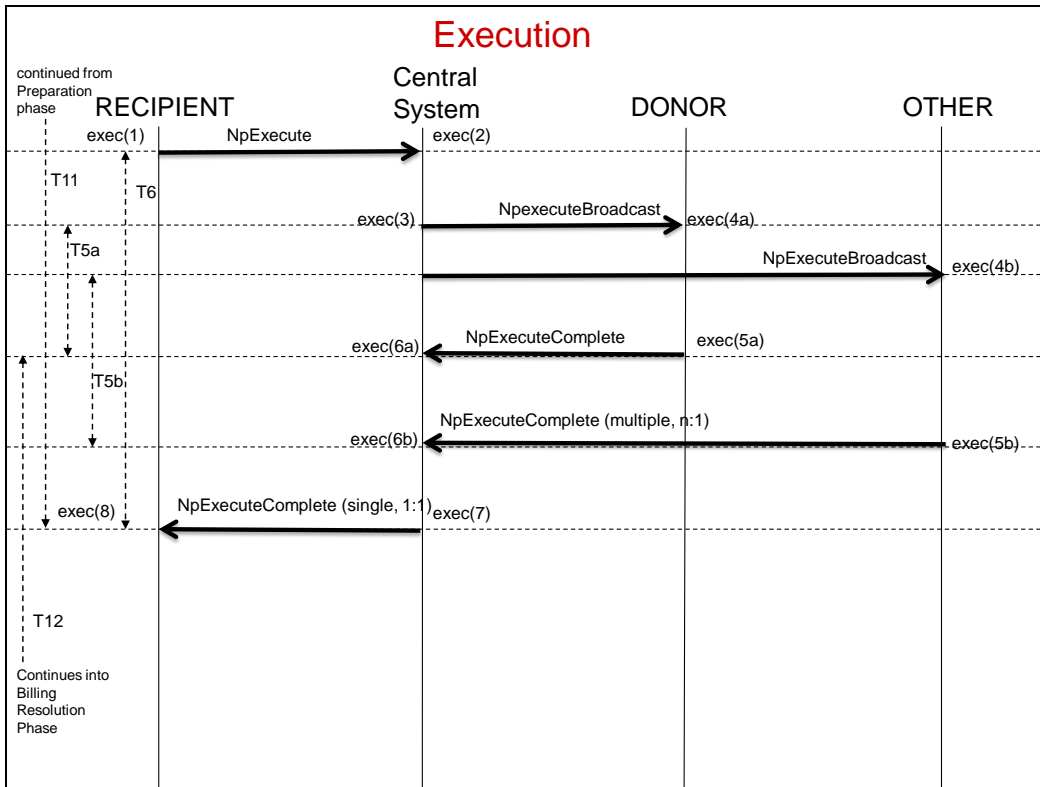

Figure 14 Execution: Process states and timers

exec(1): Process Stage **exec(1)** is the start of the Execution phase, with the Recipient Operator sending a **NpExecute** message to the Central System

- Within the defined Porting timeframe the Recipient Operator connects the Number on its' network and systems.
- The Recipient Operator collects information as exchanged during the Preparation phase and prepares the **NpExecute** message.
- The **NpExecute** message is sent to the Central System.

exec(2): Process Stage **exec(2)** is the Central System receiving the **NpExecute** message from the Recipient Operator

- The Central System conducts a Message Error Check on the **NpExecute** message. If any errors are found, an Error Notification with the relevant Error Code is sent to the Recipient Operator.
- If an Error Notification message is sent, then the Recipient Operator will go back to Process Stage **exec(1)**.

- If no Error Notifications are sent, the Central System starts Timer T6 to measure the time of the Execution phase (which is the time between the Central System receiving the NpExecute message from the Recipient Operator and sending back the NpExecuteComplete message).
- The Central System will prepare for Process Stage exec(3).

exec(3): Process Stage exec(3) is the Central System sending the NpExecuteBroadcast message to the Donor Operator and all other Operators

- The Central System prepares the NpExecuteBroadcast message with the following information:
 - NEW_ROUTE: the Routing Number associated with the Recipient Operator (see Section 4.4 for Operator Codes and associated Routing Numbers.)
- The Central System sends the NpExecuteBroadcast to the Donor Operator and all other Operators.
- The Central System starts Timers T5a and T5b to measure the time between sending the NpExecuteBroadcast message to the Donor Operator/other Operators and receiving the NpExecuteComplete message from the Donor Operator/other Operators.

exec(4a): Process Stage exec(4a) is the Donor Operator receiving the NpExecuteBroadcast message from the Central System

- The Donor Operator conducts a Message Error Check on the NpExecuteBroadcast message. If any errors are found, an Error Notification with the relevant Error Code is sent to the Central System.
- If an Error Notification is sent then the Central System will go back to Process Stage exec(3).
- If all fields in the message were correct then the Donor Operator disconnects the Number from its' network and systems and updates its' routing tables for the new Subscription Network (Recipient Operator network).
- The Donor Operator will proceed to Process Stage exec(5a).

exec(4b): Process Stage exec(4b) is the other Operators receiving the NpExecuteBroadcast message from the Central System

- The other Operators conduct a Message Error Check on the NpExecuteBroadcast message. If any errors are found, an Error Notification with the relevant Error Code is sent to the Central System.
- If an Error Notification is sent, then the Central System will revert to Process Stage exec(3).
- If all message fields were correct then the other Operators update their routing tables and systems with the new Subscription Network (Recipient Operator network) ID corresponding to the Ported Number.
- The other Operators will proceed to Process Stage exec(5a).

exec(5a): Process Stage exec(5a) is the Donor Operator sending a NpExecuteComplete message to the Central System

- After having disconnected the Number from its' network and systems and updating the routing tables for the new Subscription Network (Recipient Operator) corresponding to the Ported Number, the Donor Operator replies to the NpExecuteBroadcast with a NpExecuteComplete message.

exec(5b): Process Stage exec(5b) is the other Operators sending a NpExecuteComplete message to the Central System

- After having updated its' routing tables and systems for the new Subscription Network (Recipient Operator), the other Operators reply to the NpExecuteBroadcast with a NpExecuteComplete message.

exec(6a): Process Stage exec(6a) is the Central System receiving the NpExecuteComplete message from the Donor Operator

- The Central System conducts a Message Error Check on the NpExecuteComplete message. If any errors are found, an Error Notification with the relevant Error Code is sent to the Donor Operator.
- If an Error Notification is sent, the Donor Operator will go back to Process Stage exec(5a).
- Once the Central System has received the NpExecuteComplete message from the Donor Operator (default setting) and no Error Notification has been sent then the Central System starts Timer T12 and stops Timer T5a.
- The Central System prepares for Process Stage exec(7).

exec(6b): Process Stage Exec (6b) is the Central System receiving the NpExecuteComplete messages from the Other operators.

- The Central System conducts a Message Error Check on the NpExecuteComplete message. If any errors are found, an Error Notification with the relevant Error Code is sent to the other Operator.
- If an Error Notification is sent, the other Operator will go back to Process Stage exec(5b). The Central System stops Timer T5b. The Central System also keeps track of receiving NpExecuteComplete messages from Other Operator operators. If no NpExecuteComplete messages are received then this will appear in the Central System reports as the timer expires.

exec(7): Process Stage exec(7) is the Central System sending a NpExecuteComplete message to the Recipient Operator

- After having received the necessary Porting executed messages, the Central System will prepare a NpExecuteComplete message for the Recipient Operator. This means that the Central System will receive more than one NpExecuteComplete message, but the Recipient Operator will receive a single message.

Note: It is a matter of configuration for how many participants the Central System will wait to receive the NpExecuteComplete from. The minimum (default) is the Donor Operator alone.

- The Central System will collect the necessary information, prepare and send a Porting Executed message to the Recipient Operator.
- Timers T6 and T11 are stopped.

exec(8): Process Stage exec(8) is the Recipient Operator receiving the NpExecuteComplete message from the Central System

- The Recipient Operator conducts a Message Error Check on the NpExecuteComplete message. If any errors are found, an Error Notification with the relevant Error Code is sent to the Central System.
- If an Error Notification is sent, the Central System will go back to Process Stage exec(7).
- If all message fields were correct then the end of the Execution process has been reached.

5.3 Deactivation

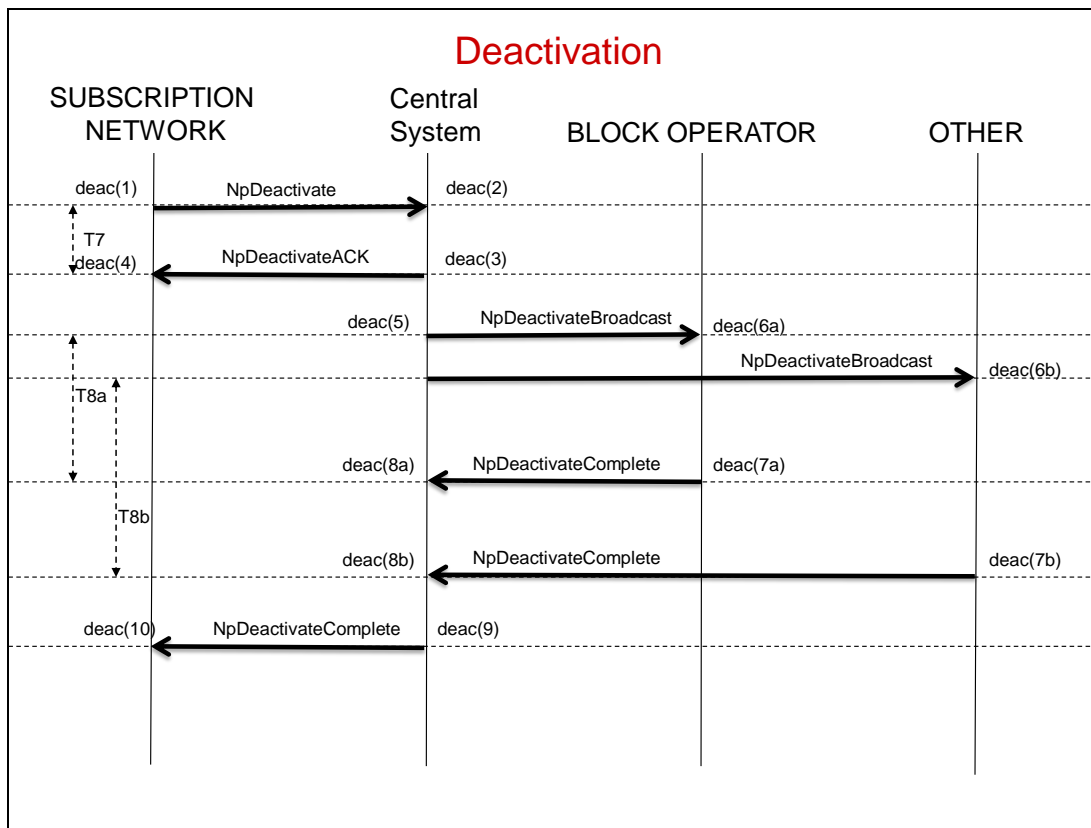

Figure 15 Deactivation: Process states and timers

deac(1): Process Stage deac(1) is the Subscription Network sending a NpDeactivate message to the Central System

- If a Number has been Ported in the past and the Subscription Network disconnects the Number, then the Number will return to the Block Operator. The Block Operator and other Operators shall be informed about this through the Deactivation procedure.
- The Subscription Network shall collect the necessary information which includes the Number which is disconnected. The Subscription Network sends a NpDeactivate message to the Central System, taking into account the Return Period, which is the time allowed to return a Number to the Number Range holder (Block Operator) after a (previously Ported) Number has been disconnected. The Return period is 30 days at maximum.
- The Subscription Network will wait for Process Stage deac(4).

deac(2): Process Stage deac(2) is the Central System receiving the NpDeactivate message from the Subscription Network

- The Central System conducts a Message Error Check on the NpDeactivate message. If any errors are found, an Error Notification with the relevant Error Code is sent to the Subscription Network.
- If an Error Notification is sent, the Subscription Network may revert to Process Stage deac(1).
- If all message fields are correct then Timer T7 is started to measure the time between receiving the NpDeactivate message in the Central System and sending the NpDeactivationAck message to the Subscription Network.
- The Central System moves to Process Stage deac(3).

deac(3): Process Stage deac(3) is the Central System sending a NpDeactivateAck message to the Subscription Network.

- The Central System collects the information SUBSCRIPTION_NETWORK_ID (is the same as SUBSCRIPTION NETWORK) and BLOCK_ID.
- The Central System assigns a PORT_ID which consists of BLOCK_ID-SUBSCRIPTION_NETWORK_ID-DDMMYYYY-5 digit sequence Number in the range of 90000-99999.
- The Central System sends the NpDeactivateAck message to the Subscription Network.
- Timer T7 is stopped.
- The Central System moves to Process Stage deac(5).

deac(4): Process Stage deac(4) is the Subscription Network receiving the NpDeactivateAck message from the Central System

- The Subscription Network conducts a Message Error Check on the NpDeactivateAck message. If any errors are found, an Error Notification with the relevant Error Code is sent to the Central System.
- If an Error Notification is sent, the Central System will revert to Process Stage deac(3).

- If all message fields were correct, then the Subscription Network will wait for Process Stage deac(10).

deac(5): Process stage deac(5) is the Central System sending a NpDeactivateBroadcast to the Block Operator and other Operators

- The Central System prepares the NpDeactivateBroadcast message for the Block Operator and other Operators.
- The Central System sends the NpDeactivateBroadcast message to the Block Operator and other Operators.
- Timers T8a and T8b are started, measuring the time between sending the NpDeactivateBroadcast message and receiving a response from the Donor Operator/other Operators.
- By default at least the Block Operator should reply with the NpDeactivateComplete message in order to continue with Process Stage deac(9).

deac(6a): Process Stage deac(6a) is the Block Operator receiving a NpDeactivateBroadcast message from the Central System

- The Block Operator conducts a Message Error Check on the NpDeactivateBroadcast message. If any errors are found, an Error Notification with the relevant Error Code is sent to the Central System.
- If an Error Notification is sent, the Central System will revert to Process Stage deac(5).
- The Block Operator will update its' network and systems accordingly and then proceed to Process Stage deac(7a).
- The Number is returned to the Block Operator. The Block Operator will be able to reuse the Number after any applicable freeze period.

deac(6b): Process Stage deac(6b) is the other Operators receiving the NpDeactivateBroadcast message from the Central System

- The other Operators conduct a Message Error Check on the NpDeactivateBroadcast message. If any errors are found, an Error Notification with the relevant Error Code is sent to the Central System.
- If an Error Notification is sent, the Central System will revert to Process Stage deac(5).
- If all message fields are correct then the other Operators will update its' network and systems accordingly and proceed to Process Stage deac(7b).

deac(7a): Process Stage deac(7a) is the Block Operator sending a NpDeactivateComplete message to the Central System

- After having updated its' network and systems, the Block Operator sends a NpDeactivateComplete message to the Central System.

deac(7b): Process Stage deac(7b) is the other Operators sending a NpDeactivateComplete message to the Central System

- After having updated its' network and systems, the other Operators will send a NpDeactivateComplete message to the Central System.

deac(8a): Process Stage deac(8a) is the Central System receiving the NpDeactivateComplete message from the Block Operator

- The Central System conducts a Message Error Check on the NpDeactivateComplete message. If any errors are found, an Error Notification with the relevant Error Code is sent to the Block Operator.
- If an Error Notification is sent, the Block Operator/other Operators will revert to Process Stage deac(7a)/deac(7b).
- Timer T8a is stopped.
- Once the Central System has received the NpDeactivateComplete message from at least the Block Operator (default setting) then the Central System prepares for Process Stage deac(9).

deac(8b): Process Stage deac(8b) is the Central System receiving the NpDeactivateComplete message from the other Operators

- The Central System conducts a Message Error Check on the NpDeactivateComplete message. If any errors are found, an Error Notification with the relevant Error Code is sent to the other Operators.
- If an Error Notification is sent, the other Operators will revert to Process Stage deac(7b).
- Timer T8b is stopped.
- By default a NpDeactivateComplete message should be received from at least the Block Operator in order to continue to Process Stage deac(9).
- The Central System keeps track of all received NpDeactivateComplete messages.

deac(9): Process Stage deac(9) is the Central System sending a NpDeactivateComplete message to the Subscription Network.

- The Central System prepares the NpDeactivateComplete message.
- The NpDeactivateComplete message is sent from the Central System to the Subscription Network.

deac(10): Process Stage deac(10) is the Subscription Network receiving the NpDeactivateComplete message from the Central System

- The Subscription Network conducts a Message Error Check on the NpDeactivateComplete message. If any errors are found, an Error Notification with the relevant Error Code is sent to the Central System.
- If an Error Notification is sent, the Central System will revert to Process Stage deac(9).
- If all message fields are correct then the end of the Deactivation process has been reached.

5.4 Query

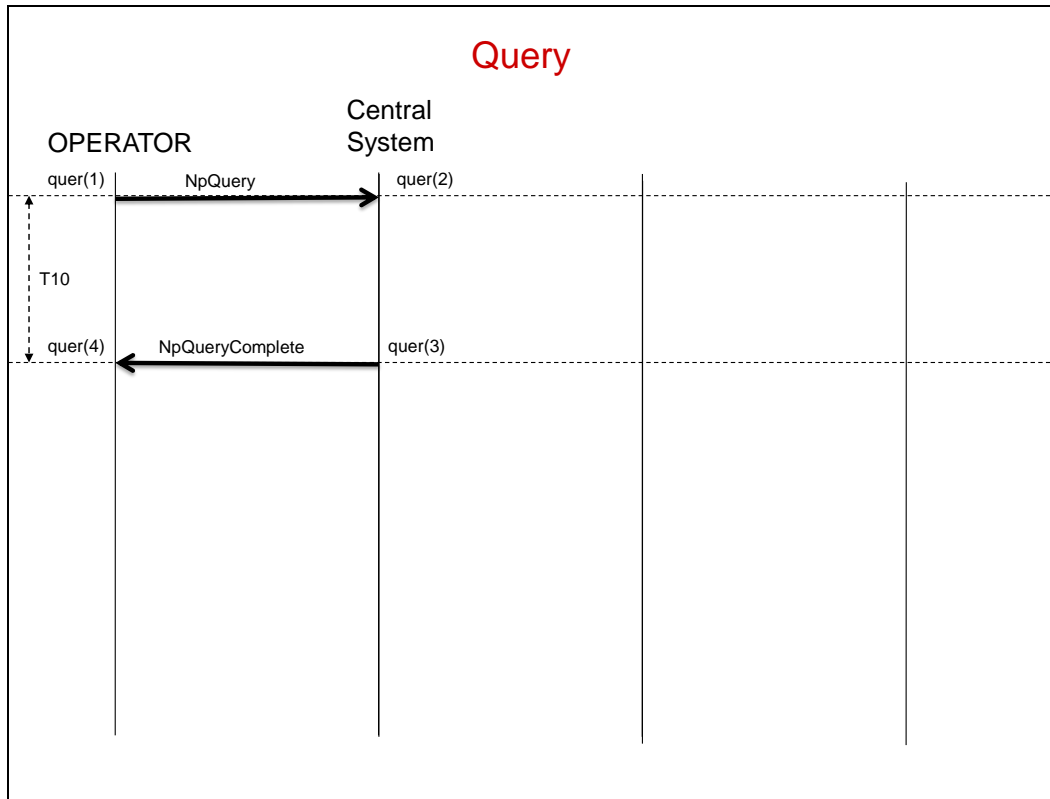

Figure 16 Query: Process states and timers

quer(1): Process Stage quer(1) is the Operator sending a NpQuery message to the Central System

- When an Operator wishes to obtain an extract of the Ported Number Database then this will be requested from the Central System via a NpQuery message.
- Depending on the Operator's needs:
 - All Number Ports within a certain time span can be obtained by filling in the DATE_FROM and DATE_TO fields. If not populated, then the whole Ported Number Database is prepared.
 - And/or all Number Ports within a certain Number Range can be obtained by filling in the NUMBER_FROM and NUMBER_TO fields. If these fields are not populated, then a all Ported Numbers of all ranges are prepared.
 - And/or if Ported Numbers to a certain operator are required, then this is specified in the field OPERATOR_ID. When left empty, then the Central System assumes all operators.

quer(2): Process Stage quer(2) is the Central System receiving the NpQuery message from the Operator

- The Central System conducts a Message Error Check on the NpQuery message. If any errors are found, an Error Notification with the relevant Error Code is sent to the Operator.
- If an Error Notification is sent, the Operator can revert to Process Stage quer(1).
- If the message and fields are correct then Timer T10 is started to measure the time between the Central System receiving the NpQuery and replying with a NpQueryComplete message.
- The Central System starts preparing a file containing the requested Ported Number Database extract in the NpQuery.
- The Central System moves to Process Stage quer(3) once the Ported Number Database extract has been stored in a designated directory.

quer(3): Process Stage quer(3) is the Central System sending a NpQueryComplete message to the Operator

- When the Central System has prepared the Ported Number Database extract available to the Operator, the Central System will notify the Operator with a NpQueryComplete message.
- Timer T10 is stopped.

quer(4): Process Stage quer(4) is the Operator receiving the NpQueryComplete message from the Central System

- The Operator conducts a Message Error Check on the NpQueryComplete message. If any errors are found, an Error Notification with the relevant Error Code is sent to the Central System.
- If an Error Notification is sent, the Central System will revert to Process Stage quer(3).
- The Operator can obtain the requested file from the designated directory at the Central System.
- Once the Operator receives the requested query data, the end of the Query process has been reached.

5.5 Billing Resolution

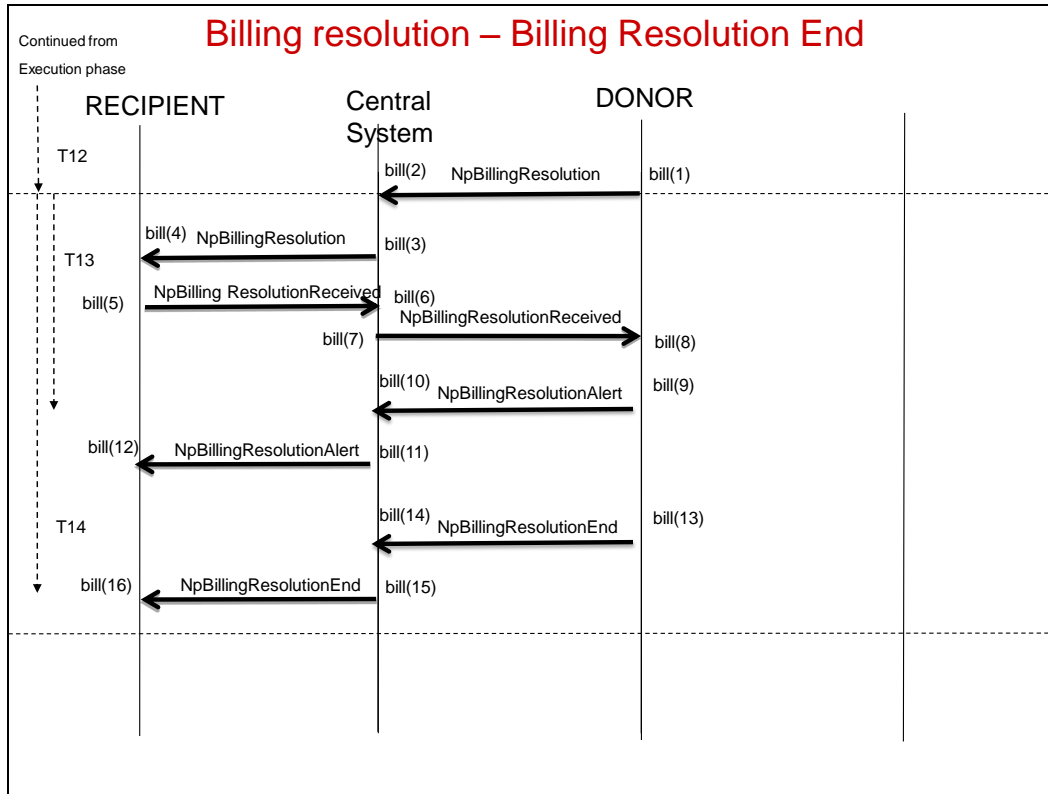

Figure 17 Billing Notification: Process states and timers –Billing Resolution End

bill(1): Process Stage bill(1) is the Donor Operator sending a NpBillingResolution message to the Central System

- If, within the Billing Notification period (Please refer to Section 10 for further details), the Subscriber still has Bad Debt with the Donor Operator, then the Donor Operator is entitled to submit a Billing Resolution message to the Recipient Operator.
- The Donor Operator collects the data required for this message (i.e. the Port-ID corresponding to the initial Porting Request) and submits the message to the Central System.

bill(2): Process Stage bill(2) is the Central System receiving a NpBillingResolution message from the Donor Operator

- The Central System conducts a Message Error Check on the NpBillingResolution message. If any errors are found, an Error Notification with the relevant Error Code is sent to the Donor Operator.
- If Timer T12 has not exceeded one calendar month or has expired (see Section 10 for Billing Notification Period), then Error Code ERR0030 ("Message not sent within Billing Notification Period") is sent to the Donor Operator.

- If an Error Notification is sent, the Donor Operator can revert to Process Stage bill(1).
- The Central System raises a flag for the Number to indicate that it is the subject of a Billing Resolution process.
- Timers T13 and T14 are started.
- The Central System proceeds to Process Stage bill(3).

bill(3): Process Stage bill(3) is the Central System sending the NpBillingResolution to the Subscription Network

- The Central System forwards the NpBillingResolution message to the Subscription Network. The message is not changed by the Central System.
- The Central System prepares for Process Stage bill(6).

bill(4): Process Stage bill(4) is the Subscription Network receiving the NpBillingResolution message from the Central System

- The Subscription Network conducts a Message Error Check on the NpBillingResolution message. If any errors are found, an Error Notification with the relevant Error Code is sent to the Central System.
- If an Error Notification is sent, the Central System can revert to Process Stage bill(3).
- If no Error Notifications have been sent then the Subscription Network will flag the Number as being at Resolution Level 1.
- The Subscription Network will execute Process Stage bill(5) and prepare for Process Stage bill(12) or bill(15).

bill(5): Process Stage bill(5) is the Subscription Network sending the NpBillingResolutionReceived message to the Central System

- The Subscription Network sends the NpBillingResolutionReceived message to the Central System as the confirmation that NpBillingResolution was received by the Subscription Network.

bill(6): Process Stage bill(6) is the Central System receiving the NpBillingResolutionReceived message from the Subscription Network

- The Central System receives NpBillingResolutionReceived message that was sent by the Subscription Network.
- The Subscription Network conducts a Message Error Check on the NpBillingResolution message. If any errors are found, an Error Notification with the relevant Error Code is sent to the Central System.
- If no Error Notifications have been sent then the Central System will proceed with Process Stage bill(7).

bill(7): Process Stage bill(7) is the Central System sending the NpBillingResolutionReceived to the Donor Operator

- The Central System sends the NpBillingResolutionReceived message to the Donor Operator.

bill(8): Process Stage bill(8) is the Donor Operator receiving the NpBillingResolutionReceived message from the Central System

- The Donor Operator conducts a Message Error Check on the NpBillingResolutionReceived message. If any errors are found, an Error Notification with the relevant Error Code is sent to the Central System.
- If no Error Notifications have been sent then the Donor Operator prepares for Process Stages bill(9) or bill(13).

bill(9): Process Stage bill(9) is the Donor Operator sending the NpBillingResolutionAlert message to the Central System

- The Donor Operator may escalate the process by sending the NpBillingResolutionAlert message
- The Donor Operator has to specify which level in the degradation process is applicable in the field RESOLUTION_LEVEL. The degradation should go in fixed order from Level 1 to Level 2 to Level 3. The first Level is LEVEL1.

bill(10): Process Stage bill(10) is the Central System receiving the NpBillingResolutionAlert message from the Donor Operator

- The Central System conducts a Message Error Check on the NpBillingResolutionAlert message. If any errors are found, an Error Notification with the relevant Error Code is sent to the Donor Operator.
- If Timer T13 has not expired then the Central System will respond with an Error Notification containing Error Code ERR0032 (“Billing Resolution Alert Error”). The Donor Operator can revert to Process Stage bill(9).
- If Timer T14 has already expired, then the Central System will respond to the Donor Operator with an Error Notification containing Error Code ERR0032 (“Billing Resolution Alert Error”) and proceed to Process Stage bill(15).
- If the Resolution Level in the NpBillingResolutionAlert message is not the next sequential Alert message then the Central System will respond with an Error Notification containing Error Code ERR0032 (“Billing Resolution Alert Error”). The Donor Operator can revert to Process Stage bill(9).
- If the message and fields are correct and no Error Notifications have been sent then the Central System moves to stage bill(11). Timers T13 and T14 are reset.

bill(11): Process Stage bill(11) is the Central System sending the NpBillingResolutionAlert message to the Subscription Network

- The Central System forwards the NpBillingResolutionAlert message to the Subscription Network.

bill(12): Process Stage bill(12) is the Subscription Network receiving the NpBillingResolutionAlert from the Central System

- The Subscription Network conducts a Message Error Check on the NpBillingResolutionAlert message. If any errors are found, an Error Notification with the relevant Error Code is sent to the Central System.
- If an Error Notification is sent, then the Central System can revert to Process Stage bill(11).
- If the message and fields are correct and no Error Notifications have been sent then the Recipient Operator increases the Alert Level of the Number to the next Level as specified by the NpBillingResolutionAlert message.

- The Subscription Network will execute one of the following actions:
 - If the current Resolution Level of the Number is Level 1 or Level 2, the Subscription Network will apply the next level of service degradation. The Subscription Network prepares for either Process Stage bill(12) again or Process Stage bill(15).
 - If the current Resolution Level of the Number is Level 3, the Subscription Network will proceed to Process Stage deac(1).

Note: Process Stages bill(9) through bill(12) can be repeated a maximum of three times for a particular instance of NpBillingResolution.

bill(13): Process Stage bill(13) is the Donor Operator sending the NpBillingResolutionEnd message to the Central System

- If the Subscriber has cleared all outstanding bills as stated in Process Stage bill(1), then the Billing Resolution Process can be ended by sending a NpBillingResolutionEnd message
- The Donor Operator sends a NpBillingResolutionEnd message to the Central System

bill(14): Process Stage bill(14) is the Central System receiving the NpBillingResolutionEnd from the Donor Operator

- The Central System conducts a Message Error Check on the NpBillingResolutionEnd message. If any errors are found, an Error Notification with the relevant Error Code is sent to the Donor Operator.
- If an Error Notification is sent, then the Donor Operator can revert to Process Stage bill(9).
- If the message and fields are correct and no Error Notifications have been sent then the Central System moves to stage bill(15) and Timers T12, T13 and T14 are stopped. The Central System will remove the flag on the Number to indicate that it is no longer the subject of a Billing Resolution process.

bill(15): Process Stage bill(15) is the Central System sending the NpBillingResolutionEnd message to the Subscription Network

- The Central System sends the NpBillingResolutionEnd message to the Subscription Network. The message is not changed by the Central System.

bill(16): Process Stage bill(16) is the Recipient Operator receiving the NpBillingResolutionEnd message from the Central System

- The Subscription Network conducts a Message Error Check on the NpBillingResolutionEnd message. If any errors are found, an Error Notification with the relevant Error Code is sent to the Central System.
- If an Error Notification is sent, then the Central System can revert to Process Stage bill(15).
- If the message and fields are correct and no Error Notifications have been sent then the Subscription Network restores service to the Ported Number as per the contractual agreements between the Subscription Network and the Subscriber.
- The end of the Billing Resolution process has been reached

5.6 Number Portability Procedure Flow Diagrams

PORTING PREPARATION

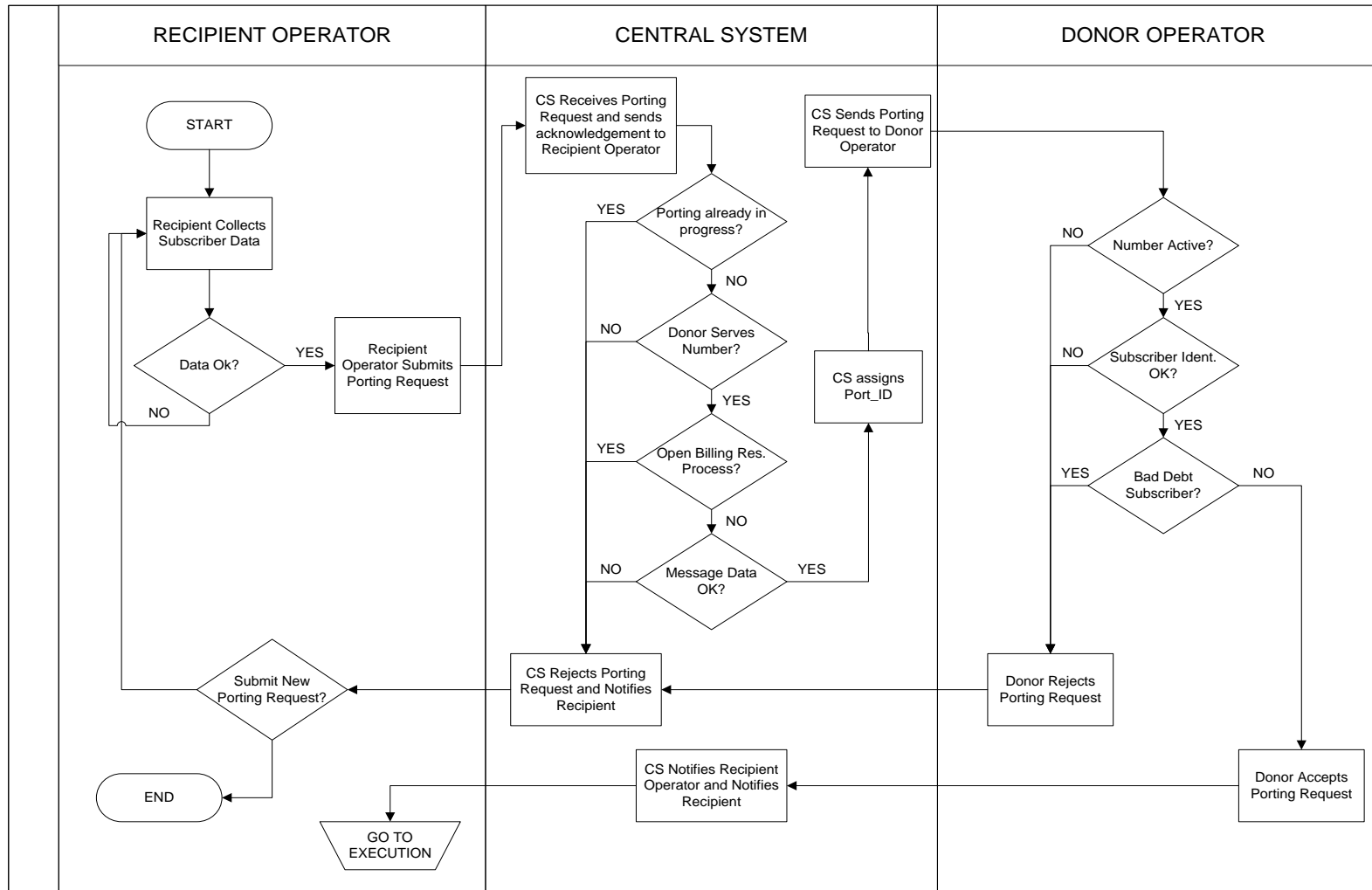

Figure 18: Porting Preparation Process Flow Diagram

PORTING EXECUTION

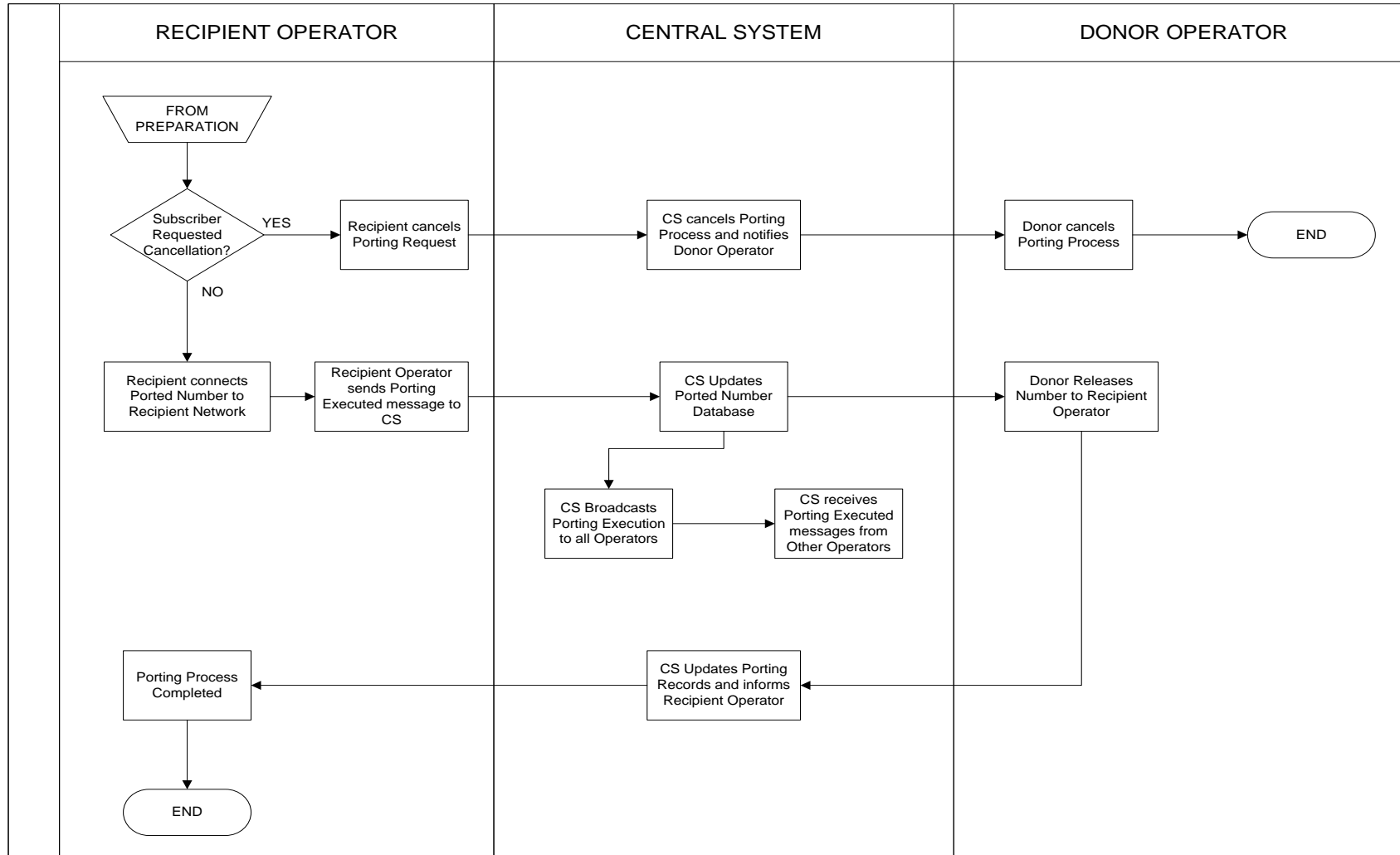

Figure 19: Porting Execution Process Flow Diagram

DEACTIVATION

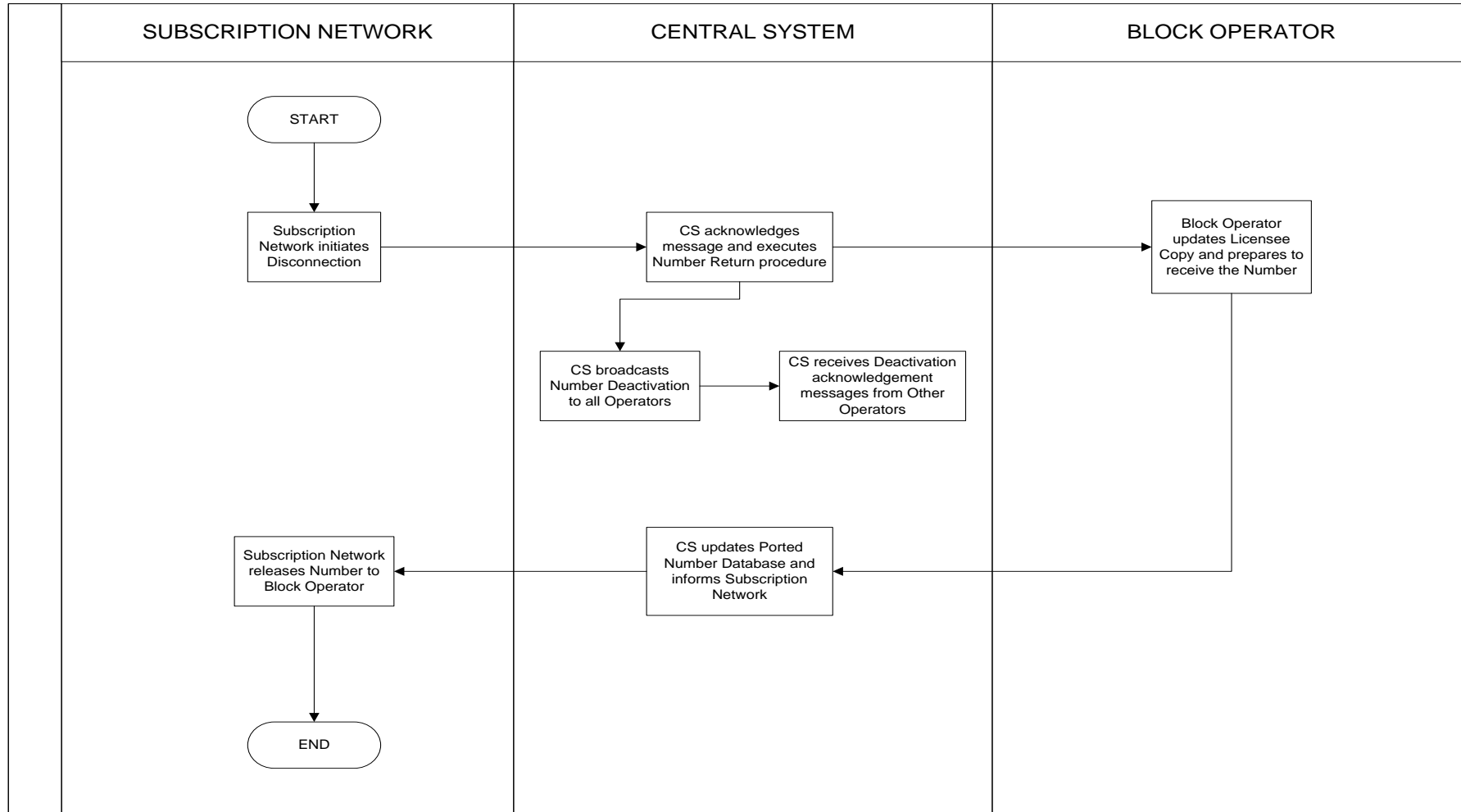

Figure 20: Deactivation Process Flow Diagram

NP QUERY

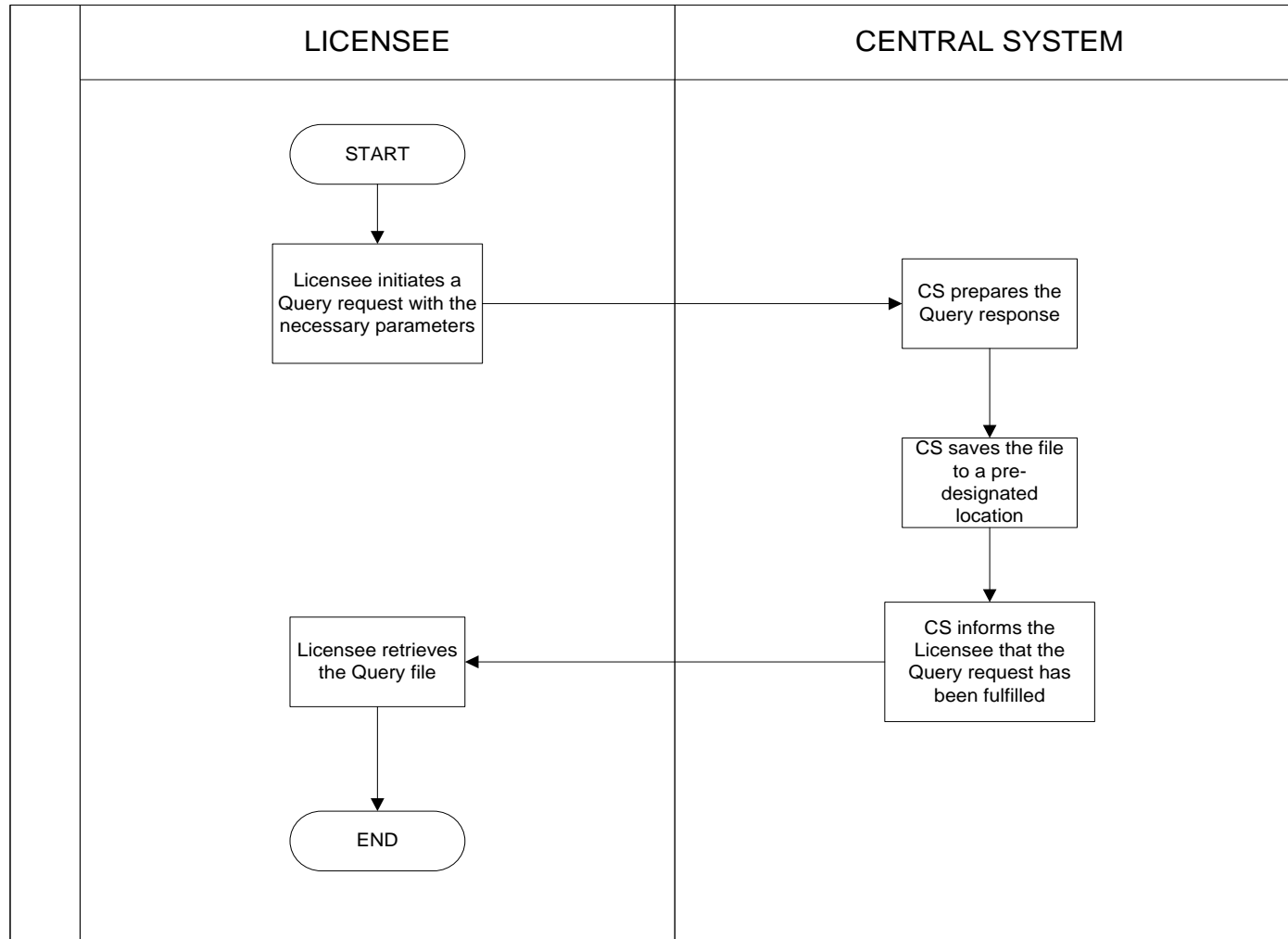

Figure 21: NP Query Process Flow Diagram

BILLING RESOLUTION

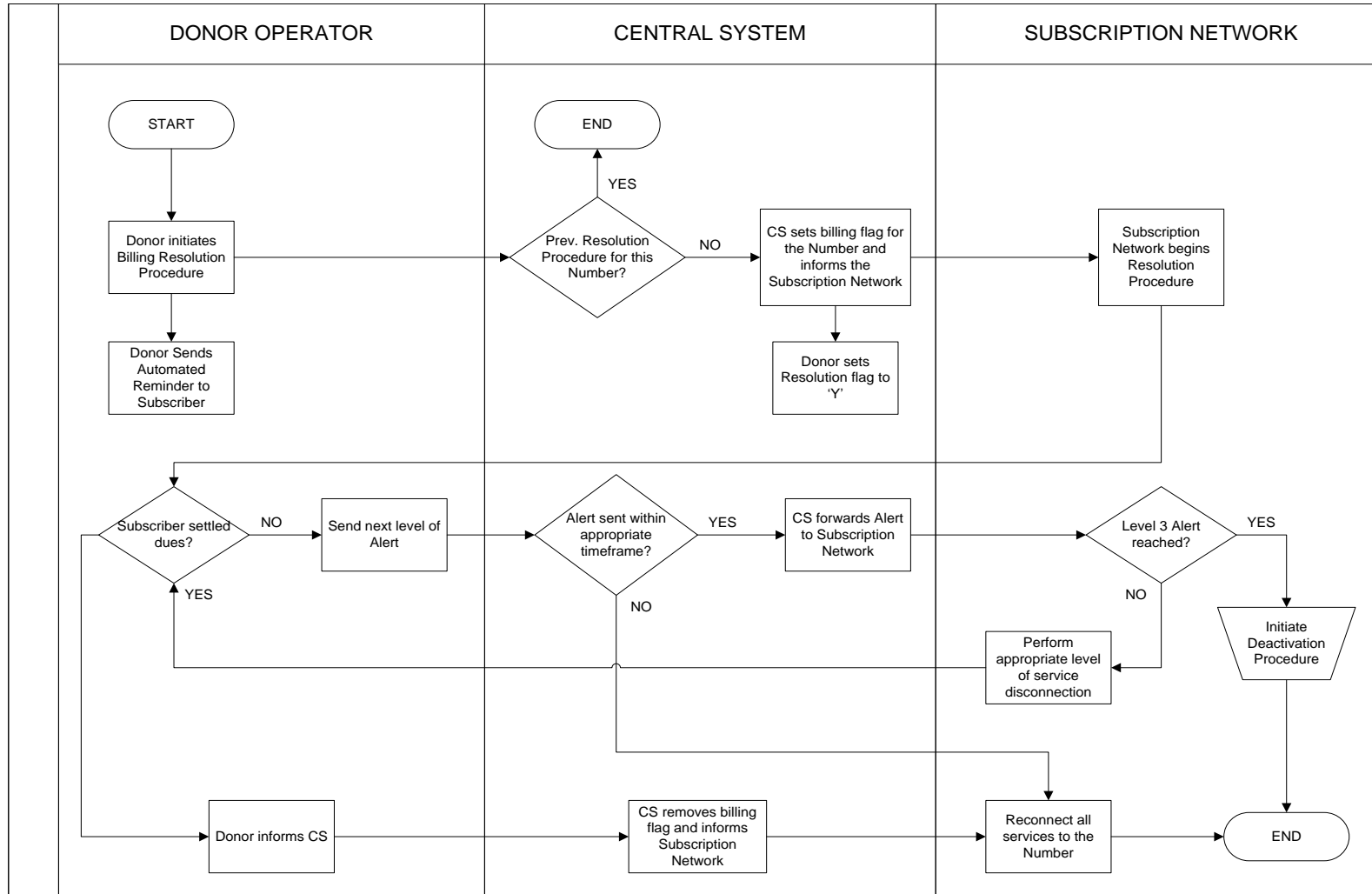

Figure 22: Billing Resolution Process Flow Diagram

6 Procedure for use of Error Code ERR0099 and Reject Code REJ0099

The originator of a Reject message or Error message needs to make sure that the sending of Reject Codes and of Error Codes is done correctly. Reject Code REJ0099 and Error Code ERR0099 should only be used in exceptional cases where none of the other defined Reject or Error Codes are applicable.

In the exceptional case that an Operator decides to use REJ0099 or ERR0099 the following procedure shall be followed:

- 1) REJ0099/ERR099 shall always be accompanied with explanatory text in the COMMENTS field in the same message.
- 2) For NpRequestReject messages that utilize Reject Code REJ0099, the Donor Operator shall contact the Recipient Operator's Number Portability Service Desk within 1 working day (8 working hours, taking into respect the Number Portability Service Desk opening hours) to discuss and agree with the Recipient Operator concerning the next steps in the Number Porting Process.
- 3) According to the normal process, a new Porting Request/message could be sent once the blocking reason has been eliminated (and triggering additional Reject or Error Codes may be prevented).
- 4) The Donor Operator shall submit a Change Request for an additional Error Code and/or Reject Code values within 10 working days to the Central System Administrator. In consultation with the parties involved in the Number Portability Process the Change Request may be granted and implemented, and the Number Portability Process Specification shall be updated accordingly. In addition, or alternatively, the (temporary) use of ERR0099 and REJ0099 may be agreed upon between the Donor Operator/originator and Recipient Operator/receiver.

7 Rules for use of Error Code ERR0029 “Unexpected or inconsistent data”

Error Code ERR0029 (“unexpected or inconsistent data”) shall be used in the following cases:

- The data in a Number Portability message is technically correct.
- The fields are populated according to the required format.
- The provided data is not in line with the expected data (e.g. the Port-ID or Porting Number does not match those in previous messages).

ERR0029 shall not be used as an answer to a NpRequest message. If a Porting Request does not pass the validation then it is answered with NpRequestReject message.

8 Complex Porting Situations

No type of Number Portability allows the Porting of multiple Numbers in a single Porting Request. Each Number to be Ported must be requested in a separate Porting Request, even if e.g.:

- 1) The Number is part of a Number Range allocated to a Subscriber who wishes to Port all or part of the Number Range;
- 2) The Number is used as a (GSM Phase 2) FAX or DATA Number for a GSM subscription;
- 3) The Number is a secondary Number (e.g. a MSN number in case of ISDN subscription) to a primary Number.

These examples will be referred in general as 'Complex Porting Cases'.

The Donor Operator will receive individual Porting Requests even in the above cases. Each Porting Request, referring to a single number, will have to be validated by the Donor Operator as to whether the Porting Request may be accepted or rejected.

It should be noted that the Regulation does not provide means to handle the Porting of Numbers in complex Porting cases in a different way than regular Number Porting cases. For this reason the Number Porting Implementation of Bahrain provides a transparent solution, and does not make a distinction between complex cases and regular cases.

In practice, complex Porting cases may require special attention from the Recipient Operator as well as from the Donor Operator and may lead to either technical or commercial issues. These issues may lead to changes in technical implementations or configurations, or in contractual and commercial assignments, before a Number (or Numbers) can be actually Ported.

The Porting Request (NpRequest) message contains a field SUBMISSION_ID. This field should be filled in by the Recipient Operator according to the format described in this Specification. This field allows the Recipient Operator to indicate that the Number to be Ported is part of a group or range of multiple Numbers to be Ported. These Numbers should all have the same SUBMISSION_ID. This will allow Licensee systems to be able to logically group two or more Porting Requests together in the Licensee's systems for ease of administration.

Numbers that are Ported singly will also be assigned a SUBMISSION_ID. However, this is of no relevance for the preparation and execution of the Porting of such a Number. The addition of the SUBMISSION_ID to such Porting Requests is intended for consistency and tracking purposes.

Prior to sending the Porting Request for a complex Porting, the Donor and Recipient Operators may need to discuss how the migration of a Subscriber and the Porting of the

Subscriber's Numbers should be prepared and executed. This may be the case, for example, for large companies using a consecutive range of Fixed Numbers that need to be partially or completely Ported.

It should be noted that complex Porting cases do not change the principles laid out in the Regulation on Number Portability that every Number is allowed to be Ported and that only a limited number of circumstances may be the reason to reject a Porting Request.

9 Number Portability Process for Universal Numbers

Universal Numbers can be used for both Fixed and Mobile services. The allocation of the service type (Fixed or Mobile) to the Universal Number determines the characteristics of the process and messages to be applied by the Recipient Operator.

For all intents and purposes, Universal Numbers defined as 'Fixed' are treated as Fixed Numbers. Therefore they cannot be cross Ported to a Mobile Licensee or for use with Mobile services. The same stipulations apply to Universal Numbers defined as 'Mobile'. TRA's Number Management System, available at www.numbering.bh, and the Number allocations published on TRA's website specify what type of service a given Universal Number block has been assigned.

10 Porting Windows/ Timers Definitions

The following timers and time windows are defined for the Number Portability Process.

Timer/Window	Description	Remarks
Porting Window	Working days: 8.00-16.00, 8 hours, from Sunday to Thursday, excluding all officially declared public holidays.	During the Porting Window the Porting Messages as defined in Chapter 4.1 will have to be processed by the receiving parties. If Porting messages are sent outside the Porting Window, the Central System will store and validate the messages, and forward them to the addressee when the Porting Window opens.
NP Service Desk open	At least during Porting Window working hours the Number Portability Service Desk must be open	The Number Portability Service Desk is an organizational entity at a Licensee that is the contact for other Licensees and for the Central System administrator in case of administrative and/or operational issues and problems related to the Number Portability Process.
Out of Service window	There may be periods (maximum 1 working day per period) agreed between an individual operator and TRA for maintenance and support purposes.	During the out of service window Licensees are allowed to stop processing Porting messages. The operator that is Out of Service should however continue receiving Porting messages and process these once the Out of Service window is closed.
Number Portability Technical Desk open	Must be available during Porting window hours at a minimum.	The Number Portability Technical Desk is an organizational entity at a Licensee that is the contact

Specification [1]: Number Portability Process Specification

Timer/Window	Description	Remarks
		for other Licensees and for the Central System administrator in case of technical issues and problems related to the Number Portability Process.
Porting Request Acknowledge time	The time that the Central System requires to respond (NpRequestAck message) to a Porting Request received from a Recipient Operator. In Section 5 this timer is referred to as T1.	5 minutes
Central System Response Time	Maximum time between Porting Request received in the Central System from Recipient Operator and sending the NpRequestReject message by the Central System. In Section 5 this timer is referred to as T2.	15 minutes
Donor Operator Response Time	Time between the Porting Request (from the Central System to Donor Operator) and the NpRequestAccept or NpRequestReject by Donor Operator (received by the Central System). In Section 5 this timer is referred to as T3.	Maximum 1 working day (8 working hours)
Porting Request Response Time	Maximum time between the submission of the NpRequest by the Recipient Operator (received by the	T1+T3

Specification [1]: Number Portability Process Specification

Timer/Window	Description	Remarks
	<p>Central System) and NpRequestAccept or NpRequestReject by the Donor Operator (sent from the Central System to Recipient Operator).</p> <p>In Section 5 this timer is referred to as T4.</p>	
<p>Standard Porting time (End to End)</p>	<p>Time between submissions of the NpRequest by the Recipient Operator (received by the Central System) until sending the NpExecuteComplete message is sent from the Central System to the Recipient Operator.</p> <p>In Section 5 this timer is referred to as T11.</p>	<p>Maximum 1 working day (8 working hours) for Donor Operator acceptance plus maximum 2 working days (16 working hours) for porting execution.</p>
<p>Porting Execution Time</p>	<p>Time required for the Donor Operator to disconnect a Number and to update routing tables. The time is measured as the time elapsed between sending the NpExecuteBroadcast message (By the Central System to Donor Operator) and the receiving of the NpExecuteComplete (by the Central System from Donor Operator).</p> <p>In Section 5 this timer is referred to as T5a.</p>	<p>10 Minutes</p>
<p>Porting Broadcast Time</p>	<p>Time required for other Licensees to update their</p>	<p>15 Minutes</p>

Specification [1]: Number Portability Process Specification

Timer/Window	Description	Remarks
	<p>routing tables. The time is measured as the time elapsed between sending the NpExecuteBroadcast message (By the Central System to Other Operator) and the receiving of the NpExecuteComplete message (by the Central System from Other Operator).</p> <p>In Section 5 this timer is referred to as T5b.</p>	
<p>Porting Execution Time: end to end from Recipient Operator point of view</p>	<p>Time between the Recipient Operator sending (and the Central System receiving) a NpExecute message and the Recipient Operator receiving (the Central System sending) a NpExecuteComplete message.</p> <p>In Section 5 this timer is referred to as T6.</p>	<p>T5a + processing time of the Central System.</p> <p>Processing time should not exceed 5 minutes</p>
<p>Deactivation Acknowledge time</p>	<p>The time that the Central System requires to respond (NpDeactivateAck message) to a NpDeactivate message received from a Licensee.</p> <p>In Section 5 this timer is referred to as T7.</p>	<p>5 Minutes</p>
<p>Deactivation Time</p>	<p>Time required for the Block Operator to respond to the Deactivation process.</p> <p>The time is measured as the time elapsed between sending the NpDeactivateBroadcast message (by the Central System to Block Operator)</p>	<p>30 Minutes</p>

Specification [1]: Number Portability Process Specification

Timer/Window	Description	Remarks
	<p>and receiving of the NpDeactivateComplete message (by the Central System from the Block Operator).</p> <p>In Section 5 this timer is referred to as T8a.</p>	
Deactivation Broadcast Time	<p>Time required for Other Operators to respond to the Deactivation process.</p> <p>The time is measured as the time elapsed between sending the NpDeactivateBroadcast message (by the Central System to Other Operator) and the receiving of the NpDeactivateComplete message (by the Central System from Other Operator).</p> <p>In Section 5 this timer is referred to as T8b.</p>	30 Minutes
Return Period	<p>Time allowed to return a Number to the Number Range holder (Block Operator) after a previously Ported Number has been disconnected.</p>	30 calendar days at maximum
NP Query Time	<p>Time between the Licensee sending a NpQuery message and the Central System responding with a NpQueryComplete message.</p> <p>In Section 5 this timer is referred to as T10.</p>	NP Query Time will depend on the amount of data that is requested.

Specification [1]: Number Portability Process Specification

Timer/Window	Description	Remarks
Billing Notification Period	<p>The period of time within which the Donor Operator may initiate a Billing Resolution Process by sending a NpBillingResolution message to the Subscription Network.</p> <p>In Section 5 this timer is referred to as T12.</p>	No earlier than 2 Calendar weeks after the Porting Date and no later than 3 three Calendar months after the Porting Date.
Minimum Billing Resolution Alert Time	<p>The minimum time between service degradation levels during the Billing Resolution Process. After the Minimum Billing Resolution Alert Time expires the Donor Operator may send a Billing Resolution Alert Message, to force the Recipient Operator to apply the next level of service degradation to the Subscriber's Ported Number.</p> <p>In Section 5 this timer is referred to as T13</p>	1 Calendar Week
Maximum Billing Resolution Alert Time	<p>The maximum time between service degradation levels during the Billing Resolution Process. The next sequential Billing Resolution Alert Message should have been received before the Maximum Billing Resolution Alert Time expires. If the Maximum Billing Resolution Alert Time expires, the Billing Resolution Process is terminated and the subscription and services using the Ported Number are returned to normal status.</p>	2 Calendar Weeks

Specification [1]: Number Portability Process Specification

Timer/Window	Description	Remarks
	In Section 5 this timer is referred to as T14.	

11 Key Performance Indicators (KPI)

The following Key performance Indicators are defined for the Number Portability Process:

Name of Timer	Timer value	KPI
Porting Request Acknowledge time (T1)	5 minutes	At least 98% of Porting Acknowledgements should be sent by the Central System to the Recipient Operator within 5 minutes.
The Central System check on blocking issues (T2)	15 minutes	At least 98% of Porting REJECTs should be sent by the Central System to the Recipient Operator within 15 minutes.
Donor Operator check on blocking issues (T3, T4)	8 working hours	At least 98% of Porting Requests received by the Donor Operator must be responded to within 8 working hours.
Standard Porting time (T11)	Maximum 16+8 working hours	At least 98% of Number Ports requested should have been executed at the planned date of execution.
Porting Execution Time (T6)	10 Minutes	At least 95% of Porting execution cases by the Donor Operator must be completed within 10 minutes.
Porting Broadcast Time (T5a/b)	15 Minutes	At least 95% of Porting broadcast execution cases by other operators must be completed within 15 minutes.
Deactivation Acknowledge time (T7)	5 minutes	At least 98% of Deactivation Acknowledgements should be sent by the Central System to the Recipient Operator within 5 minutes
Deactivation Time (T8a)	30 Minutes	At least 95% of Deactivation cases by the Block Operator must be completed within 30

Specification [1]: Number Portability Process Specification

Name of Timer	Timer value	KPI
		minutes.
Deactivation Broadcast Time (T8b)	30 Minutes	At least 95% of Deactivation broadcast cases by other operators must be completed within 30 minutes.

Glossary

ACQ	All Call Query, a routing method for Number Portability.
Back port	A Porting where the Number Ports back to the Block Operator/ original Number holder.
Bad Debt	'Bad Debt' is defined as 'unpaid fees, bills or other dues that have been invoiced and notified to a Subscriber, in direct relation to a Number that has been Ported out, which have passed the due date and are equal to or over BHD 3 in value. By this definition, unpaid fees which have not been invoiced or contractual payments which are not yet due (such as installment plans) do not constitute Bad Debt status, nor do any dues that were not communicated or notified to the Subscriber. Bad Debt is one of the possible reasons to reject a Porting Request. If the Subscriber that wishes to Port a Number has been issued an invoice for which the stated due date has passed (and a notification of that status has been issued to the Subscriber by SMS, by email, by postal delivery or by automatic call announcement), and the minimum amount of debt value (BD 3) is exceeded then the Donor Operator can reject the Porting Request for reasons of 'Bad Debt'.
Billing Notification Period	After the completion of a Number Porting (Recipient Operator having received Porting Executed message), if (bad) debt exists within the Billing Notification period then the Donor Operator may start the Billing Resolution Process.
Billing Resolution Process	A process which aids the Donor Operator in recovering outstanding Bad Debt from a previously Ported Subscriber. The Billing Resolutions process may result in the clearance of Bad Debt and the resumption of normal service to the Number; the disconnection of the Number; or a 'time-out' of the process which leads to the resumption of normal service to the Number.
Block Operator	The Licensee who is the original holder of a Ported Number-as it has been assigned the range.
Central System	The system for Number Portability in the Kingdom of Bahrain is referred to as the Central System. The Central System acts as the clearing House for message validation and message handling and routing, provides the communications channels for Licensees and other parties and holds the Ported Number Database.
Deactivation process	This process concerns the return of a Number to the Block Operator holding the Number Range to which the previously Ported Number belongs to. This return will take place within a maximum period of 30 days (Return Period) after the Subscription Network has disconnected a Number which has been previously Ported to the Subscription Network. The Ported Number must be returned to the Block Operator if the Subscriber has been disconnected for any reason other than onward Porting. Only the Block Operator is entitled to re-use the Number for a new subscription.
Destination	(In the context of call routing) The Licensee which is receiving a call.

Specification [1]: Number Portability Process Specification

Network	
Donor Operator	The Licensee who is transferring the Number to the Recipient Operator.
Execution	This process concerns the actual execution of the Number Porting between a Recipient Operator and a Donor Operator of the agreed Number within the defined timeframe.
FNP	Fixed Number Portability
FTA	Fixed Terminating Access fee, In Kingdom of Bahrain referred to as 'PSTN Terminating Access'
HLR	Home Location Register
IAM	Initial Address Message (ISUP)
IMSI	International Mobile Subscriber Identity. Number used for identification of a mobile subscriber. It is stored on the SIM card and sent by the phone to the network.
IOT	Inter Operator Tariff
ISUP	ISDN User Part or ISUP is part of the Signaling System #7 which is used to set up telephone calls in Public Switched Telephone Networks.
Maximum Resolution Alert Time	The maximum time between service degradation levels during the Billing resolution process is called the Maximum Billing Resolution Alert time. The Billing Resolution Alert Message should have been received before the Maximum Billing Resolution Alert Time expires. If the Maximum Billing Resolution Alert Time expires, the Billing Resolution Process is terminated and the subscription (using the Ported Number) returns to normal status.
MCC MNC	Mobile Country Code & Mobile Network Code, also 5 (in USA 6) digits of IMSI
Minimum Billing Resolution Alert Time	The minimum time between service degradation levels during the Billing resolution process is called the Minimum Billing Resolution Alert Time. After the Minimum Billing Resolution Alert Time expires the Donor Operator may send a Billing Resolution Alert Message, to force the Recipient Operator to a next level of degradation.
MNP	Mobile Number Portability
Number Portability Messages	Messages exchanged via the Central System during the Porting Process: between Recipient Operator and Donor Operator and Other Operator
MSISDN	Mobile Subscriber Integrated Services Digital Network Number
NP	Number Portability: the capability for a Subscriber to change Licensee without

	changing their Number
Number Portability Phase	The Number Porting Process consists of five procedures, not all of which are invoked sequentially: <ol style="list-style-type: none"> 1. Preparation 2. Execution 3. Deactivation 4. Query 5. Billing Notification
NSN	National Significant Number, in Bahrain this is in the format ABCDEFGH
OR	Onward Routing
OLO	Other Licensed Operator
Other Operator	Other operator or other participants in the Porting Process: other mobile operators and fixed (transit) operators which are informed about the Porting of Numbers or deactivation of previously Ported Numbers via broadcast messages
Operator Code	A code used in Number Portability messages to identify a participant (example: ZAIN or the Central System). Used in fields like DONOR_ID, RECIPIENT_ID, ORIGINATION_ID.
Originating Network	(In the context of call routing) The Licensed Operator originating a call
Preparation process	This process concerns the information exchange between a Recipient Operator and a Donor Operator in order to accept or reject the Number Porting Request of a Subscriber.
Port-ID	Unique ID assigned by the Central System. To be used in messages referring to a specific Porting instance. It is constructed by a 4 digit Recipient Operator code-4 digit Donor Operator code- date of sending the Porting Request YYYYMMDD- 5 digit sequence number restarted each day. The combination of Date and Sequence Number is unique. Example: ZAIN-BTCM-20100907-00001
Ported Number	The Number that a subscriber wishes to keep when changing from one Licensee to another. The Number shall be transferred from the Donor Operator to the Recipient Operator during the Porting process.
Query process	This process concerns the query to the Central System for some or all Numbers. The query may concern individual Numbers, ranges of Numbers, a certain time span or a specific Operator's Numbers that are Ported. This message is not to be confused with real-time Number Portability lookups performed for call processing within each Licensee's network.
Recipient	The Licensee to whom the Number is being Ported.

Operator	
Routing Number (RN)	A number (example a01) which is used to route voice calls or signaling (such as SMS) to the correct Subscription Network. This number is used in the Porting Broadcast messages, which allows participants to update their routing tables accordingly (also known as 'pointers').
Service Provider	A Service Provider is a reseller, using the equipments (such as SIM cards), and Numbers of a Licensee under its own brand. The Licensee will have to take responsibility for the Porting Process as it is responsible towards TRA to meet the terms of the Regulation and is liable in case the reseller violates the Regulation.
Subscription Network	The currently serving Network for a given Number. Once a Number has been Ported to the Recipient Operator, then the Recipient Operator is further referred to as the Subscription Network.
SUBMISSION_ID	The SUBMISSION_ID is an identifier that the Recipient Operator adds to the Porting Request. Based on the SUBMISSION_ID the Donor Operator is able to identify Numbers which have been submitted as part of a single batch for a single Subscriber.
Transit Network	Licensee carrying traffic between the Originating Network and Destination Network
Universal Number	A Number that may be defined as either a Fixed or Mobile Number by the Block Operator to whom Number Range has been allocated. Once defined as either Fixed or Mobile, the Number is no longer considered to be Universal and follows all the relevant processes, rules and restrictions of its type.